

Medium Duty Hydraulic Cylinders

Series 3L



Medium Duty Service Industrial Tie Rod Construction

- Nominal Pressure – 1000 PSI –
Depending on Bore Size
- Standard Bore Sizes
1" through 8"
- Piston Rod Diameters –
1/2" through 5-1/2"
- 17 Standard Mounting Styles

For Cylinder Division Plant Locations – See Page II.

The medium-duty hydraulic cylinder with a proven record of performance.

Parker Series 3L cylinders have established an impressive record of millions of *continuous* maintenance-free cycles. Each one is built with important extras you wouldn't ordinarily find in cylinders designed for 1,000 psi nominal operating pressure. Patented "Jewel" rod gland for longer life and lower operating costs. High

yield-strength and rolled threads add extra strength to rod end studs. High strength tie rods also with rolled threads instead of just cut. And every Parker cylinder is *individually* tested before it is shipped. Parker puts more into the Series 3L so you get more out.



For additional information – call your local Parker Cylinder Distributor.

Series 3L Medium Duty Hydraulic Cylinders

Specifications/ Mountings

Standard Specifications

- Medium Duty Service – ANSI/NFPA T3.6.7R2 - 1996 Specifications and Mounting Dimension Standards
- Standard Construction – Square Head – Tie Rod Design
- Nominal Pressure – 1000 PSI Dependent on Bore Size*
- Standard Fluid – Hydraulic Oil
- Standard Temperature -10°F to +165°F**
- Bore Sizes – 1" through 8"

In line with our policy of continuing product improvement, specifications in this catalog are subject to change.

Note: Series 3L Hydraulic Cylinders fully meet ANSI/NFPA T3.6.7R2 - 1996 Specifications and Mounting Dimensions for Square Head Industrial Fluid Power Cylinders.

†Parker Style JJ mount for the Series 3L is a non-NFPA mount.

- Piston Rod Diameter – 1/2" through 5 1/2"
- Mounting Styles – 16 standard styles at various application ratings
- Strokes – Available in any practical stroke length
- Cushions – Optional at either end or both ends of stroke. Float Check at cap end.
- Rod Ends – Three Standard Choices – Specials to Order

* See Section C, page 84 for recommended operating pressure.

** See Section C, Page 83 for higher temperature service.

Available Mounting Styles

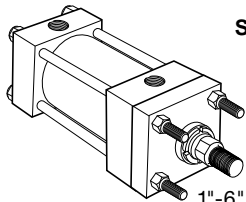
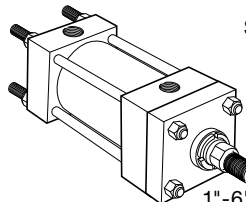
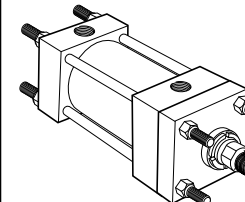
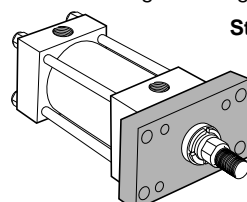
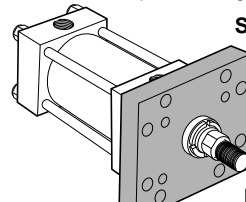
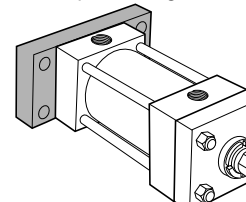
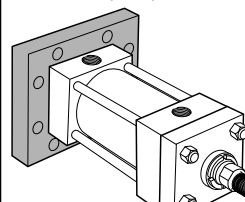
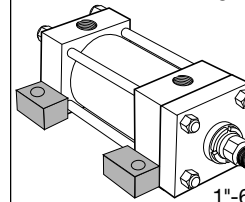
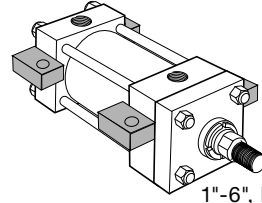
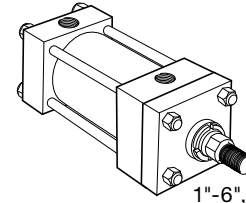
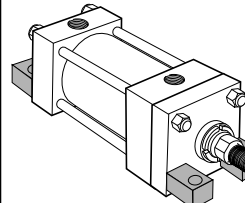
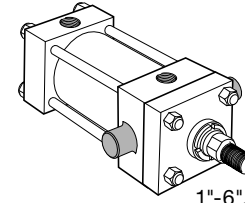
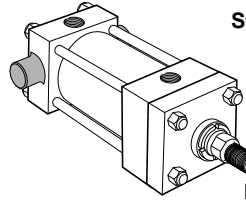
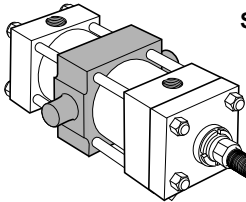
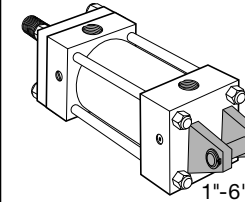
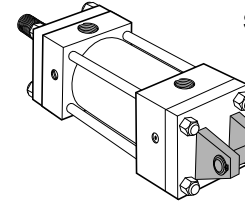
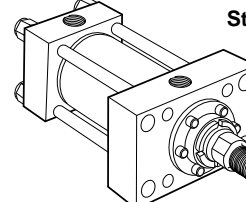
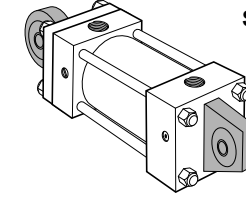
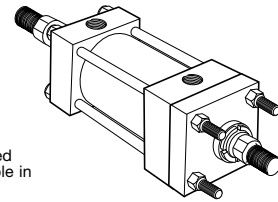
<p>Tie Rods Extended Head End</p>  <p>Style TB</p> <p>1"-6", Page 8 8", Page 22</p> <p>(NFPA MX3)</p>	<p>Tie Rods Extended Cap End</p>  <p>Style TC</p> <p>1"-6", Page 8 8", Page 22</p> <p>(NFPA MX2)</p>	<p>Tie Rods Extended Both Ends</p>  <p>Style TD</p> <p>1"-6", Page 8 8", Page 22</p> <p>(NFPA MX1)</p>	<p>Head Rectangular Flange</p>  <p>Style J</p> <p>1"-6", Page 8</p> <p>(NFPA MF1)</p>
<p>Head Square Flange</p>  <p>Style JB</p> <p>1"-6", Page 10 8", Page 22</p> <p>(NFPA MF5)</p>	<p>Cap Rectangular Flange</p>  <p>Style H</p> <p>1"-6", Page 8</p> <p>(NFPA MF2)</p>	<p>Cap Square Flange</p>  <p>Style HB</p> <p>1"-6", Page 10 8", Page 22</p> <p>(NFPA MF6)</p>	<p>Side Lug</p>  <p>Style C</p> <p>1"-6", Page 12 8", Page 24</p> <p>(NFPA MS2)</p>
<p>Centerline Lugs</p>  <p>Style E</p> <p>1"-6", Page 12 8", Page 24</p> <p>(NFPA MS3)</p>	<p>Side Tapped</p>  <p>Style F</p> <p>1"-6", Page 14 8", Page 24</p> <p>(NFPA MS4)</p>	<p>Side End Lugs</p>  <p>Style G</p> <p>1 1/2"-6", Page 14 8", Page 26</p> <p>(NFPA MS7)</p>	<p>Head Trunnion</p>  <p>Style D</p> <p>1"-6", Page 16 8", Page 28</p> <p>(NFPA MT1)</p>
<p>Cap Trunnion</p>  <p>Style DB</p> <p>1"-6", Page 16 8", Page 28</p> <p>(NFPA MT2)</p>	<p>Intermediate Fixed Trunnion</p>  <p>Style DD</p> <p>1 1/2"-6", Page 16 8", Page 28</p> <p>(NFPA MT4)</p>	<p>Cap Fixed Clevis</p>  <p>Style BB</p> <p>1"-6", Page 18 8", Page 26</p> <p>(NFPA MP1)</p>	<p>Cap Detachable Clevis</p>  <p>Style BC</p> <p>1"-6", Page 18</p> <p>(NFPA MP2)</p>
<p>Head Rectangular</p>  <p>Style JJ†</p> <p>1"-6", Page 20</p>	<p>Spherical Bearing</p>  <p>Style SB</p> <p>See Pages 30 and 31.</p>	<p>Double Rod Cylinders</p>  <p>Style KTB Shown</p> <p>Most of the above illustrated mounting styles are available in double rod cylinders. See Catalog Page 32.</p>	

For Cylinder Division Plant Locations – See Page II.

The inside story on why Series 3L is your best choice in medium duty hydraulic cylinders

Secondary Seal – Double-Service Wiperseal® (Hannifin Patent #2907596) – wipes clean any oil film adhering to the rod on the extend stroke and cleans the rod on the return stroke.

Piston Rod Stud – Furnished on 2" diameter rods and smaller when standard style #4 rod end threads are required or on 1 3/8" diameter rods and smaller when style #8 threads are required. Also available in 2 times the catalog "A" dimension length. Studs have rolled threads and are made from high strength steel. Anaerobic adhesive is used to permanently lock the stud to the piston rod.

"Jewel" Rod Gland Assembly – Externally removable without cylinder disassembly. Long bearing surface is inboard of the seals, assuring positive lubrication from within the cylinder. An "O" ring is used as a seal between gland and head, and also serves as a prevailing torque-type lock.

Primary Seal – New TS-2000 Rod Seal is a proven leakproof design – completely self-compensating and self-relieving to withstand variations and conform to mechanical deflection that may occur.

Optional Adjustable Floating Stepped Cushions

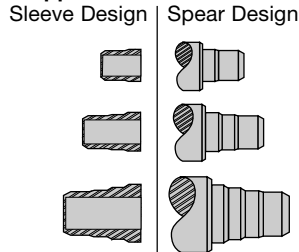

High Strength Tie Rods – Made from 100,000 psi minimum yield steel with rolled threads for added strength.

Adjustable Floating Cushions – Optional at extra charge. For faster cycle time and increased productivity – for maximum performance – economical and flexible for even the most demanding applications – reduces shock and machine noise – lower maintenance costs – can be supplied at head, cap or both ends.

Steel Head – Bored and grooved to provide concentricity for mating parts.

Ports – NPTF ports are standard.

End Seals – Pressure-actuated cylinder body-to-head and cap "O" rings.

The Cylinder Body – Heavy-wall steel tubing, honed to a micro finish bore.

Adjustable floating cushions

Cushions are optional and can be supplied at head end, cap end, or both ends without change in envelope or mounting dimensions. All Parker cushions are adjustable. The Series 3L cylinder design incorporates the longest cushion sleeve and cushion spear that can be provided in the standard envelope without decreasing the rod bearing and piston bearing lengths.

- (1) When a cushion is specified at the head end:
 - a. A self-centering sleeve is furnished on the piston rod assembly.
 - b. A needle valve is provided that is flush with the side of the head when wide open. It may be identified by the fact that it is socket keyed. It is located on side number 2, in all mounting styles except D, DB, DD, and E. In these styles it is located on side number 3.
 - c. On 3 1/4" bores and larger, a springless check valve is provided that is also flush with the side of the

head and is mounted adjacent to the needle valve except on certain bores of mounting style C where it is mounted opposite the needle valve. It may be identified by the fact that it is slotted.

- d. The check and needle valves are interchangeable in the head.
 - e. 1" - 2 1/2" bore 3L's utilize a slotted sleeve design in place of the check valve.
- (2) When a cushion is specified at the cap end:
 - a. A cushion spear is provided on the piston rod assembly.
 - b. A "float check" self-centering bushing is provided which incorporates a large flow check valve for fast "out-stroke" action.
 - c. A socket-keyed needle valve is provided that is flush with the side of the cap when wide open. It is located on side number 2 in all mounting styles except D, DB, DD, and E. In these styles it is located on side number 3.

For additional information – call your local Parker Cylinder Distributor.

Piston Rod – Medium carbon steel, induction case-hardened to 54 Rc, hard chrome-plated and polished to 10 RMS finish. Piston rods are made from 90,000 to 100,000 psi minimum yield material in 1/2" through 4" diameters. Larger diameters vary between 57,000 and 90,000 psi minimum material, depending on rod diameter. The piston thread equals the catalog style #4 rod end thread for each rod diameter to assure proper piston-to-rod thread strength. Two wrench flats are provided for rod end attachment.

Ports – NPTF ports are standard.

Steel Cap – Bored and grooved to provide concentricity for mating parts.

Optional Ports

Ports – SAE "O" ring ports are optional at no extra charge. Oversize NPTF and SAE ports are available at extra charge.

Seals – Buna-N (Nitrile) seals are standard.

Fluorocarbon Seals – Optional at extra charge.

Alloy Steel Tie Rod Nuts

Align-A-Groove – (Patent #3043639) – A 3/16" wide surface machined at each end of the cylinder body. Makes precise mounting quick and easy.

One-Piece Nodular Iron Piston – The wide piston surface contacting cylinder bore reduces bearing loads. Anaerobic adhesive is used to permanently lock and seal the piston to the rod.

Step Cut Iron Piston Rings are standard.

The exclusive "Jewel" gland gives you longer cylinder life, better performance and lower costs.



An extra-long inboard bearing surface insures lubrication from within the cylinder. Outboard of the bearing surface are two leakproof seals – The TS-2000 and Wiperseal. The serrated TS-2000 (primary seal) is completely self-compensating and self-relieving. It adjusts to mechanical deflections or any pressure variation from near-zero to rated operating pressure. The result is positive, no-leak sealing – regardless of conditions.

The Wiperseal does double duty. On the advance stroke, it acts as a secondary pressure seal. On the return, it wipes away any dirt on the rod. This means less wear on bearing surfaces and internal parts. Longer life for working parts. And, less loss of fluid. Plus, you can replace a "Jewel" gland without removing the tie rods or the retainer. Just a few twists with a spanner wrench does the job.

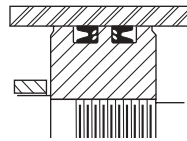

Optional Lipseal® Piston

Optional at no extra charge. Zero leakage under static conditions. Seals are self-compensating to conform to variations in pressure, mechanical deflection, and wear. Back-up washers prevent extrusion.

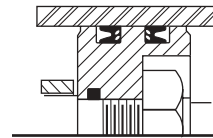

Optional Nut Retained Piston

Piston with retainer nut optional at extra charge.

Cushion Length

Cylinder Bore (Inches)	Rod Diameter* (Inches)	Rod Number	Cushion Length (Inches)	
			Head*	Cap
1	1/2	1	7/8	3/4
	5/8	2	7/8	3/4
1 1/2	5/8	1	7/8	13/16
	1	2	7/8	13/16
2	5/8	1	7/8	13/16
	1 3/8	2	7/8	13/16
2 1/2	1	1	7/8	13/16
	1 3/4	2	7/8	13/16
3 1/4	1	1	1 1/8	1
	2	2	13/16	1
4	1 3/8	1	1 1/8	1
	2 1/2	2	13/16	1

Cylinder Bore (Inches)	Rod Diameter* (Inches)	Rod Number	Cushion Length (Inches)	
			Head*	Cap
5	1 3/4	1	1 1/8	1
	3 1/2	2	13/16	1
6	1 3/4	1	13/8	1 1/4
	4	2	1 1/16	1 1/4
8	2	1	1 1/16	1 1/4
	5 1/2	2	15/16	1 1/4

* Head end cushions for rod diameters not listed have cushion lengths within the limits shown.

For Cylinder Division Plant Locations – See Page II.



Tie Rod and Rectangular Flange Mountings
1" to 6" Bore Sizes

Series 3L
Medium Duty Hydraulic Cylinders

Tie Rods Extended
Style TB
(NFFA Style MX3)

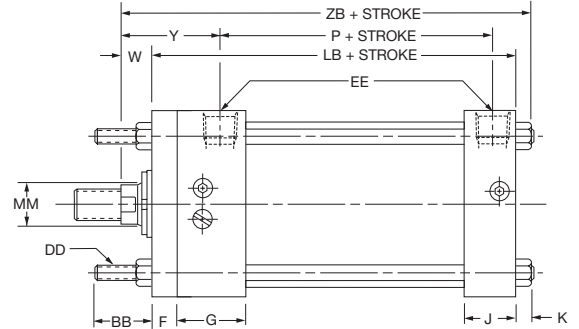
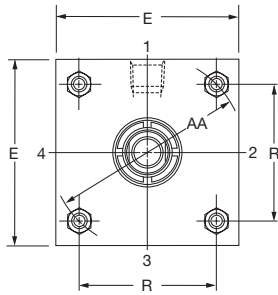
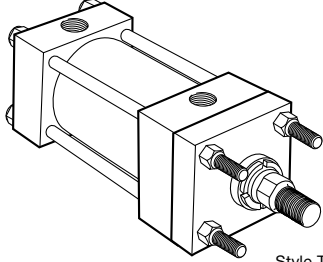

Style TB (NFFA MX3) Head Tie Rods Extended, illustrated: Style TC (NFFA MX2), Cap Tie Rods Extended; and Style TD (NFFA MX1), Both Ends Tie Rods Extended are also available. All "T" styles can be dimensioned from Style TB drawing at right.
Basic Mounting (T) — NFFA MX0 — no tie rods extended can be supplied upon request.

Head Rectangular Flange
Style J
(NFFA Style MF1)

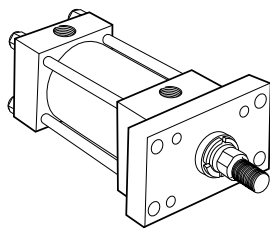

For Style "J" Mount

Bore Size	Max. PSI — Push*			
	1,7,8	2	3,4	5,6
1	650	450	—	—
1½	650	375	—	—
2	500	200	350	—
2½	300	150	200	—
3¼	650	350	400	—
4	450	225	325	—
5	300	125	225	175
6	350	200	300	200

*Maximum pressure rating — push application.

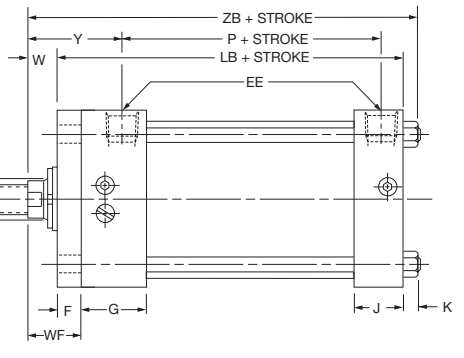
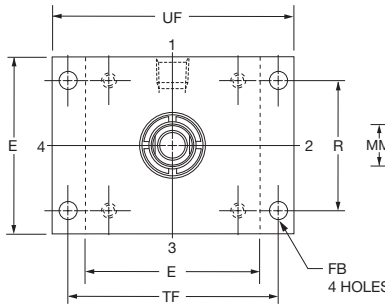

Cap Rectangular Flange
Style H
(NFFA Style MF2)

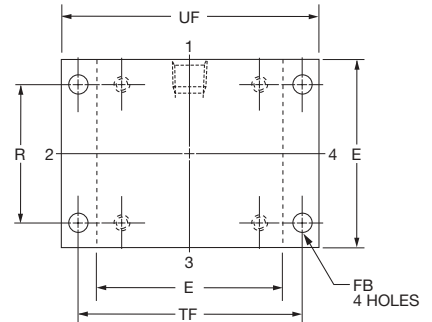
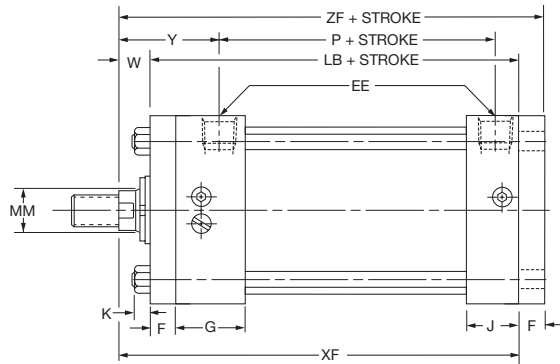
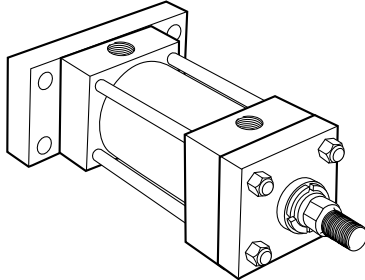

Rod End Dimensions—see table 2

Thread Style 4
(NFFA Style SM)
Small Male

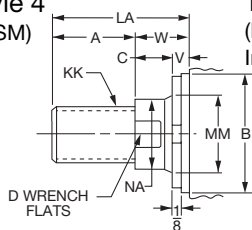

Thread Style 8
(NFFA Style IM)
Intermediate Male

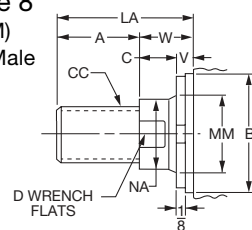

Thread Style 9
(NFFA Style SF)
Small Female

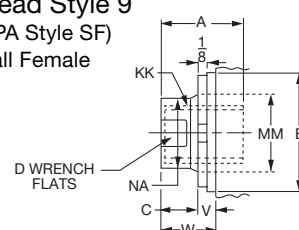

Straight Thread Port Adapters

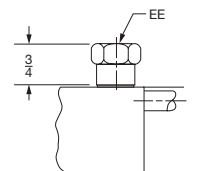

A high strength rod end stud is supplied on thread style 4 through 2" diameter rods and on thread style 8 through 1½" diameter rods. Larger sizes or special rod ends are cut threads. Style 4 rod ends are recommended where the workpiece is secured against the rod shoulder. When the workpiece is

not shouldered, style 4 rod ends are recommended through 2" piston rod diameters and style 8 rod ends are recommended on larger diameters. Use style 9 for applications where female rod end threads are required. If rod end is not specified, style 4 will be supplied.

Used on 1½" bore cap end. Also used on 1½" bore with Code 2 rod head end.

"Specials" Thread Style 3

To order, specify "Style 3" and give desired dimensions for CC or KK, A and LA. If otherwise special, furnish dimensional sketch.

For additional information — call your local Parker Cylinder Distributor.

Series 3L Medium Duty Hydraulic Cylinders

Tie Rod and Rectangular Flange Mountings 1" to 6" Bore Sizes

Table 1—Envelope and Mounting Dimensions

Bore	AA	BB	DD	E	EE		F	FB	G	J	K	R	TF	UF	Add Stroke	
					NPTF [†]	SAE*									LB	P
1 [‡]	1.53	3/4	10-24	■	1/4 [†]	6 [#]	3/8	1/4	11/2	1	3/16	1.08	2	2 1/2	37/8	2 1/8
1 1/2	2.02	1	1/4-28	2	3/8 [†]	6 [#]	3/8	5/16	11/2	1	1/4	1.43	2 3/4	3 3/8	4	2 1/4
2	2.6	1 1/8	5/16-24	2 1/2	3/8 [†]	6	3/8	3/8	11/2	1	5/16	1.84	3 3/8	4 1/8	4	2 1/4
2 1/2	3.1	1 1/8	5/16-24	3	3/8 [†]	6	3/8	3/8	11/2	1	5/16	2.19	3 7/8	4 5/8	4 1/8	2 3/8
3 1/4	3.9	1 3/8	3/8-24	3 3/4	1/2	10	5/8	7/16	13/4	1 1/4	3/8	2.76	4 11/16	5 1/2	4 7/8	2 5/8
4	4.7	1 3/8	3/8-24	4 1/2	1/2	10	5/8	7/16	13/4	1 1/4	3/8	3.32	5 7/16	6 1/4	4 7/8	2 5/8
5	5.8	1 13/16	1/2-20	5 1/2	1/2	10	5/8	9/16	13/4	1 1/4	7/16	4.10	6 5/8	7 5/8	5 1/8	2 7/8
6	6.9	1 13/16	1/2-20	6 1/2	3/4	12	3/4	9/16	2	1 1/2	7/16	4.88	7 5/8	8 5/8	5 3/4	3 1/8

○ NPTF ports will be furnished as standard unless SAE straight thread ports are specified.

* SAE straight thread ports are indicated by port number.

‡ Cushion adjusting needle valve for 1" bore projects beyond sides of head and cap.

† On 1", 1 1/2", 2" and 2 1/2" bore sizes, the head end (only) pipe thread is not full depth on cylinders with No. 2 rods. Minimum of 3 full threads available.

■ 1" bore 3L heads are rectangular — see page 20.

Straight thread ports on 1 1/2" bore cap end, and head end with Code 2 rod, require an adapter fitting. (See "Straight Thread Port Adapter" drawing on opposite page.) Adapters are furnished as standard.

Table 2—Rod Dimensions

Bore	Rod No.	Rod Dia. MM	Thread		Rod Extensions and Pilot Dimensions								Add Stroke				
			Style 8 CC	Style 4 & 9 KK	A	+0.000 -0.002 B	C	D	LA	NA	V	W	WF	Y	XF	ZB	ZF
1	1(Std.)	1/2	7/16-20	5/16-24	5/8	.999	3/8	3/8	11/4	7/16	1/4	5/8	1	115/16	4 1/2	4 11/16	4 7/8
	2	5/8	1/2-20	7/16-20	3/4	1.124	3/8	1/2	13/8	9/16	1/4	5/8	1	115/16	4 1/2	4 11/16	4 7/8
1 1/2	1(Std.)	5/8	1/2-20	7/16-20	3/4	1.124	3/8	1/2	13/8	9/16	1/4	5/8	1	115/16	4 5/8	4 7/8	5
	2	1	7/8-14	3/4-16	1 1/8	1.499	1/2	7/8	2 1/8	15/16	1/2	1	1 3/8	25/16	5	5 1/4	5 3/8
2	1(Std.)	5/8	1/2-20	7/16-20	3/4	1.124	3/8	1/2	13/8	9/16	1/4	5/8	1	115/16	4 5/8	4 15/16	5
	2	1 3/8	1 1/4-12	1-14	1 5/8	1.999	5/8	1 1/8	2 7/8	15/16	5/8	1 1/4	1 5/8	29/16	5 1/4	5 9/16	5 5/8
	3	1	7/8-14	3/4-16	1 1/8	1.499	1/2	7/8	2 1/8	15/16	1/2	1	1 3/8	25/16	5	5 5/16	5 3/8
2 1/2	1(Std.)	1	7/8-14	3/4-16	1 1/8	1.499	1/2	7/8	2 1/8	15/16	1/2	1	1 3/8	25/16	5 1/8	5 1/16	5 1/2
	2	1 3/4	1 1/2-12	1 1/4-12	2	2.374	3/4	1 1/2	3 1/2	1 11/16	3/4	1 1/2	1 7/8	2 13/16	5 5/8	5 5/16	6
	3	1 3/8	1 1/4-12	1-14	1 5/8	1.999	5/8	1 1/8	2 7/8	15/16	5/8	1 1/4	1 5/8	29/16	5 3/8	5 11/16	5 3/4
	7	5/8	1/2-20	7/16-20	3/4	1.124	3/8	1/2	13/8	9/16	1/4	5/8	1	115/16	4 3/4	5 1/16	5 1/8
3 1/4	1(Std.)	1	7/8-14	3/4-16	1 1/8	1.499	1/2	7/8	1 7/8	15/16	1/4	3/4	1 3/8	2 7/16	5 5/8	6	6 1/4
	2	2	1 3/4-12	1 1/2-12	2 1/4	2.624	7/8	1 11/16	3 5/8	1 15/16	1/2	1 3/8	2	3 1/16	6 1/4	6 5/8	6 7/8
	3	1 3/8	1 1/4-12	1-14	1 5/8	1.999	5/8	1 1/8	2 5/8	15/16	3/8	1	1 5/8	2 11/16	5 7/8	6 1/4	6 1/2
	4	1 3/4	1 1/2-12	1 1/4-12	2	2.374	3/4	1 1/2	3 1/4	1 11/16	1/2	1 1/4	1 7/8	2 15/16	6 1/8	6 1/2	6 3/4
4	1(Std.)	1 3/8	1 1/4-12	1-14	1 5/8	1.999	5/8	1 1/8	2 5/8	15/16	3/8	1	1 5/8	2 11/16	5 7/8	6 1/4	6 1/2
	2	2 1/2	2 1/4-12	1 7/8-12	3	3.124	1	2 1/16	4 5/8	2 3/8	5/8	1 5/8	2 1/4	3 5/16	6 1/2	6 7/8	7 1/8
	3	1 3/4	1 1/2-12	1 1/4-12	2	2.374	3/4	1 1/2	3 1/4	1 11/16	1/2	1 1/4	1 7/8	2 15/16	6 1/8	6 1/2	6 3/4
	4	2	1 3/4-12	1 1/2-12	2 1/4	2.624	7/8	1 11/16	3 5/8	1 15/16	1/2	1 3/8	2	3 1/16	6 1/4	6 5/8	6 7/8
5	7	1	7/8-14	3/4-16	1 1/8	1.499	1/2	7/8	1 7/8	15/16	1/4	3/4	1 3/8	2 7/16	5 5/8	6	6 1/4
	1(Std.)	1 3/4	1 1/2-12	1 1/4-12	2	2.374	3/4	1 1/2	3 1/4	1 11/16	1/2	1 1/4	1 7/8	2 15/16	6 3/8	6 13/16	7
	2	3 1/2	3 1/4-12	2 1/2-12	3 1/2	4.249	1	3	5 1/8	3 3/8	5/8	1 5/8	2 1/4	3 5/16	6 3/4	7 3/16	7 3/8
	3	2	1 3/4-12	1 1/2-12	2 1/4	2.624	7/8	1 11/16	3 5/8	1 15/16	1/2	1 3/8	2	3 1/16	6 1/2	6 15/16	7 1/8
	4	2 1/2	2 1/4-12	1 7/8-12	3	3.124	1	2 1/16	4 5/8	2 3/8	5/8	1 5/8	2 1/4	3 5/16	6 3/4	7 3/16	7 3/8
	5	3	2 3/4-12	2 1/4-12	3 1/2	3.749	1	2 5/8	5 1/8	2 7/8	5/8	1 5/8	2 1/4	3 5/16	6 3/4	7 3/16	7 3/8
	7	1	7/8-14	3/4-16	1 1/8	1.499	1/2	7/8	1 7/8	15/16	1/4	3/4	1 3/8	2 7/16	5 7/8	6 5/16	6 1/2
6	1(Std.)	1 3/4	1 1/2-12	1 1/4-12	2	2.374	3/4	1 1/2	3 1/8	1 11/16	3/8	1 1/8	1 7/8	3 1/16	6 7/8	7 5/16	7 5/8
	2	4	3 3/4-12	3-12	4	4.749	1	3 3/8	5 1/2	3 7/8	1/2	1 1/2	2 1/4	3 7/16	7 1/4	7 11/16	8
	3	2	1 3/4-12	1 1/2-12	2 1/4	2.624	7/8	1 11/16	3 1/2	1 15/16	3/8	1 1/4	2	3 3/16	7	7 7/16	7 3/4
	4	2 1/2	2 1/4-12	1 7/8-12	3	3.124	1	2 1/16	4 1/2	2 3/8	1/2	1 1/2	2 1/4	3 7/16	7 1/4	7 11/16	8
	5	3	2 3/4-12	2 1/4-12	3 1/2	3.749	1	2 5/8	5	2 7/8	1/2	1 1/2	2 1/4	3 7/16	7 1/4	7 11/16	8
	6	3 1/2	3 1/4-12	2 1/2-12	3 1/2	4.249	1	3	5	3 3/8	1/2	1 1/2	2 1/4	3 7/16	7 1/4	7 11/16	8
	7	1 3/8	1 1/4-12	1-14	1 5/8	1.999	5/8	1 1/8	2 1/2	1 5/16	1/4	7/8	1 5/8	2 13/16	6 5/8	7 1/16	7 3/8

For Cylinder Division Plant Locations – See Page II.



Square Flange Mountings
1" to 6" Bore Sizes

Series 3L Medium Duty Hydraulic Cylinders

Head Square Flange
Style JB
(NFPA Style MF5)

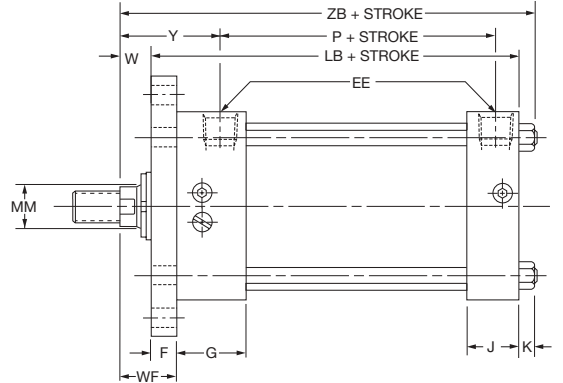
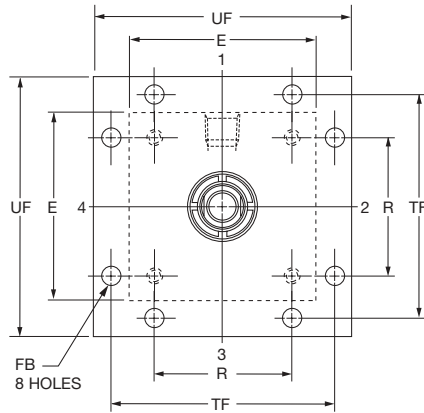
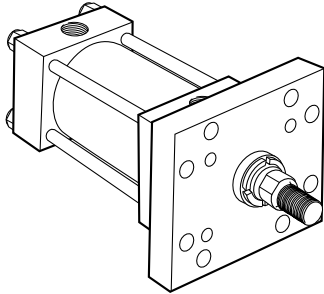

Cap Square Flange
Style HB
(NFPA Style MF6)

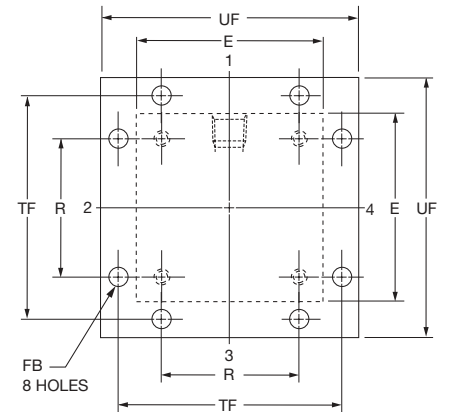
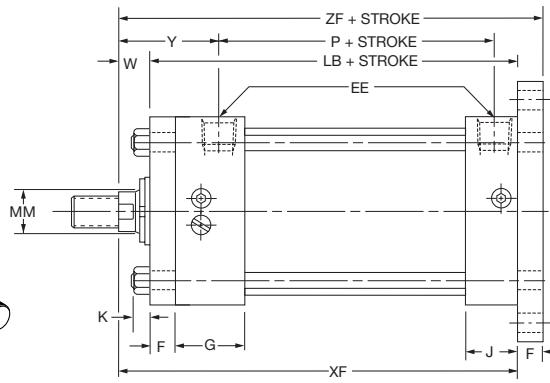
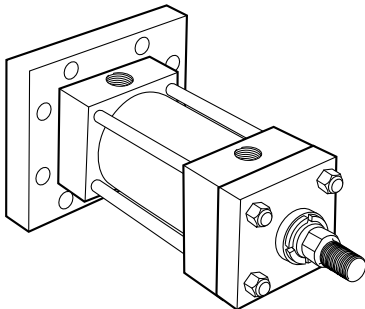

Rod End Dimensions—see table 2

Thread Style 4
(NFPA Style SM)
Small Male

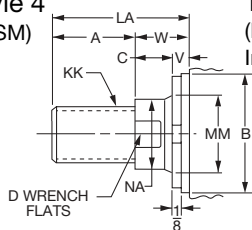

Thread Style 8
(NFPA Style IM)
Intermediate Male

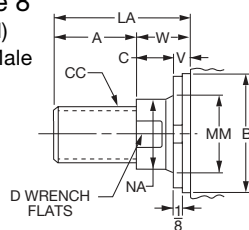

Thread Style 9
(NFPA Style SF)
Small Female

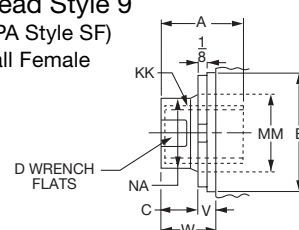

Straight Thread Port Adapters

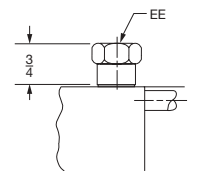

A high strength rod end stud is supplied on thread style 4 through 2" diameter rods and on thread style 8 through 1 3/8" diameter rods. Larger sizes or special rod ends are cut threads. Style 4 rod ends are recommended where the workpiece is secured against the rod shoulder. When the workpiece is

not shouldered, style 4 rod ends are recommended through 2" piston rod diameters and style 8 rod ends are recommended on larger diameters. Use style 9 for applications where female rod end threads are required. If rod end is not specified, style 4 will be supplied.

Used on 1 1/2" bore cap end and on head end of 1 1/2" bore with Code 2 rod.

"Specials" Thread Style 3

To order, specify "Style 3" and give desired dimensions for CC or KK, A and LA. If otherwise special, furnish dimensional sketch.

For additional information – call your local Parker Cylinder Distributor.

Series 3L Medium Duty Hydraulic Cylinders

Square Flange Mountings
1" to 6" Bore Sizes

Table 1—Envelope and Mounting Dimensions

Bore	AA	BB	DD	E	EE		F	FB	G	J	K	R	TF	UF	Add Stroke	
					NPTF [†]	SAE*									LB	P
1 [‡]	1.53	3/4	10-24	■	1/4 [†]	6 [#]	3/8	1/4	11/2	1	3/16	1.08	2	2 1/2	37/8	2 1/8
1 1/2	2.02	1	1/4-28	2	3/8 [†]	6 [#]	3/8	5/16	11/2	1	1/4	1.43	2 3/4	3 3/8	4	2 1/4
2	2.6	1 1/8	5/16-24	2 1/2	3/8 [†]	6	3/8	3/8	11/2	1	5/16	1.84	3 3/8	4 1/8	4	2 1/4
2 1/2	3.1	1 1/8	5/16-24	3	3/8 [†]	6	3/8	3/8	11/2	1	5/16	2.19	3 7/8	4 5/8	4 1/8	2 3/8
3 1/4	3.9	1 3/8	3/8-24	3 3/4	1/2	10	5/8	7/16	13/4	1 1/4	3/8	2.76	4 11/16	5 1/2	4 7/8	2 5/8
4	4.7	1 3/8	3/8-24	4 1/2	1/2	10	5/8	7/16	13/4	1 1/4	3/8	3.32	5 7/16	6 1/4	4 7/8	2 5/8
5	5.8	1 13/16	1/2-20	5 1/2	1/2	10	5/8	9/16	13/4	1 1/4	7/16	4.10	6 5/8	7 5/8	5 1/8	2 7/8
6	6.9	1 13/16	1/2-20	6 1/2	3/4	12	3/4	9/16	2	1 1/2	7/16	4.88	7 5/8	8 5/8	5 3/4	3 1/8

○ NPTF ports will be furnished as standard unless SAE straight thread ports are specified.

* SAE straight thread ports are indicated by port number.

‡ Cushion adjusting needle valve for 1" bore projects beyond sides of head and cap.

† On 1", 1 1/2", 2" and 2 1/2" bore sizes, the head end (only) pipe thread is not full depth on cylinders with No. 2 rods. Minimum of 3 full threads available.

■ 1" bore 3L heads are rectangular — see page 20.

Straight thread ports on 1 1/2" bore cap end, and head end with Code 2 rod, require an adapter fitting. (See "Straight Thread Port Adapter" drawing on opposite page.) Adapters are furnished as standard.

Table 2—Rod Dimensions

Bore	Rod No.	Rod Dia. MM	Thread		Rod Extensions and Pilot Dimensions								Add Stroke				
			Style 8 CC	Style 4 & 9 KK	A	+0.000 -0.002 B	C	D	LA	NA	V	W	WF	Y	XF	ZB	ZF
1	1(Std.)	1/2	7/16-20	5/16-24	5/8	.999	3/8	3/8	11/4	7/16	1/4	5/8	1	115/16	4 1/2	4 11/16	4 7/8
	2	5/8	1/2-20	7/16-20	3/4	1.124	3/8	1/2	13/8	9/16	1/4	5/8	1	115/16	4 1/2	4 11/16	4 7/8
1 1/2	1(Std.)	5/8	1/2-20	7/16-20	3/4	1.124	3/8	1/2	13/8	9/16	1/4	5/8	1	115/16	4 5/8	4 7/8	5
	2	1	7/8-14	3/4-16	1 1/8	1.499	1/2	7/8	2 1/8	15/16	1/2	1	1 3/8	25/16	5	5 1/4	5 3/8
2	1(Std.)	5/8	1/2-20	7/16-20	3/4	1.124	3/8	1/2	13/8	9/16	1/4	5/8	1	115/16	4 5/8	4 15/16	5
	2	1 3/8	1 1/4-12	1-14	1 5/8	1.999	5/8	1 1/8	2 7/8	15/16	5/8	1 1/4	1 5/8	29/16	5 1/4	5 9/16	5 5/8
	3	1	7/8-14	3/4-16	1 1/8	1.499	1/2	7/8	2 1/8	15/16	1/2	1	1 3/8	25/16	5	5 5/16	5 3/8
2 1/2	1(Std.)	1	7/8-14	3/4-16	1 1/8	1.499	1/2	7/8	2 1/8	15/16	1/2	1	1 3/8	25/16	5 1/8	5 1/16	5 1/2
	2	1 3/4	1 1/2-12	1 1/4-12	2	2.374	3/4	1 1/2	3 1/2	1 11/16	3/4	1 1/2	1 7/8	213/16	5 5/8	5 5/16	6
	3	1 3/8	1 1/4-12	1-14	1 5/8	1.999	5/8	1 1/8	2 7/8	15/16	5/8	1 1/4	1 5/8	29/16	5 3/8	5 11/16	5 3/4
	7	5/8	1/2-20	7/16-20	3/4	1.124	3/8	1/2	13/8	9/16	1/4	5/8	1	115/16	4 3/4	5 1/16	5 1/8
3 1/4	1(Std.)	1	7/8-14	3/4-16	1 1/8	1.499	1/2	7/8	1 7/8	15/16	1/4	3/4	1 3/8	27/16	5 5/8	6	6 1/4
	2	2	1 3/4-12	1 1/2-12	2 1/4	2.624	7/8	1 11/16	3 5/8	1 15/16	1/2	1 3/8	2	31/16	6 1/4	6 5/8	6 7/8
	3	1 3/8	1 1/4-12	1-14	1 5/8	1.999	5/8	1 1/8	2 5/8	15/16	3/8	1	1 5/8	21 1/16	5 7/8	6 1/4	6 1/2
	4	1 3/4	1 1/2-12	1 1/4-12	2	2.374	3/4	1 1/2	3 1/4	1 11/16	1/2	1 1/4	1 7/8	215/16	6 1/8	6 1/2	6 3/4
4	1(Std.)	1 3/8	1 1/4-12	1-14	1 5/8	1.999	5/8	1 1/8	2 5/8	15/16	3/8	1	1 5/8	21 1/16	5 7/8	6 1/4	6 1/2
	2	2 1/2	2 1/4-12	1 7/8-12	3	3.124	1	2 1/16	4 5/8	2 3/8	5/8	1 5/8	2 1/4	35/16	6 1/2	6 7/8	7 1/8
	3	1 3/4	1 1/2-12	1 1/4-12	2	2.374	3/4	1 1/2	3 1/4	1 11/16	1/2	1 1/4	1 7/8	215/16	6 1/8	6 1/2	6 3/4
	4	2	1 3/4-12	1 1/2-12	2 1/4	2.624	7/8	1 11/16	3 5/8	1 15/16	1/2	1 3/8	2	31/16	6 1/4	6 5/8	6 7/8
5	7	1	7/8-14	3/4-16	1 1/8	1.499	1/2	7/8	1 7/8	15/16	1/4	3/4	1 3/8	27/16	5 5/8	6	6 1/4
	1(Std.)	1 3/4	1 1/2-12	1 1/4-12	2	2.374	3/4	1 1/2	3 1/4	1 11/16	1/2	1 1/4	1 7/8	215/16	6 3/8	6 13/16	7
	2	3 1/2	3 1/4-12	2 1/2-12	3 1/2	4.249	1	3	5 1/8	3 3/8	5/8	1 5/8	2 1/4	35/16	6 3/4	7 3/16	7 3/8
	3	2	1 3/4-12	1 1/2-12	2 1/4	2.624	7/8	1 11/16	3 5/8	1 15/16	1/2	1 3/8	2	31/16	6 1/2	6 15/16	7 1/8
	4	2 1/2	2 1/4-12	1 7/8-12	3	3.124	1	2 1/16	4 5/8	2 3/8	5/8	1 5/8	2 1/4	35/16	6 3/4	7 3/16	7 3/8
	5	3	2 3/4-12	2 1/4-12	3 1/2	3.749	1	2 5/8	5 1/8	2 7/8	5/8	1 5/8	2 1/4	35/16	6 3/4	7 3/16	7 3/8
6	7	1	7/8-14	3/4-16	1 1/8	1.499	1/2	7/8	1 7/8	15/16	1/4	3/4	1 3/8	27/16	5 7/8	6 5/16	6 1/2
	8	1 3/8	1 1/4-12	1-14	1 5/8	1.999	5/8	1 1/8	2 5/8	15/16	3/8	1	1 5/8	21 1/16	6 1/8	6 9/16	6 3/4
	1(Std.)	1 3/4	1 1/2-12	1 1/4-12	2	2.374	3/4	1 1/2	3 1/8	1 11/16	3/8	1 1/8	1 7/8	31/16	6 7/8	7 5/16	7 5/8
	2	4	3 3/4-12	3-12	4	4.749	1	3 3/8	5 1/2	3 7/8	1/2	1 1/2	2 1/4	37/16	7 1/4	7 11/16	8
	3	2	1 3/4-12	1 1/2-12	2 1/4	2.624	7/8	1 11/16	3 1/2	1 15/16	3/8	1 1/4	2	33/16	7	7 7/16	7 3/4
	4	2 1/2	2 1/4-12	1 7/8-12	3	3.124	1	2 1/16	4 1/2	2 3/8	1/2	1 1/2	2 1/4	37/16	7 1/4	7 11/16	8
	5	3	2 3/4-12	2 1/4-12	3 1/2	3.749	1	2 5/8	5	2 7/8	1/2	1 1/2	2 1/4	37/16	7 1/4	7 11/16	8
6	3 1/2	3 1/4-12	2 1/2-12	3 1/2	4.249	1	3	5	3 3/8	1/2	1 1/2	2 1/4	37/16	7 1/4	7 11/16	8	
7	1 3/8	1 1/4-12	1-14	1 5/8	1.999	5/8	1 1/8	2 1/2	1 5/16	1/4	7/8	1 5/8	213/16	6 5/8	7 1/16	7 3/8	

Table 3—Envelope and Mounting Dimensions

For Cylinder Division Plant Locations – See Page II.



**Side Lugs, Centerline Lugs
and Side Tapped Mountings
1" to 6" Bore Sizes**

**Series 3L
Medium Duty Hydraulic Cylinders**

**Side Lug
Style C
(NFFA Style MS2)**

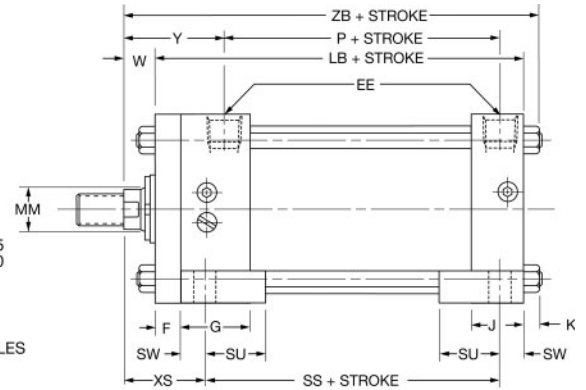
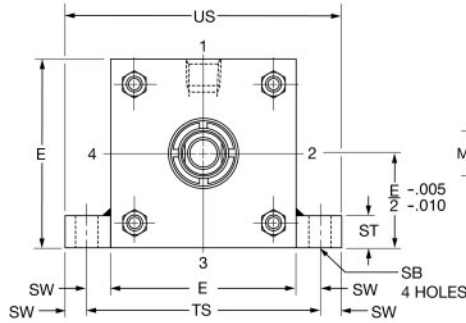
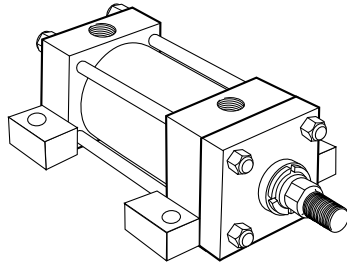

**Centerline Lugs
Style E
(NFFA Style MS3)**

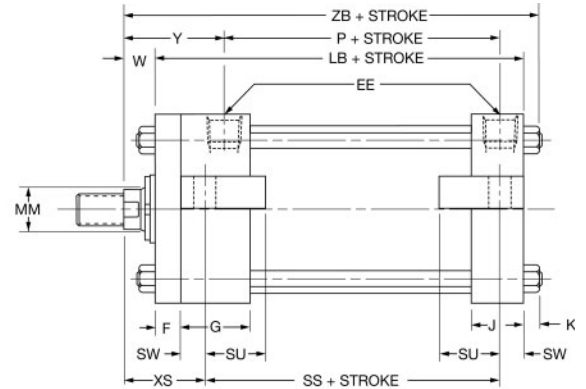
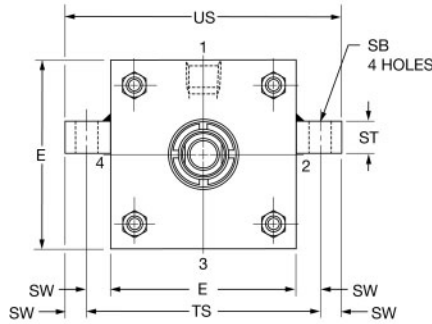
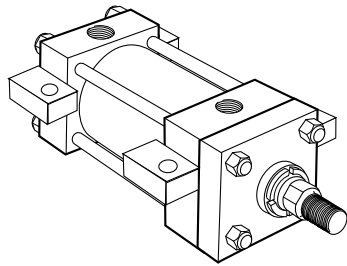

Rod End Dimensions—see table 2

**Thread Style 4
(NFFA Style SM)
Small Male**

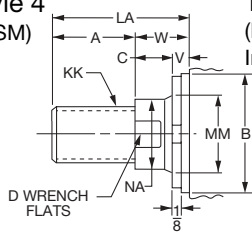

**Thread Style 8
(NFFA Style IM)
Intermediate Male**

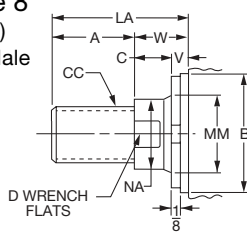

**Thread Style 9
(NFFA Style SF)
Small Female**

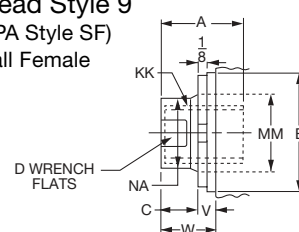

**Straight Thread
Port Adapters**

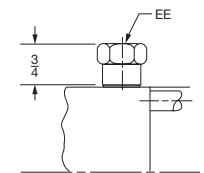

A high strength rod end stud is supplied on thread style 4 through 2" diameter rods and on thread style 8 through 1 3/8" diameter rods. Larger sizes or special rod ends are cut threads. Style 4 rod ends are recommended where the workpiece is secured against the rod shoulder. When the workpiece is

not shouldered, style 4 rod ends are recommended through 2" piston rod diameters and style 8 rod ends are recommended on larger diameters. Use style 9 for applications where female rod end threads are required. If rod end is not specified, style 4 will be supplied.

Used on 1 1/2" bore cap end and on head end of 1 1/2" bore with Code 2 rod.

"Specials" Thread Style 3

To order, specify "Style 3" and give desired dimensions for CC or KK, A and LA. If otherwise special, furnish dimensional sketch.

For additional information – call your local Parker Cylinder Distributor.

Series 3L Medium Duty Hydraulic Cylinders

Side Lugs, Centerline Lugs
and Side Tapped Mountings
1" to 6" Bore Sizes

Table 1—Envelope and Mounting Dimensions

Bore	E	EE		F	G	J	K	SB*	ST	SU	SW	TS	US	Add Stroke		
		NPTF†	SAE*											LB	P	SS
1 [‡]	■	1/4†	6#	3/8	1 1/2	1	3/16	9/32*	5/16*	3/4*	5/16*	2 1/8*	2 3/4*	3 7/8	2 1/8	2 7/8*
1 1/2	2	3/8†	6#	3/8	1 1/2	1	1/4	7/16	1/2	15/16	3/8	2 3/4	3 1/2	4	2 1/4	2 7/8
2	2 1/2	3/8†	6	3/8	1 1/2	1	5/16	7/16	1/2	15/16	3/8	3 1/4	4	4	2 1/4	2 7/8
2 1/2	3	3/8†	6	3/8	1 1/2	1	5/16	7/16	1/2	15/16	3/8	3 3/4	4 1/2	4 1/8	2 3/8	3
3 1/4	3 3/4	1/2	10	5/8	1 3/4	1 1/4	3/8	9/16	3/4	1 1/4	1/2	4 3/4	5 3/4	4 7/8	2 5/8	3 1/4
4	4 1/2	1/2	10	5/8	1 3/4	1 1/4	3/8	9/16	3/4	1 1/4	1/2	5 1/2	6 1/2	4 7/8	2 5/8	3 1/4
5	5 1/2	1/2	10	5/8	1 3/4	1 1/4	7/16	13/16	1	1 9/16	1 1/16	6 7/8	8 1/4	5 1/8	2 7/8	3 1/8
6	6 1/2	3/4	12	3/4	2	1 1/2	7/16	13/16	1	1 9/16	1 1/16	7 7/8	9 1/4	5 3/4	3 1/8	3 5/8

† On NPTF ports will be furnished as standard unless SAE straight thread ports are specified.

* SAE straight thread ports are indicated by port number.

‡ Cushion adjusting needle valve for 1" bore projects beyond sides of head and cap.

† On 1", 1 1/2", 2" and 2 1/2" bore sizes, the head end (only) pipe thread is not full depth on cylinders with No. 2 rods. Minimum of 3 full threads available.

■ 1" bore 3L heads are rectangular — see page 20.

Straight thread ports on 1 1/2" bore cap end, and head end with Code 2 rod, require an adapter fitting. (See "Straight Thread Port Adapter" drawing on opposite page.) Adapters are furnished as standard.

Table 2—Rod Dimensions

Bore	Rod No.	Rod Dia. MM	Thread		Rod Extensions and Pilot Dimensions								XS	Y	Add Stroke ZB
			Style 8 CC	Style 4 & 9 KK	A	+0.000 -0.002 B	C	D	LA	NA	V	W			
1	1(Std.)	1/2	7/16-20	5/16-24	5/8	.999	3/8	3/8	1 1/4	7/16	1/4	5/8	1 5/16*	1 15/16	4 11/16
	2	5/8	1/2-20	7/16-20	3/4	1.124	3/8	1/2	1 3/8	9/16	1/4	5/8	1 5/16*	1 15/16	4 11/16
1 1/2	1(Std.)	5/8	1/2-20	7/16-20	3/4	1.124	3/8	1/2	1 3/8	9/16	1/4	5/8	1 3/8	1 15/16	4 7/8
	2	1	7/8-14	3/4-16	1 1/8	1.499	1/2	7/8	2 1/8	1 5/16	1/2	1	1 3/4	2 5/16	5 1/4
2	1(Std.)	5/8	1/2-20	7/16-20	3/4	1.124	3/8	1/2	1 3/8	9/16	1/4	5/8	1 3/8	1 15/16	4 5/16
	2	1 3/8	1 1/4-12	1-14	1 5/8	1.999	5/8	1 1/8	2 7/8	1 5/16	5/8	1 1/4	2	2 9/16	5 9/16
	3	1	7/8-14	3/4-16	1 1/8	1.499	1/2	7/8	2 1/8	1 5/16	1/2	1	1 3/4	2 5/16	5 5/16
2 1/2	1(Std.)	1	7/8-14	3/4-16	1 1/8	1.499	1/2	7/8	2 1/8	1 5/16	1/2	1	1 3/4	2 5/16	5 7/16
	2	1 3/4	1 1/2-12	1 1/4-12	2	2.374	3/4	1 1/2	3 1/2	1 11/16	3/4	1 1/2	2 1/4	2 13/16	5 5/16
	3	1 3/8	1 1/4-12	1-14	1 5/8	1.999	5/8	1 1/8	2 7/8	1 5/16	5/8	1 1/4	2	2 9/16	5 11/16
	7	5/8	1/2-20	7/16-20	3/4	1.124	3/8	1/2	1 3/8	9/16	1/4	5/8	1 3/8	1 15/16	5 1/16
3 1/4	1(Std.)	1	7/8-14	3/4-16	1 1/8	1.499	1/2	7/8	1 7/8	1 5/16	1/4	3/4	1 7/8	2 7/16	6
	2	2	1 3/4-12	1 1/2-12	2 1/4	2.624	7/8	1 11/16	3 5/8	1 15/16	1/2	1 3/8	2 1/2	3 1/16	6 5/8
	3	1 3/8	1 1/4-12	1-14	1 5/8	1.999	5/8	1 1/8	2 5/8	1 5/16	3/8	1	2 1/8	2 11/16	6 1/4
	4	1 3/4	1 1/2-12	1 1/4-12	2	2.374	3/4	1 1/2	3 1/4	1 11/16	1/2	1 1/4	2 3/8	2 15/16	6 1/2
4	1(Std.)	1 3/8	1 1/4-12	1-14	1 5/8	1.999	5/8	1 1/8	2 5/8	1 5/16	3/8	1	2 1/8	2 11/16	6 1/4
	2	2 1/2	2 1/4-12	1 7/8-12	3	3.124	1	2 1/16	4 5/8	2 3/8	5/8	1 5/8	2 3/4	3 5/16	6 7/8
	3	1 3/4	1 1/2-12	1 1/4-12	2	2.374	3/4	1 1/2	3 1/4	1 11/16	1/2	1 1/4	2 3/8	2 15/16	6 1/2
	4	2	1 3/4-12	1 1/2-12	2 1/4	2.624	7/8	1 11/16	3 5/8	1 15/16	1/2	1 3/8	2 1/2	3 1/16	6 5/8
5	7	1	7/8-14	3/4-16	1 1/8	1.499	1/2	7/8	1 7/8	1 5/16	1/4	3/4	2 1/16	2 7/16	6
	1(Std.)	1 3/4	1 1/2-12	1 1/4-12	2	2.374	3/4	1 1/2	3 1/4	1 11/16	1/2	1 1/4	2 9/16	2 15/16	6 13/16
	2	3 1/2	3 1/4-12	2 1/2-12	3 1/2	4.249	1	3	5 1/8	3 3/8	5/8	1 5/8	2 15/16	3 5/16	7 3/16
	3	2	1 3/4-12	1 1/2-12	2 1/4	2.624	7/8	1 11/16	3 5/8	1 15/16	1/2	1 3/8	2 11/16	3 1/16	6 5/16
	4	2 1/2	2 1/4-12	1 7/8-12	3	3.124	1	2 1/16	4 5/8	2 3/8	5/8	1 5/8	2 15/16	3 5/16	7 3/16
	5	3	2 3/4-12	2 1/4-12	3 1/2	3.749	1	2 5/8	5 1/8	2 7/8	5/8	1 5/8	2 15/16	3 5/16	7 3/16
6	7	1	7/8-14	3/4-16	1 1/8	1.499	1/2	7/8	1 7/8	1 5/16	1/4	3/4	2 1/16	2 7/16	6 5/16
	8	1 3/8	1 1/4-12	1-14	1 5/8	1.999	5/8	1 1/8	2 5/8	1 5/16	3/8	1	2 5/16	2 11/16	6 9/16
	1(Std.)	1 3/4	1 1/2-12	1 1/4-12	2	2.374	3/4	1 1/2	3 1/8	1 11/16	3/8	1 1/8	2 9/16	3 1/16	7 5/16
	2	4	3 3/4-12	3-12	4	4.749	1	3 3/8	5 1/2	3 7/8	1/2	1 1/2	2 15/16	3 7/16	7 11/16
	3	2	1 3/4-12	1 1/2-12	2 1/4	2.624	7/8	1 11/16	3 1/2	1 15/16	3/8	1 1/4	2 11/16	3 3/16	7 7/16
	4	2 1/2	2 1/4-12	1 7/8-12	3	3.124	1	2 1/16	4 1/2	2 3/8	1/2	1 1/2	2 15/16	3 7/16	7 11/16
	5	3	2 3/4-12	2 1/4-12	3 1/2	3.749	1	2 5/8	5	2 7/8	1/2	1 1/2	2 15/16	3 7/16	7 11/16
6	3 1/2	3 1/4-12	2 1/2-12	3 1/2	4.249	1	3	5	3 3/8	1/2	1 1/2	2 15/16	3 7/16	7 11/16	
7	1 3/8	1 1/4-12	1-14	1 5/8	1.999	5/8	1 1/8	2 1/2	1 5/16	1/4	7/8	2 5/16	2 13/16	7 1/16	

* Mounting style E not available in 1" bore.

Table 3—Envelope and Mounting Dimensions

B

For Cylinder Division Plant Locations – See Page II.



**Side Tapped and
Side End Lug Mountings
1" to 6" Bore Sizes**

**Series 3L
Medium Duty Hydraulic Cylinders**

**Side Tapped
Style F
(NFFA Style MS4)**

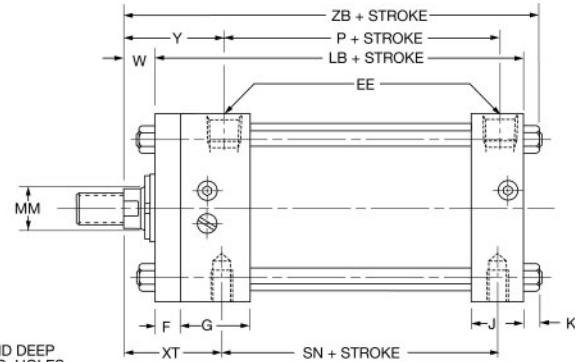
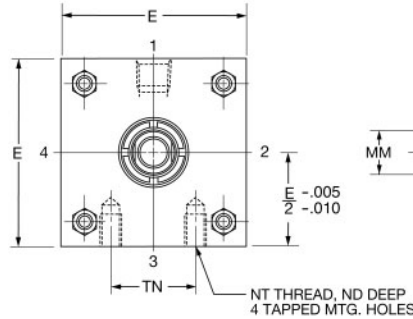
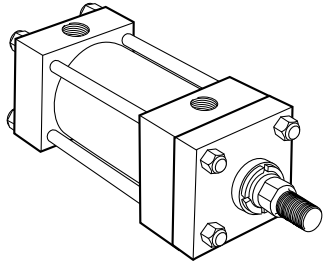

**Side End Lug
Style G
(NFFA Style MS7)**

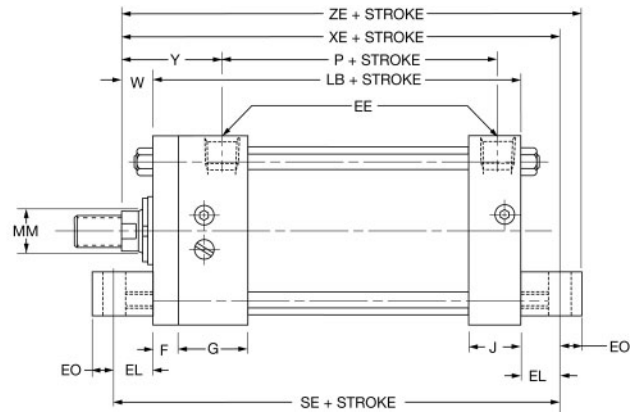
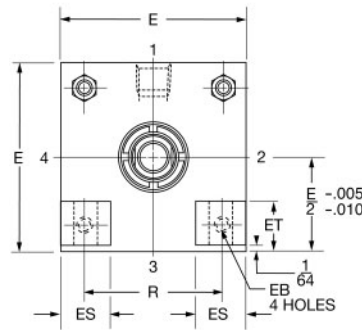
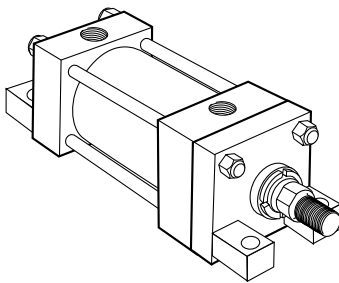

Rod End Dimensions—see table 2

**Thread Style 4
(NFFA Style SM)
Small Male**

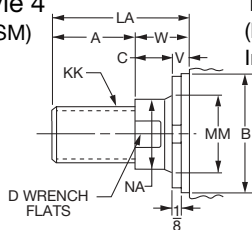

**Thread Style 8
(NFFA Style IM)
Intermediate Male**

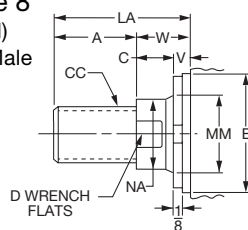

**Thread Style 9
(NFFA Style SF)
Small Female**

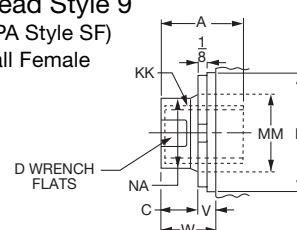

**Straight Thread
Port Adapters**

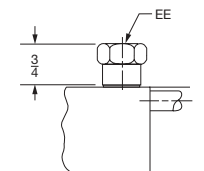

A high strength rod end stud is supplied on thread style 4 through 2" diameter rods and on thread style 8 through 1 3/8" diameter rods. Larger sizes or special rod ends are cut threads. Style 4 rod ends are recommended where the workpiece is secured against the rod shoulder. When the workpiece is

not shouldered, style 4 rod ends are recommended through 2" piston rod diameters and style 8 rod ends are recommended on larger diameters. Use style 9 for applications where female rod end threads are required. If rod end is not specified, style 4 will be supplied.

Used on 1 1/2" bore cap end and on head end of 1 1/2" bore with Code 2 rod.

"Specials" Thread Style 3

To order, specify "Style 3" and give desired dimensions for CC or KK, A and LA. If otherwise special, furnish dimensional sketch.

For additional information – call your local Parker Cylinder Distributor.

Series 3L Medium Duty Hydraulic Cylinders

Side End Angles and
Side End Lug Mountings
1" to 6" Bore Sizes

Table 1—Envelope and Mounting Dimensions

Bore	E	EE				EL	EO	ES	ET	F	G	J	K	NT	TN	R	Add Stroke			
		NPTF [†]	SAE [†]	LB	P												SE	SN		
1 [‡]	■	•	1/4 [†]	6 [†]	•	•	•	•	3/8	1 1/2	1	3/16	10-24	9/16	•	3/8	2 1/8	•	2 1/8	
1 1/2	2	5/16	3/8 [†]	6 [†]	3/4	1/4	9/16	17/32	3/8	1 1/2	1	1/4	1/4-20	5/8	1.43	4	2 1/4	5 1/2	2 1/4	
2	2 1/2	3/8	3/8 [†]	6	15/16	5/16	5/8	5/8	3/8	1 1/2	1	5/16	5/16-18	7/8	1.84	4	2 1/4	5 7/8	2 1/4	
2 1/2	3	3/8	3/8 [†]	6	1 1/16	5/16	13/16	25/32	3/8	1 1/2	1	5/16	3/8-16	1 1/4	2.19	4 1/8	2 3/8	6 1/4	2 3/8	
3 1/4	3 3/4	7/16	1/2	10	7/8	3/8	1	15/16	5/8	1 3/4	1 1/4	3/8	1/2-13	1 1/2	2.76	4 7/8	2 5/8	6 5/8	2 5/8	
4	4 1/2	7/16	1/2	10	1	3/8	1 1/4	15/32	5/8	1 3/4	1 1/4	3/8	1/2-13	2 1/16	3.32	4 7/8	2 5/8	6 7/8	2 5/8	
5	5 1/2	9/16	1/2	10	1 1/16	1/2	1 3/8	13/8	5/8	1 3/4	1 1/4	7/16	5/8-11	2 11/16	4.10	5 1/8	2 7/8	7 1/4	2 7/8	
6	6 1/2	9/16	3/4	12	1	1/2	1 3/4	1 19/32	3/4	2	1 1/2	7/16	3/4-10	3 1/4	4.88	5 3/4	3 1/8	7 3/4	3 1/8	

⊖ NPTF ports will be furnished as standard unless SAE straight thread ports are specified.
[†] SAE straight thread ports are indicated by port number.
[‡] Cushion adjusting needle valve for 1" bore projects beyond sides of head and cap.

[†] On 1", 1 1/2", 2" and 2 1/2" bore sizes, the head end (only) pipe thread is not full depth on cylinders with No. 2 rods. Minimum of 3 full threads available.
 • Mounting style G not available in 1" bore.
 ■ 1" bore 3L heads are rectangular — see page 20.

Straight thread ports on 1 1/2" bore cap end, and head end with Code 2 rod, require an adapter fitting. (See "Straight Thread Port Adapter" drawing on opposite page.) Adapters are furnished as standard.

Table 2—Rod Dimensions

Bore	Rod No.	Rod Dia. MM	Thread		Rod Extensions and Pilot Dimensions								Add Stroke					
			Style 8 CC	Style 4 & 9 KK	A	+0.000 -0.002 B	C	D	LA	NA	V	W	ND	XT	Y	XE	ZB	ZE
1	1(Std.)	1/2	7/16-20	5/16-24	5/8	.999	3/8	3/8	1 1/4	7/16	1/4	5/8	1/4	1 15/16	1 15/16	•	4 11/16	•
	2	5/8	1/2-20	7/16-20	3/4	1.124	3/8	1/2	1 3/8	9/16	1/4	5/8	1/4	1 15/16	1 15/16	•	4 11/16	•
1 1/2	1(Std.)	5/8	1/2-20	7/16-20	3/4	1.124	3/8	1/2	1 3/8	9/16	1/4	5/8	3/16	1 15/16	1 15/16	5 3/8	4 7/8	5 5/8
	2	1	7/8-14	3/4-16	1 1/8	1.499	1/2	7/8	2 1/8	15/16	1/2	1	3/16	2 5/16	2 5/16	5 3/4	5 1/4	6
2	1(Std.)	5/8	1/2-20	7/16-20	3/4	1.124	3/8	1/2	1 3/8	9/16	1/4	5/8	1 1/32	1 15/16	1 15/16	5 9/16	4 15/16	5 7/8
	2	1 3/8	1 1/4-12	1-14	1 5/8	1.999	5/8	1 1/8	2 7/8	15/16	5/8	1 1/4	1 1/32	2 9/16	2 9/16	6 3/16	5 9/16	6 1/2
	3	1	7/8-14	3/4-16	1 1/8	1.499	1/2	7/8	2 1/8	15/16	1/2	1	1 1/32	2 5/16	2 5/16	5 5/16	5 5/16	6 1/4
2 1/2	1(Std.)	1	7/8-14	3/4-16	1 1/8	1.499	1/2	7/8	2 1/8	15/16	1/2	1	7/16	2 5/16	2 5/16	6 3/16	5 7/16	6 1/2
	2	1 3/4	1 1/2-12	1 1/4-12	2	2.374	3/4	1 1/2	3 1/2	1 11/16	3/4	1 1/2	7/16	2 13/16	2 13/16	6 11/16	5 15/16	7
	3	1 3/8	1 1/4-12	1-14	1 5/8	1.999	5/8	1 1/8	2 7/8	15/16	5/8	1 1/4	7/16	2 9/16	2 9/16	6 7/16	5 11/16	6 3/4
	7	5/8	1/2-20	7/16-20	3/4	1.124	3/8	1/2	1 3/8	9/16	1/4	5/8	7/16	1 15/16	1 15/16	5 3/8	5 1/8	6 1/8
3 1/4	1(Std.)	1	7/8-14	3/4-16	1 1/8	1.499	1/2	7/8	1 7/8	15/16	1/4	3/4	1/2	2 7/16	2 7/16	6 1/2	6	6 7/8
	2	2	1 3/4-12	1 1/2-12	2 1/4	2.624	7/8	1 1/2	3 5/8	1 15/16	1/2	1 3/8	1/2	3 1/16	3 1/16	7 1/8	6 5/8	7 1/2
	3	1 3/8	1 1/4-12	1-14	1 5/8	1.999	5/8	1 1/8	2 5/8	15/16	3/8	1	1/2	2 11/16	2 11/16	6 3/4	6 1/4	7 1/8
	4	1 3/4	1 1/2-12	1 1/4-12	2	2.374	3/4	1 1/2	3 1/4	1 11/16	1/2	1 1/4	1/2	2 15/16	2 15/16	7	6 1/2	7 3/8
4	1(Std.)	1 3/8	1 1/4-12	1-14	1 5/8	1.999	5/8	1 1/8	2 5/8	15/16	3/8	1	5/8	2 11/16	2 11/16	6 7/8	6 1/4	7 1/4
	2	2 1/2	2 1/4-12	1 7/8-12	3	3.124	1	2 1/16	4 5/8	2 3/8	5/8	1 5/8	5/8	3 5/16	3 5/16	7 1/2	6 7/8	7 7/8
	3	1 3/4	1 1/2-12	1 1/4-12	2	2.374	3/4	1 1/2	3 1/4	1 11/16	1/2	1 1/4	5/8	2 15/16	2 15/16	7 1/8	6 1/2	7 1/2
	4	2	1 3/4-12	1 1/2-12	2 1/4	2.624	7/8	1 1/2	3 5/8	1 15/16	1/2	1 3/8	5/8	3 1/16	3 1/16	7 1/4	6 5/8	7 5/8
5	7	1	7/8-14	3/4-16	1 1/8	1.499	1/2	7/8	1 7/8	15/16	1/4	3/4	5/8	2 7/16	2 7/16	6 5/8	6	7
	1(Std.)	1 3/4	1 1/2-12	1 1/4-12	2	2.374	3/4	1 1/2	3 1/4	1 11/16	1/2	1 1/4	3/4	2 15/16	2 15/16	7 7/16	6 13/16	7 15/16
	2	3 1/2	3 1/4-12	2 1/2-12	3 1/2	4.249	1	3	5 1/8	3 3/8	5/8	1 5/8	3/4	3 5/16	3 5/16	7 13/16	7 3/16	8 5/16
	3	2	1 3/4-12	1 1/2-12	2 1/4	2.624	7/8	1 1/2	3 5/8	1 15/16	1/2	1 3/8	3/4	3 1/16	3 1/16	7 9/16	6 15/16	8 1/16
	4	2 1/2	2 1/4-12	1 7/8-12	3	3.124	1	2 1/16	4 5/8	2 3/8	5/8	1 5/8	3/4	3 5/16	3 5/16	7 13/16	7 3/16	8 5/16
	5	3	2 3/4-12	2 1/4-12	3 1/2	3.749	1	2 5/8	5 1/8	2 7/8	5/8	1 5/8	3/4	3 5/16	3 5/16	7 13/16	7 3/16	8 5/16
	7	1	7/8-14	3/4-16	1 1/8	1.499	1/2	7/8	1 7/8	15/16	1/4	3/4	3/4	2 7/16	2 7/16	6 15/16	6 5/16	7 7/16
6	1(Std.)	1 3/4	1 1/2-12	1 1/4-12	2	2.374	3/4	1 1/2	3 1/8	1 11/16	3/8	1 1/8	7/8	3 1/16	3 1/16	7 7/8	7 5/16	8 3/8
	2	4	3 3/4-12	3-12	4	4.749	1	3 3/8	5 1/2	3 7/8	1/2	1 1/2	7/8	3 7/16	3 7/16	8 1/4	7 11/16	8 3/4
	3	2	1 3/4-12	1 1/2-12	2 1/4	2.624	7/8	1 1/2	3 1/2	1 15/16	3/8	1 1/4	7/8	3 3/16	3 3/16	8	7 7/16	8 1/2
	4	2 1/2	2 1/4-12	1 7/8-12	3	3.124	1	2 1/16	4 1/2	2 3/8	1/2	1 1/2	7/8	3 7/16	3 7/16	8 1/4	7 11/16	8 3/4
	5	3	2 3/4-12	2 1/4-12	3 1/2	3.749	1	2 5/8	5	2 7/8	1/2	1 1/2	7/8	3 7/16	3 7/16	8 1/4	7 11/16	8 3/4
	6	3 1/2	3 1/4-12	2 1/2-12	3 1/2	4.249	1	3	5	3 3/8	1/2	1 1/2	7/8	3 7/16	3 7/16	8 1/4	7 11/16	8 3/4
	7	1 3/8	1 1/4-12	1-14	1 5/8	1.999	5/8	1 1/8	2 1/2	1 5/16	1/4	7/8	7/8	2 13/16	2 13/16	7 5/8	7 1/16	8 1/8

• Mounting style G not available in 1" bore.
 Caution: When using mounting styles G, check clearance between mounting members and rod attachment or accessory. If necessary, specify longer rod extension to avoid interference with mounting members.

For Cylinder Division Plant Locations – See Page II.



Trunnion Mountings
1" to 6" Bore Sizes

Series 3L Medium Duty Hydraulic Cylinders

Head Trunnion

Style D
(NFPA Style MT1)

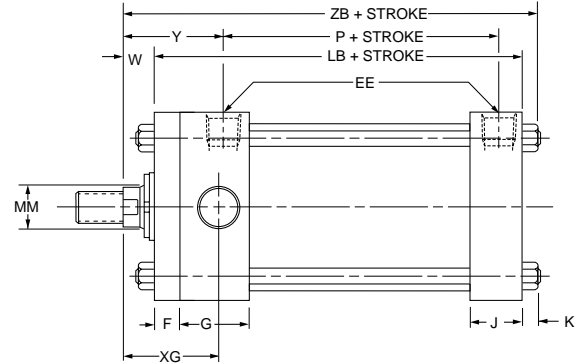
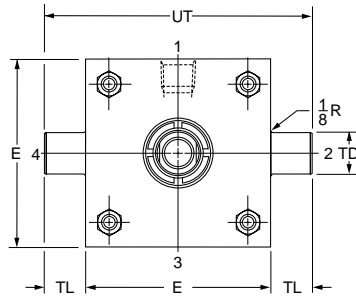
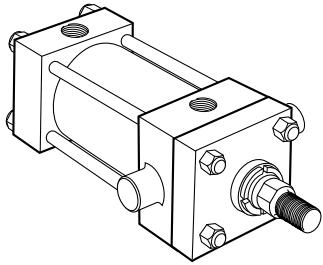

Cap Trunnion

Style DB
(NFPA Style MT2)

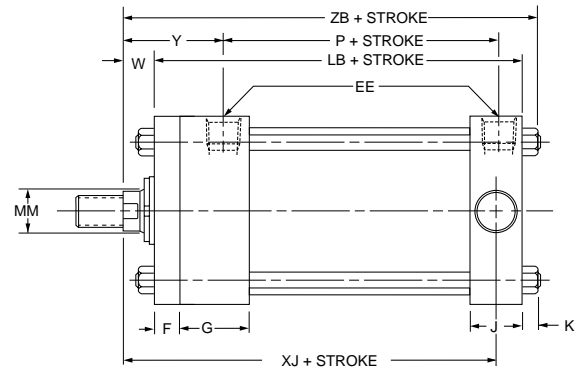
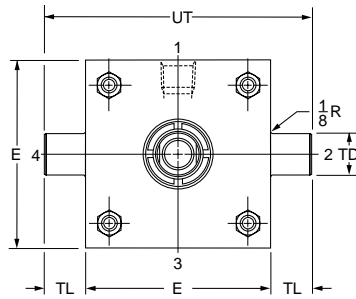
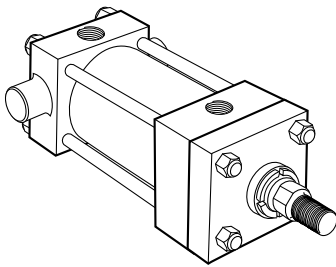

Intermediate Fixed Trunnion

Style DD
(NFPA Style MT4)

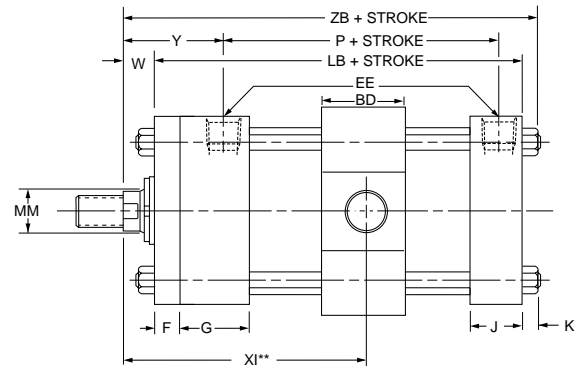
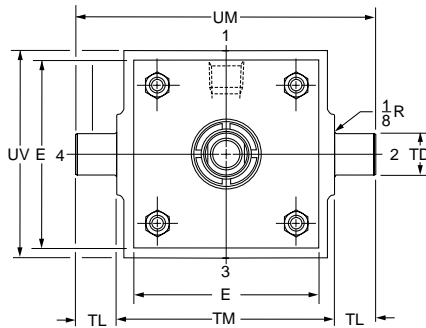
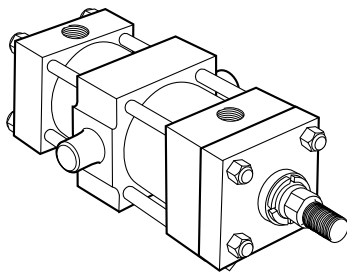

Rod End Dimensions—see table 2

Thread Style 4
(NFPA Style SM)
Small Male

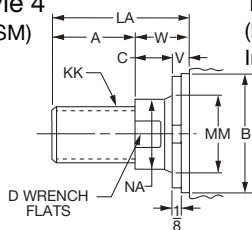

Thread Style 8
(NFPA Style IM)
Intermediate Male

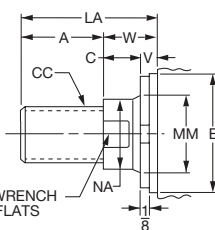

Thread Style 9
(NFPA Style SF)
Small Female

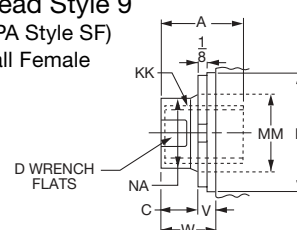

Straight Thread Port Adapters

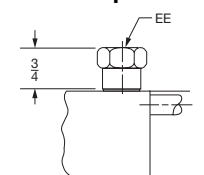

A high strength rod end stud is supplied on thread style 4 through 2" diameter rods and on thread style 8 through 1 3/8" diameter rods. Larger sizes or special rod ends are cut threads. Style 4 rod ends are recommended where the workpiece is secured against the rod shoulder. When the workpiece is

not shouldered, style 4 rod ends are recommended through 2" piston rod diameters and style 8 rod ends are recommended on larger diameters. Use style 9 for applications where female rod end threads are required. If rod end is not specified, style 4 will be supplied.

Used on 1 1/2" bore cap end and on head end of 1 1/2" bore with Code 2 rod.

"Specials" Thread Style 3

To order, specify "Style 3" and give desired dimensions for CC or KK, A and LA. If otherwise special, furnish dimensional sketch.

For additional information – call your local Parker Cylinder Distributor.

Series 3L Medium Duty Hydraulic Cylinders

Trunnion Mountings
1" to 6" Bore Sizes

Table 1—Envelope and Mounting Dimensions

Bore	BD	E	EE		F	G	J	K	+0.000 TD -0.001	TL	TM	UM	UT	UV	Add Stroke		Style DD Min. Stroke
			NPTF†	SAE*											LB	P	
1*	•	■	1/4†	6#	3/8	1 1/2	1	3/16	.750•	3/4•	•	•	3	•	3 7/8	2 1/8	•
1 1/2	1 1/4	2	3/8†	6#	3/8	1 1/2	1	1/4	1.000	1	2 1/2	4 1/2	4	2 1/2	4	2 1/4	1/4
2	1 1/2	2 1/2	3/8†	6	3/8	1 1/2	1	5/16	1.000	1	3	5	4 1/2	3	4	2 1/4	1/2
2 1/2	1 1/2	3	3/8†	6	3/8	1 1/2	1	5/16	1.000	1	3 1/2	5 1/2	5	3 1/2	4 1/8	2 3/8	3/8
3 1/4	2	3 3/4	1/2	10	5/8	1 3/4	1 1/4	3/8	1.000	1	4 1/2	6 1/2	5 3/4	4 1/4	4 7/8	2 5/8	7/8
4	2	4 1/2	1/2	10	5/8	1 3/4	1 1/4	3/8	1.000	1	5 1/4	7 1/4	6 1/2	5	4 7/8	2 5/8	7/8
5	2	5 1/2	1/2	10	5/8	1 3/4	1 1/4	7/16	1.000	1	6 1/4	8 1/4	7 1/2	6	5 1/8	2 7/8	5/8
6	2 1/2	6 1/2	3/4	12	3/4	2	1 1/2	7/16	1.375	1 3/8	7 5/8	10 3/8	9 1/4	7	5 3/4	3 1/8	1 1/8

† On NPTF ports will be furnished as standard unless SAE straight thread ports are specified.

* SAE straight thread ports are indicated by port number.

‡ Cushion adjusting needle valve for 1" bore projects beyond sides of head and cap.

† On 1", 1 1/2", 2" and 2 1/2" bore sizes, the head end (only) pipe thread is not full depth on cylinders with No. 2 rods. Minimum of 3 full threads available.

■ 1" bore 3L heads are rectangular — see page 20.

• Mounting style DD not available in 1" bore.

Straight thread ports on 1 1/2" bore cap end, and head end with Code 2 rod, require an adapter fitting. (See "Straight Thread Port Adapter" drawing on opposite page.) Adapters are furnished as standard.

Table 2—Rod Dimensions

Bore	Rod No.	Rod Dia. MM	Thread		Rod Extensions and Pilot Dimensions								Add Stroke				
			Style 8 CC	Style 4 & 9 KK	A	+0.000 -0.002 B	C	D	LA	NA	V	W	XG	Min.** XI	Y	XJ	ZB
1	1(Std.)	1/2	7/16-20	5/16-24	5/8	.999	3/8	3/8	1 1/4	7/16	1/4	5/8	1 3/4	*	1 15/16	4	4 11/16
	2	5/8	1/2-20	7/16-20	3/4	1.124	3/8	1/2	1 3/8	9/16	1/4	5/8	1 3/4	*	1 15/16	4	4 11/16
1 1/2	1(Std.)	5/8	1/2-20	7/16-20	3/4	1.124	3/8	1/2	1 3/8	9/16	1/4	5/8	1 3/4	3 3/16	1 15/16	4 1/8	4 7/8
	2	1	7/8-14	3/4-16	1 1/8	1.499	1/2	7/8	2 1/8	1 5/16	1/2	1	2 1/8	3 9/16	2 5/16	4 1/2	5 1/4
2	1(Std.)	5/8	1/2-20	7/16-20	3/4	1.124	3/8	1/2	1 3/8	9/16	1/4	5/8	1 3/4	3 5/16	1 15/16	4 1/8	4 5/16
	2	1 3/8	1 1/4-12	1-14	1 5/8	1.999	5/8	1 1/8	2 7/8	1 5/16	5/8	1 1/4	2 3/8	3 15/16	2 9/16	4 3/4	5 9/16
	3	1	7/8-14	3/4-16	1 1/8	1.499	1/2	7/8	2 1/8	1 5/16	1/2	1	2 1/8	3 11/16	2 5/16	4 1/2	5 5/16
2 1/2	1(Std.)	1	7/8-14	3/4-16	1 1/8	1.499	1/2	7/8	2 1/8	1 5/16	1/2	1	2 1/8	3 11/16	2 5/16	4 5/8	5 7/16
	2	1 3/4	1 1/2-12	1 1/4-12	2	2.374	3/4	1 1/2	3 1/2	1 11/16	3/4	1 1/2	2 5/8	4 3/16	2 13/16	5 1/8	5 5/16
	3	1 3/8	1 1/4-12	1-14	1 5/8	1.999	5/8	1 1/8	2 7/8	1 5/16	5/8	1 1/4	2 3/8	3 15/16	2 9/16	4 7/8	5 11/16
	7	5/8	1/2-20	7/16-20	3/4	1.124	3/8	1/2	1 3/8	9/16	1/4	5/8	1 3/4	3 5/16	1 15/16	4 1/4	5 1/16
3 1/4	1(Std.)	1	7/8-14	3/4-16	1 1/8	1.499	1/2	7/8	1 7/8	1 5/16	1/4	3/4	2 1/4	4 3/16	2 7/16	5	6
	2	2	1 3/4-12	1 1/2-12	2 1/4	2.624	7/8	1 11/16	3 5/8	1 15/16	1/2	1 3/8	2 7/8	4 13/16	3 1/16	5 5/8	6 5/8
	3	1 3/8	1 1/4-12	1-14	1 5/8	1.999	5/8	1 1/8	2 5/8	1 5/16	3/8	1	2 1/2	4 7/16	2 11/16	5 1/4	6 1/4
	4	1 3/4	1 1/2-12	1 1/4-12	2	2.374	3/4	1 1/2	3 1/4	1 11/16	1/2	1 1/4	2 3/4	4 11/16	2 15/16	5 1/2	6 1/2
4	1(Std.)	1 3/8	1 1/4-12	1-14	1 5/8	1.999	5/8	1 1/8	2 5/8	1 5/16	3/8	1	2 1/2	4 7/16	2 11/16	5 1/4	6 1/4
	2	2 1/2	2 1/4-12	1 7/8-12	3	3.124	1	2 1/16	4 5/8	2 3/8	5/8	1 5/8	3 1/8	5 1/16	3 5/16	5 7/8	6 7/8
	3	1 3/4	1 1/2-12	1 1/4-12	2	2.374	3/4	1 1/2	3 1/4	1 11/16	1/2	1 1/4	2 3/4	4 11/16	2 15/16	5 1/2	6 1/2
	4	2	1 3/4-12	1 1/2-12	2 1/4	2.624	7/8	1 11/16	3 5/8	1 15/16	1/2	1 3/8	2 7/8	4 13/16	3 1/16	5 5/8	6 5/8
5	7	1	7/8-14	3/4-16	1 1/8	1.499	1/2	7/8	1 7/8	1 5/16	1/4	3/4	2 1/4	4 3/16	2 7/16	5	6
	1(Std.)	1 3/4	1 1/2-12	1 1/4-12	2	2.374	3/4	1 1/2	3 1/4	1 11/16	1/2	1 1/4	2 3/4	4 11/16	2 15/16	5 3/4	6 13/16
	2	3 1/2	3 1/4-12	2 1/2-12	3 1/2	4.249	1	3	5 1/8	3 3/8	5/8	1 5/8	3 1/8	5 1/16	3 5/16	6 1/8	7 3/16
	3	2	1 3/4-12	1 1/2-12	2 1/4	2.624	7/8	1 11/16	3 5/8	1 15/16	1/2	1 3/8	2 7/8	4 13/16	3 1/16	5 7/8	6 15/16
	4	2 1/2	2 1/4-12	1 7/8-12	3	3.124	1	2 1/16	4 5/8	2 3/8	5/8	1 5/8	3 1/8	5 1/16	3 5/16	6 1/8	7 3/16
	5	3	2 3/4-12	2 1/4-12	3 1/2	3.749	1	2 5/8	5 1/8	2 7/8	5/8	1 5/8	3 1/8	5 1/16	3 5/16	6 1/8	7 3/16
	7	1	7/8-14	3/4-16	1 1/8	1.499	1/2	7/8	1 7/8	1 5/16	1/4	3/4	2 1/4	4 3/16	2 7/16	5 1/4	6 5/16
6	1(Std.)	1 3/4	1 1/2-12	1 1/4-12	2	2.374	3/4	1 1/2	3 1/8	1 11/16	3/8	1 1/8	2 7/8	5 3/16	3 1/16	6 1/8	7 5/16
	2	4	3 3/4-12	3-12	4	4.749	1	3 3/8	5 1/2	3 7/8	1/2	1 1/2	3 1/4	5 9/16	3 7/16	6 1/2	7 11/16
	3	2	1 3/4-12	1 1/2-12	2 1/4	2.624	7/8	1 11/16	3 1/2	1 15/16	3/8	1 1/4	3	5 5/16	3 3/16	6 1/4	7 7/16
	4	2 1/2	2 1/4-12	1 7/8-12	3	3.124	1	2 1/16	4 1/2	2 3/8	1/2	1 1/2	3 1/4	5 9/16	3 7/16	6 1/2	7 11/16
	5	3	2 3/4-12	2 1/4-12	3 1/2	3.749	1	2 5/8	5	2 7/8	1/2	1 1/2	3 1/4	5 9/16	3 7/16	6 1/2	7 11/16
	6	3 1/2	3 1/4-12	2 1/2-12	3 1/2	4.249	1	3	5	3 3/8	1/2	1 1/2	3 1/4	5 9/16	3 7/16	6 1/2	7 11/16
	7	1 3/8	1 1/4-12	1-14	1 5/8	1.999	5/8	1 1/8	2 1/2	1 5/16	1/4	7/8	2 5/8	4 15/16	2 13/16	5 7/8	7 1/16

* Mounting style DD not available in 1" bore.

**Dimension XI to be specified by customer.

Table 3—Envelope and Mounting Dimensions

B

For Cylinder Division Plant Locations – See Page II.



Clevis Mountings
1" to 6" Bore Sizes

Series 3L Medium Duty Hydraulic Cylinders

Cap Fixed Clevis
Style BB
(NFPA Style MP1)

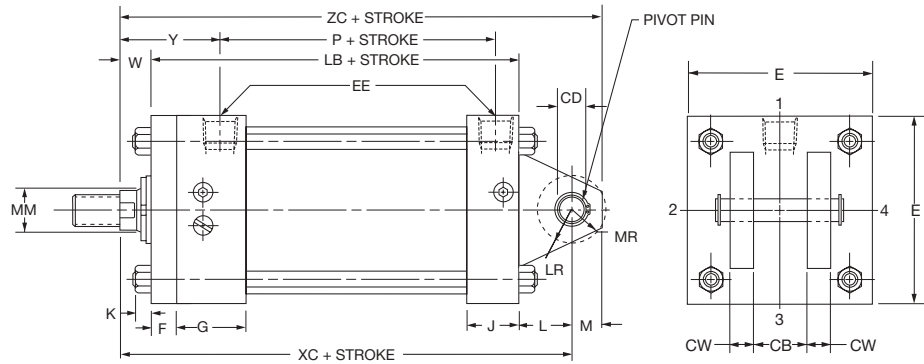
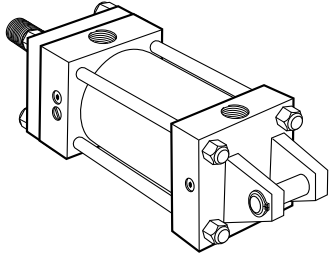

The 1", 4", 5" and 6" bore sizes have tie rod nuts at both ends as shown. Tie rods thread into cap on all other sizes.

Cap Detachable Clevis
Style BC
(NFPA Style MP2)

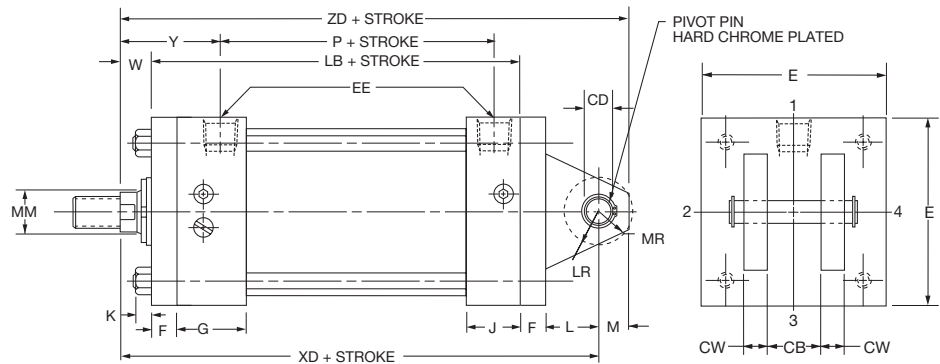
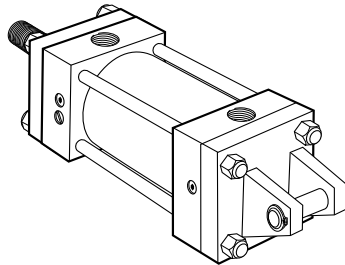

Rod End Dimensions—see table 2

Thread Style 4
(NFPA Style SM)
Small Male

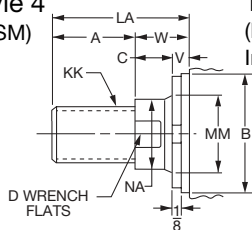

Thread Style 8
(NFPA Style IM)
Intermediate Male

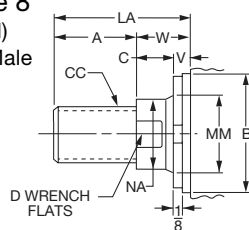

Thread Style 9
(NFPA Style SF)
Small Female

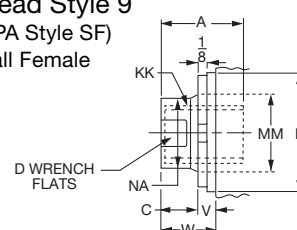

Straight Thread Port Adapters

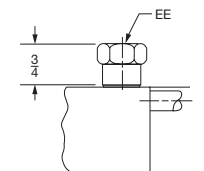

A high strength rod end stud is supplied on thread style 4 through 2" diameter rods and on thread style 8 through 1 3/8" diameter rods. Larger sizes or special rod ends are cut threads. Style 4 rod ends are recommended where the workpiece is secured against the rod shoulder. When the workpiece is

not shouldered, style 4 rod ends are recommended through 2" piston rod diameters and style 8 rod ends are recommended on larger diameters. Use style 9 for applications where female rod end threads are required. If rod end is not specified, style 4 will be supplied.

Used on 1 1/2" bore cap end and on head end of 1 1/2" bore with Code 2 rod.

"Specials" Thread Style 3

To order, specify "Style 3" and give desired dimensions for CC or KK , A and LA . If otherwise special, furnish dimensional sketch.

For additional information – call your local Parker Cylinder Distributor.

Series 3L Medium Duty Hydraulic Cylinders

Clevis Mountings
1" to 6" Bore Sizes

Table 1—Envelope and Mounting Dimensions

Bore	CB	+.000 CD [▲] -.002	CW	E	EE		F	G	J	K	L	LR	M	MR	Add Stroke	
					NPTF [⊖]	SAE [★]									LB	P
1 [†]	•	.441•	•	■	1/4 [†]	6 [#]	3/8	1 1/2	1	3/16	1/2•	1/2•	7/16•	1/2•	37/8	2 1/8
1 1/2	3/4	.501	1/2	2	3/8 [†]	6 [#]	3/8	1 1/2	1	1/4	3/4	3/4	1/2	5/8	4	2 1/4
2	3/4	.501	1/2	2 1/2	3/8 [†]	6	3/8	1 1/2	1	5/16	3/4	3/4	1/2	5/8	4	2 1/4
2 1/2	3/4	.501	1/2	3	3/8 [†]	6	3/8	1 1/2	1	5/16	3/4	3/4	1/2	5/8	4 1/8	2 3/8
3 1/4	1 1/4	.751	5/8	3 3/4	1/2	10	5/8	1 3/4	1 1/4	3/8	1 1/4	1	3/4	15/16	47/8	2 5/8
4	1 1/4	.751	5/8	4 1/2	1/2	10	5/8	1 3/4	1 1/4	3/8	1 1/4	1	3/4	15/16	47/8	2 5/8
5	1 1/4	.751	5/8	5 1/2	1/2	10	5/8	1 3/4	1 1/4	7/16	1 1/4	1	3/4	15/16	5 1/8	2 7/8
6	1 1/2	1.001	3/4	6 1/2	3/4	12	3/4	2	1 1/2	7/16	1 1/2	1 1/4	1	13/16	5 3/4	3 1/8

⊖ NPTF ports will be furnished as standard unless SAE straight thread ports are specified.

★ SAE straight thread ports are indicated by port number.

‡ Cushion adjusting needle valve for 1" bore projects beyond sides of head and cap.

† On 1", 1 1/2", 2" and 2 1/2" bore sizes, the head end (only) pipe thread is not full depth on cylinders with No. 2 rods. Minimum of 3 full threads available.

■ 1" bore 3L heads are rectangular — see page 20.

▲ Dimension CD is pin diameter except in 1" bore.

Straight thread ports on 1 1/2" bore cap end, and head end with Code 2 rod, require an adapter fitting. (See "Straight Thread Port Adapter" drawing on opposite page.) Adapters are furnished as standard.

• In 1" bore size model only, a single fixed eye mounting lug, 7/16" thick, is used. Dimension CD (.441") is hole diameter - pin not furnished

Table 2—Rod Dimensions

Bore	Rod No.	Rod Dia. MM	Thread		Rod Extensions and Pilot Dimensions								Add Stroke				
			Style 8 CC	Style 4 & 9 KK	A	+0.000 -.002 B	C	D	LA	NA	V	W	Y	XC	XD	ZC	ZD
1	1(Std.)	1/2	7/16-20	5/16-24	5/8	.999	3/8	3/8	1 1/4	7/16	1/4	5/8	115/16	5	5 3/8	57/16	5 13/16
	2	5/8	1/2-20	7/16-20	3/4	1.124	3/8	1/2	13/8	9/16	1/4	5/8	115/16	5	5 3/8	57/16	5 13/16
1 1/2	1(Std.)	5/8	1/2-20	7/16-20	3/4	1.124	3/8	1/2	13/8	9/16	1/4	5/8	115/16	5 3/8	5 3/4	57/8	6 1/4
	2	1	7/8-14	3/4-16	1 1/8	1.499	1/2	7/8	2 1/8	15/16	1/2	1	25/16	5 3/4	6 1/8	6 1/4	6 5/8
2	1(Std.)	5/8	1/2-20	7/16-20	3/4	1.124	3/8	1/2	13/8	9/16	1/4	5/8	115/16	5 3/8	5 3/4	57/8	6 1/4
	2	1 3/8	1 1/4-12	1-14	1 5/8	1.999	5/8	1 1/8	27/8	15/16	5/8	1 1/4	29/16	6	6 3/8	6 1/2	6 7/8
	3	1	7/8-14	3/4-16	1 1/8	1.499	1/2	7/8	2 1/8	15/16	1/2	1	25/16	5 3/4	6 1/8	6 1/4	6 5/8
2 1/2	1(Std.)	1	7/8-14	3/4-16	1 1/8	1.499	1/2	7/8	2 1/8	15/16	1/2	1	25/16	5 7/8	6 1/4	6 3/8	6 3/4
	2	1 3/4	1 1/2-12	1 1/4-12	2	2.374	3/4	1 1/2	3 1/2	11 1/16	3/4	1 1/2	213/16	6 3/8	6 3/4	6 7/8	7 1/4
	3	1 3/8	1 1/4-12	1-14	1 5/8	1.999	5/8	1 1/8	27/8	15/16	5/8	1 1/4	29/16	6 1/8	6 1/2	6 5/8	7
	7	5/8	1/2-20	7/16-20	3/4	1.124	3/8	1/2	13/8	9/16	1/4	5/8	115/16	5 1/2	5 7/8	6	6 3/8
3 1/4	1(Std.)	1	7/8-14	3/4-16	1 1/8	1.499	1/2	7/8	17/8	15/16	1/4	3/4	27/16	6 7/8	7 1/2	7 5/8	8 1/4
	2	2	1 3/4-12	1 1/2-12	2 1/4	2.624	7/8	1 1/16	3 5/8	11 5/16	1/2	13/8	31/16	7 1/2	8 1/8	8 1/4	8 7/8
	3	1 3/8	1 1/4-12	1-14	1 5/8	1.999	5/8	1 1/8	25/8	15/16	3/8	1	211/16	7 1/8	7 3/4	7 7/8	8 1/2
	4	1 3/4	1 1/2-12	1 1/4-12	2	2.374	3/4	1 1/2	3 1/4	11 1/16	1/2	1 1/4	215/16	7 3/8	8	8 1/8	8 3/4
4	1(Std.)	1 3/8	1 1/4-12	1-14	1 5/8	1.999	5/8	1 1/8	25/8	15/16	3/8	1	211/16	7 1/8	7 3/4	7 7/8	8 1/2
	2	2 1/2	2 1/4-12	17/8-12	3	3.124	1	2 1/16	45/8	23/8	5/8	1 5/8	35/16	7 3/4	8 3/8	8 1/2	9 1/8
	3	1 3/4	1 1/2-12	1 1/4-12	2	2.374	3/4	1 1/2	3 1/4	11 1/16	1/2	1 1/4	215/16	7 3/8	8	8 1/8	8 3/4
	4	2	1 3/4-12	1 1/2-12	2 1/4	2.624	7/8	1 1/16	3 5/8	11 5/16	1/2	13/8	31/16	7 1/2	8 1/8	8 1/4	8 7/8
5	7	1	7/8-14	3/4-16	1 1/8	1.499	1/2	7/8	17/8	15/16	1/4	3/4	27/16	6 7/8	7 1/2	7 5/8	8 1/4
	1(Std.)	1 3/4	1 1/2-12	1 1/4-12	2	2.374	3/4	1 1/2	3 1/4	11 1/16	1/2	1 1/4	215/16	7 5/8	8 1/4	8 3/8	9
	2	3 1/2	3 1/4-12	2 1/2-12	3 1/2	4.249	1	3	5 1/8	33/8	5/8	1 5/8	35/16	8	8 5/8	8 3/4	9 3/8
	3	2	1 3/4-12	1 1/2-12	2 1/4	2.624	7/8	1 1/16	3 5/8	11 5/16	1/2	1 3/8	31/16	7 3/4	8 3/8	8 1/2	9 1/8
	4	2 1/2	2 1/4-12	17/8-12	3	3.124	1	2 1/16	45/8	23/8	5/8	1 5/8	35/16	8	8 5/8	8 3/4	9 3/8
	5	3	2 3/4-12	2 1/4-12	3 1/2	3.749	1	2 5/8	5 1/8	27/8	5/8	1 5/8	35/16	8	8 5/8	8 3/4	9 3/8
6	7	1	7/8-14	3/4-16	1 1/8	1.499	1/2	7/8	17/8	15/16	1/4	3/4	27/16	7 1/8	7 3/4	7 7/8	8 1/2
	8	1 3/8	1 1/4-12	1-14	1 5/8	1.999	5/8	1 1/8	25/8	15/16	3/8	1	211/16	7 3/8	8	8 1/8	8 3/4
	1(Std.)	1 3/4	1 1/2-12	1 1/4-12	2	2.374	3/4	1 1/2	3 1/8	11 1/16	3/8	1 1/8	31/16	8 3/8	9 1/8	9 3/8	10 1/8
	2	4	3 3/4-12	3-12	4	4.749	1	3 3/8	5 1/2	37/8	1/2	1 1/2	37/16	8 3/4	9 1/2	9 3/4	10 1/2
	3	2	1 3/4-12	1 1/2-12	2 1/4	2.624	7/8	1 1/16	3 1/2	11 5/16	3/8	1 1/4	33/16	8 1/2	9 1/4	9 1/2	10 1/4
	4	2 1/2	2 1/4-12	17/8-12	3	3.124	1	2 1/16	4 1/2	23/8	1/2	1 1/2	37/16	8 3/4	9 1/2	9 3/4	10 1/2
	5	3	2 3/4-12	2 1/4-12	3 1/2	3.749	1	2 5/8	5	27/8	1/2	1 1/2	37/16	8 3/4	9 1/2	9 3/4	10 1/2
6	3 1/2	3 1/4-12	2 1/2-12	3 1/2	4.249	1	3	5	33/8	1/2	1 1/2	37/16	8 3/4	9 1/2	9 3/4	10 1/2	
7	1 3/8	1 1/4-12	1-14	1 5/8	1.999	5/8	1 1/8	2 1/2	15/16	1/4	7/8	213/16	8 1/8	8 7/8	9 1/8	9 7/8	

Table 3—Envelope and Mounting Dimensions

For Cylinder Division Plant Locations – See Page II.

Head Rectangular
1 1/2" to 6" Bore Sizes
1" 3L Head Dimensions

Series 3L
Medium Duty Hydraulic Cylinders

Head Rectangular
Style JJ*

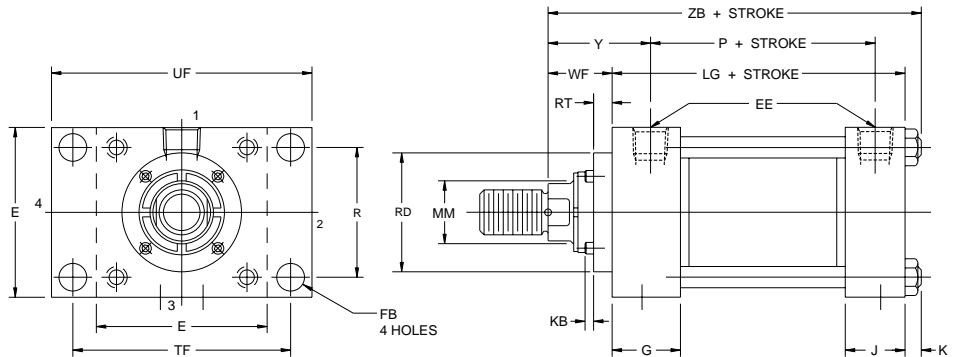
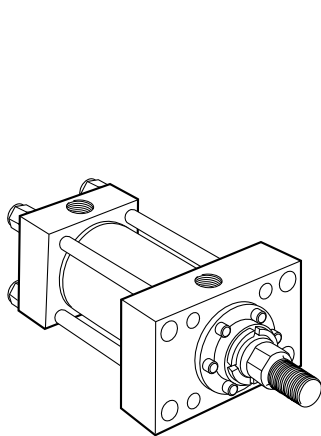

*Parker Style JJ Mount is a Non-NFPA Mount

1" Bore 2A and 3L Series—Envelope and Head Dimensions

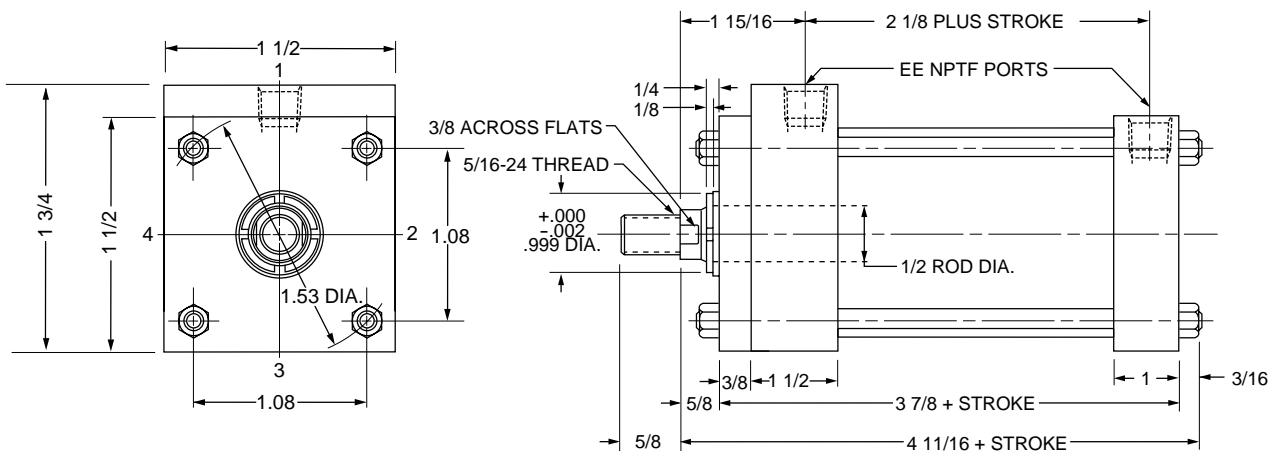

Rod End Dimensions—see table 2

Thread Style 4
(NFPA Style SM)
Small Male

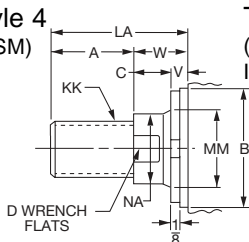

Thread Style 8
(NFPA Style IM)
Intermediate Male

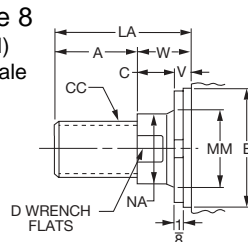

Thread Style 9
(NFPA Style SF)
Small Female

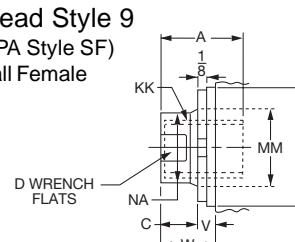

Straight Thread Port Adapters

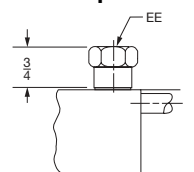

A high strength rod end stud is supplied on thread style 4 through 2" diameter rods and on thread style 8 through 1 3/8" diameter rods. Larger sizes or special rod ends are cut threads. Style 4 rod ends are recommended where the workpiece is secured against the rod shoulder. When the workpiece is

not shouldered, style 4 rod ends are recommended through 2" piston rod diameters and style 8 rod ends are recommended on larger diameters. Use style 9 for applications where female rod end threads are required. If rod end is not specified, style 4 will be supplied.

Used on 1 1/2" bore cap end and on head end of 1 1/2" bore with Code 2 rod.

"Specials" Thread Style 3

To order, specify "Style 3" and give desired dimensions for CC or KK, A and LA. If otherwise special, furnish dimensional sketch.

For additional information – call your local Parker Cylinder Distributor.

Series 3L Medium Duty Hydraulic Cylinders

Head Rectangular
1½" to 6" Bore Sizes

Table 1—Envelope and Mounting Dimensions

Bore	E	EE		FB	G	J*	K	R	UF	TF	Add Stroke	
		NPTF [⊖]	SAE*								LG	P
1½	2	3/8	6#	5/16	1½	1	¼	1.43	2¾	2 ⁵ / ₁₆	3 ⁵ / ₈	2¼
2	2½	3/8	6	3/8	1½	1	5/16	1.84	3 ³ / ₈	2 ⁷ / ₈	3 ⁵ / ₈	2¼
2½	3	3/8	6	3/8	1½	1	5/16	2.19	3¾	3¼	3¾	2 ³ / ₈
3¼	3¾	½	10	7/16	1¾	1¼	3/8	2.76	4 ⁵ / ₈	4	4¼	2 ⁵ / ₈
4	4½	½	10	7/16	1¾	1¼	3/8	3.32	5 ¹ / ₈	4½	4¼	2 ⁵ / ₈
5	5½	½	10	9/16	1¾	1¼	7/16	4.10	6 ⁷ / ₁₆	5 ⁵ / ₈	4½	2 ⁷ / ₈
6	6½	¾	12	9/16	2	1½	7/16	4.88	7¼	6 ⁷ / ₁₆	5	3 ¹ / ₈

⊖ NPTF ports will be furnished as standard unless SAE straight thread ports are specified.

* SAE straight thread ports are indicated by port number.

Note: The Parker style JJ3L mount is not mounting interchangeable with the Parker style J3L.

Straight thread ports on 1½" bore cap end, and head end with Code 2 rod, require an adapter fitting. (See "Straight Thread Port Adapter" drawing on opposite page.)

Table 2—Rod Dimensions

Bore	Rod No.	Rod Dia. MM	Thread		Rod Extensions and Pilot Dimensions								Add Stroke	
			Style 8 CC	Style 4 & 9 KK	A	+0.000 -0.002 B	C	D	RT	Max. RD	KB	WF	Y	ZB
1½	1(Std.)	5/8	1/2-20	7/16-20	¾	1.124	3/8	1/2	1/4	1.967	3/16	1	1 ¹⁵ / ₁₆	4 ⁷ / ₈
	1(Std.)	5/8	1/2-20	7/16-20	¾	1.124	3/8	1/2	1/4	1.967	3/16	1	1 ¹⁵ / ₁₆	4 ¹⁵ / ₁₆
2	3	1	7/8-14	¾-16	1½	1.499	1/2	7/8	3/8	2.467	1/4	13/8	2 ⁵ / ₁₆	5 ⁵ / ₁₆
	1(Std.)	1	7/8-14	¾-16	1½	1.499	1/2	7/8	3/8	2.467	1/4	13/8	2 ⁵ / ₁₆	5 ⁷ / ₁₆
2½	3	1¾	1¼-12	1-14	1 ⁵ / ₈	1.999	5/8	1 ¹ / ₈	3/8	2.967	1/4	1 ⁵ / ₈	2 ⁹ / ₁₆	5 ¹¹ / ₁₆
	1(Std.)	1	7/8-14	¾-16	1½	1.499	1/2	7/8	3/8	2.467	1/4	13/8	2 ⁷ / ₁₆	6
3¼	3	1¾	1¼-12	1-14	1 ⁵ / ₈	1.999	5/8	1 ¹ / ₈	3/8	2.967	1/4	1 ⁵ / ₈	2 ¹¹ / ₁₆	6¼
	1(Std.)	1¾	1¼-12	1-14	1 ⁵ / ₈	1.999	5/8	1 ¹ / ₈	3/8	2.967	1/4	1 ⁵ / ₈	2 ¹¹ / ₁₆	6¼
4	3	1¾	1½-12	1¼-12	2	2.374	¾	1½	3/8	3.467	1/4	17/8	2 ¹⁵ / ₁₆	6½
	1(Std.)	1¾	1½-12	1¼-12	2	2.374	¾	1½	3/8	3.467	1/4	17/8	2 ¹⁵ / ₁₆	6 ¹³ / ₁₆
5	3	2	1¾-12	1½-12	2¼	2.624	7/8	1 ¹¹ / ₁₆	3/8	3.717	1/4	2	3 ¹ / ₁₆	6 ¹⁵ / ₁₆
	1(Std.)	1¾	1½-12	1¼-12	2	2.374	¾	1½	3/8	3.467	1/4	17/8	3 ¹ / ₁₆	7 ⁵ / ₁₆
6	3	2	1¾-12	1½-12	2¼	2.624	7/8	1 ¹¹ / ₁₆	3/8	3.717	1/4	2	3 ³ / ₁₆	7 ⁷ / ₁₆
	1(Std.)	1¾	1½-12	1¼-12	2	2.374	¾	1½	3/8	3.467	1/4	17/8	3 ¹ / ₁₆	7 ⁵ / ₁₆

Table 3—Envelope and Mounting Dimensions

For Cylinder Division Plant Locations – See Page II.



B

**Tie Rod, Head Square and Cap Square Mountings
8" Bore Size**

**Series 3L
Medium Duty Hydraulic Cylinders**

**Tie Rods Extended
Style TB
(NFFPA Style MX3)**

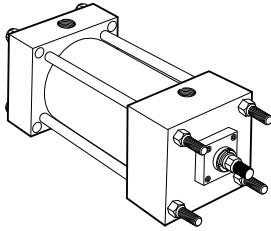

Style TB (NFFPA MX3) Head Tie Rods Extended, illustrated: Style TC (NFFPA MX2), Cap Tie Rods Extended; and Style TD (NFFPA MX1), Both Ends Tie Rods Extended are also available. All "T" styles can be dimensioned from Style TB drawing at right.

Mounting styles TB and TD not offered in 8" bore size, rod codes #2, 9 and 0.

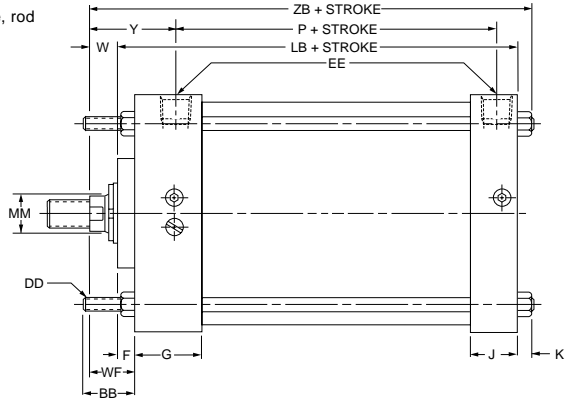
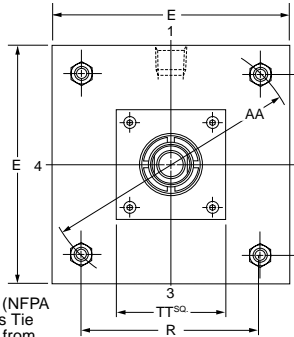

**Head Square Flange
Style JB
(NFFPA Style ME3)**

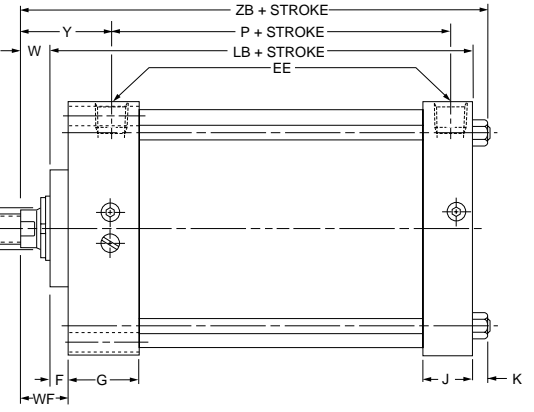
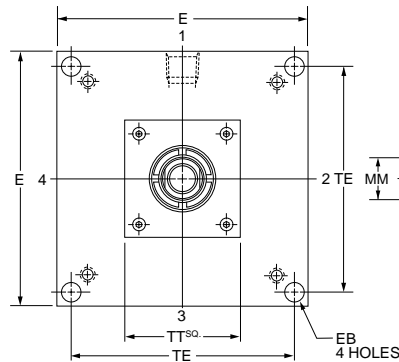
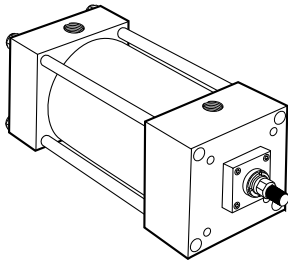

**Cap Square Flange
Style HB
(NFFPA Style ME4)**

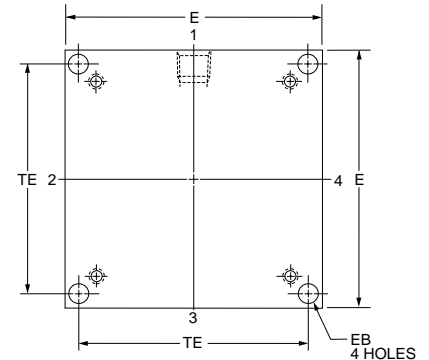
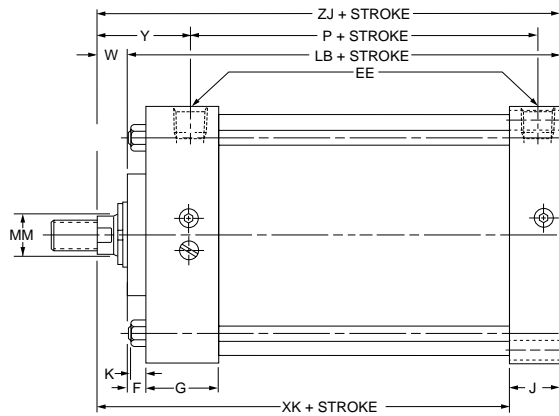
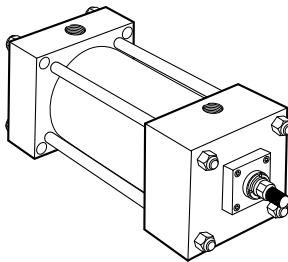

Rod End Dimensions — see table 2

**Thread Style 4
(NFFPA Style SM)
Small Male**

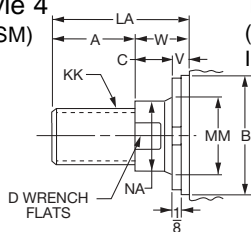

**Thread Style 8
(NFFPA Style IM)
Intermediate Male**

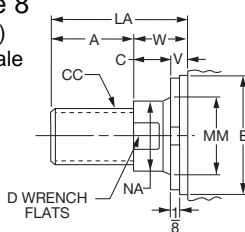

**Thread Style 9
(NFFPA Style SF)
Small Female**

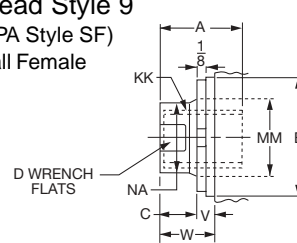

"Special" Thread Style 3

Special thread, extension, rod eye, blank, etc., are also available.

To order, specify "Style 3" and give desired dimensions for CC or KK, A and LA. If otherwise special, furnish dimensional sketch.

A high strength rod end stud is supplied on thread style 4 through 2" diameter rods and on thread style 8 through 1 3/8" diameter rods. Larger sizes or special rod ends are cut threads. Style 4 rod ends are recommended where the workpiece is secured against the rod shoulder. When the workpiece is not shouldered, style 4 rod ends are recommended through 2" piston rod

diameters and style 8 rod ends are recommended on larger diameters. Use style 9 for applications where female rod end threads are required. If rod end is not specified, style 4 will be supplied. On 4 1/2" rods and above, 4 .515 dia. spanner wrench holes will be provided instead of wrench flats.

For additional information – call your local Parker Cylinder Distributor.

Series 3L Medium Duty Hydraulic Cylinders

Tie Rod, Head Square and
Cap Square Mountings
8" Bore Size

Table 1—Envelope and Mounting Dimensions—Style T

Bore	AA	BB	DD	E	EE		F	G	J	K	R	Add Stroke	
					NPTF ^o	SAE*						LB	P
8	9.1	2 ⁵ / ₁₆	5 ⁵ / ₈ -18	8 ¹ / ₂	³ / ₄	12	³ / ₄	2	1 ¹ / ₂	⁹ / ₁₆	6.44	5 ⁷ / ₈	3 ¹ / ₄

^o NPTF ports will be furnished as standard unless SAE straight thread ports are specified.
* SAE straight thread ports are indicated by port number.

Table 2—Rod Dimensions—Style T

Bore	Rod No.	Rod Dia. MM	Thread		Rod Extensions and Pilot Dimensions								TT	WF	Y	Add Stroke ZB
			Style 8 CC	Style 4 & 9 KK	A	+0.000 -.002 B	C	D	LA	NA	V	W				
8	1(Std.)	2	1 ³ / ₄ -12	1 ¹ / ₂ -12	2 ¹ / ₄	2.624	⁷ / ₈	1 ¹¹ / ₁₆	3 ¹ / ₂	1 ⁵ / ₁₆	³ / ₈	1 ¹ / ₄	4	2	3 ³ / ₁₆	7 ¹¹ / ₁₆
	2	5 ¹ / ₂	5 ¹ / ₄ -12	4-12	5 ¹ / ₂	6.249	1	4 ⁵ / ₈	7	5 ³ / ₈	¹ / ₂	1 ¹ / ₂	7	2 ¹ / ₄	3 ⁷ / ₁₆	7 ¹⁵ / ₁₆
	3	2 ¹ / ₂	2 ¹ / ₄ -12	1 ⁷ / ₈ -12	3	3.124	1	2 ¹ / ₁₆	4 ¹ / ₂	2 ³ / ₈	¹ / ₂	1 ¹ / ₂	4	2 ¹ / ₄	3 ⁷ / ₁₆	7 ¹⁵ / ₁₆
	4	3	2 ³ / ₄ -12	2 ¹ / ₄ -12	3 ¹ / ₂	3.749	1	2 ⁵ / ₈	5	2 ⁷ / ₈	¹ / ₂	1 ¹ / ₂	5 ¹ / ₂	2 ¹ / ₄	3 ⁷ / ₁₆	7 ¹⁵ / ₁₆
	5	3 ¹ / ₂	3 ¹ / ₄ -12	2 ¹ / ₂ -12	3 ¹ / ₂	4.249	1	3	5	3 ³ / ₈	¹ / ₂	1 ¹ / ₂	5 ¹ / ₂	2 ¹ / ₄	3 ⁷ / ₁₆	7 ¹⁵ / ₁₆
	6	4	3 ³ / ₄ -12	3-12	4	4.749	1	3 ³ / ₈	5 ¹ / ₂	3 ⁷ / ₈	¹ / ₂	1 ¹ / ₂	5 ¹ / ₂	2 ¹ / ₄	3 ⁷ / ₁₆	7 ¹⁵ / ₁₆
	7	1 ³ / ₈	1 ¹ / ₄ -12	1-14	1 ⁵ / ₈	1.999	⁵ / ₈	1 ¹ / ₈	2 ¹ / ₂	1 ⁵ / ₁₆	¹ / ₄	⁷ / ₈	4	1 ⁵ / ₈	2 ¹³ / ₁₆	7 ⁵ / ₁₆
	8	1 ³ / ₄	1 ¹ / ₂ -12	1 ¹ / ₄ -12	2	2.374	³ / ₄	1 ¹ / ₂	3 ¹ / ₈	1 ¹¹ / ₁₆	³ / ₈	1 ¹ / ₈	4	1 ⁷ / ₈	3 ¹ / ₁₆	7 ⁹ / ₁₆
	9	4 ¹ / ₂	4 ¹ / ₄ -12	3 ¹ / ₄ -12	4 ¹ / ₂	5.249	1	3 ⁷ / ₈	6	4 ³ / ₈	¹ / ₂	1 ¹ / ₂	7	2 ¹ / ₄	3 ⁷ / ₁₆	7 ¹⁵ / ₁₆
	0	5	4 ³ / ₄ -12	3 ¹ / ₂ -12	5	5.749	1	4 ¹ / ₄	6 ¹ / ₂	4 ⁷ / ₈	¹ / ₂	1 ¹ / ₂	7	2 ¹ / ₄	3 ⁷ / ₁₆	7 ¹⁵ / ₁₆

Table 3 — Envelope and Mounting Dimensions

Table 1—Envelope and Mounting Dimensions—Styles JB and HB

Bore	E	EB	EE		F	G	J	K	TE	Add Stroke	
			NPTF ^o	SAE*						LB	P
8	8 ¹ / ₂	1 ¹ / ₁₆	³ / ₄	12	³ / ₄	2	1 ¹ / ₂	⁹ / ₁₆	7.57	5 ⁷ / ₈	3 ¹ / ₄

^o NPTF ports will be furnished as standard unless SAE straight thread ports are specified.
* SAE straight thread ports are indicated by port number.

Table 2—Rod Dimensions—Styles JB and HB

Bore	Rod No.	Rod Dia. MM	Thread		Rod Extensions and Pilot Dimensions								TT	WF	Y	Add Stroke		
			Style 8 CC	Style 4 & 9 KK	A	+0.000 -.002 B	C	D	LA	NA	V	W				XK	ZB	ZJ
8	1(Std.)	2	1 ³ / ₄ -12	1 ¹ / ₂ -12	2 ¹ / ₄	2.624	⁷ / ₈	1 ¹¹ / ₁₆	3 ¹ / ₂	1 ⁵ / ₁₆	³ / ₈	1 ¹ / ₄	4	2	3 ³ / ₁₆	5 ⁵ / ₈	7 ¹¹ / ₁₆	7 ¹ / ₈
	2	5 ¹ / ₂	5 ¹ / ₄ -12	4-12	5 ¹ / ₂	6.249	1	4 ⁵ / ₈	7	5 ³ / ₈	¹ / ₂	1 ¹ / ₂	7	2 ¹ / ₄	3 ⁷ / ₁₆	5 ⁷ / ₈	7 ¹⁵ / ₁₆	7 ³ / ₈
	3	2 ¹ / ₂	2 ¹ / ₄ -12	1 ⁷ / ₈ -12	3	3.124	1	2 ¹ / ₁₆	4 ¹ / ₂	2 ³ / ₈	¹ / ₂	1 ¹ / ₂	4	2 ¹ / ₄	3 ⁷ / ₁₆	5 ⁷ / ₈	7 ¹⁵ / ₁₆	7 ³ / ₈
	4	3	2 ³ / ₄ -12	2 ¹ / ₄ -12	3 ¹ / ₂	3.749	1	2 ⁵ / ₈	5	2 ⁷ / ₈	¹ / ₂	1 ¹ / ₂	5 ¹ / ₂	2 ¹ / ₄	3 ⁷ / ₁₆	5 ⁷ / ₈	7 ¹⁵ / ₁₆	7 ³ / ₈
	5	3 ¹ / ₂	3 ¹ / ₄ -12	2 ¹ / ₂ -12	3 ¹ / ₂	4.249	1	3	5	3 ³ / ₈	¹ / ₂	1 ¹ / ₂	5 ¹ / ₂	2 ¹ / ₄	3 ⁷ / ₁₆	5 ⁷ / ₈	7 ¹⁵ / ₁₆	7 ³ / ₈
	6	4	3 ³ / ₄ -12	3-12	4	4.749	1	3 ³ / ₈	5 ¹ / ₂	3 ⁷ / ₈	¹ / ₂	1 ¹ / ₂	5 ¹ / ₂	2 ¹ / ₄	3 ⁷ / ₁₆	5 ⁷ / ₈	7 ¹⁵ / ₁₆	7 ³ / ₈
	7	1 ³ / ₈	1 ¹ / ₄ -12	1-14	1 ⁵ / ₈	1.999	⁵ / ₈	1 ¹ / ₈	2 ¹ / ₂	1 ⁵ / ₁₆	¹ / ₄	⁷ / ₈	4	1 ⁵ / ₈	2 ¹³ / ₁₆	5 ¹ / ₄	7 ⁵ / ₁₆	6 ³ / ₄
	8	1 ³ / ₄	1 ¹ / ₂ -12	1 ¹ / ₄ -12	2	2.374	³ / ₄	1 ¹ / ₂	3 ¹ / ₈	1 ¹¹ / ₁₆	³ / ₈	1 ¹ / ₈	4	1 ⁷ / ₈	3 ¹ / ₁₆	5 ¹ / ₂	7 ⁹ / ₁₆	7
	9	4 ¹ / ₂	4 ¹ / ₄ -12	3 ¹ / ₄ -12	4 ¹ / ₂	5.249	1	3 ⁷ / ₈	6	4 ³ / ₈	¹ / ₂	1 ¹ / ₂	7	2 ¹ / ₄	3 ⁷ / ₁₆	5 ⁷ / ₈	7 ¹⁵ / ₁₆	7 ³ / ₈
	0	5	4 ³ / ₄ -12	3 ¹ / ₂ -12	5	5.749	1	4 ¹ / ₄	6 ¹ / ₂	4 ⁷ / ₈	¹ / ₂	1 ¹ / ₂	7	2 ¹ / ₄	3 ⁷ / ₁₆	5 ⁷ / ₈	7 ¹⁵ / ₁₆	7 ³ / ₈

For Cylinder Division Plant Locations – See Page II.

**Side Lugs and Centerline Lugs Mountings
8" Bore Size**

**Series 3L
Medium Duty Hydraulic Cylinders**

**Side Lugs
Style C
(NFPA Style MS2)**

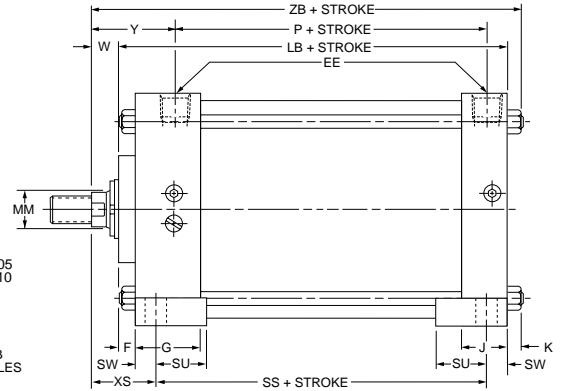
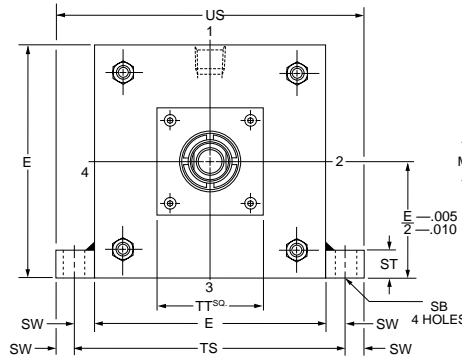
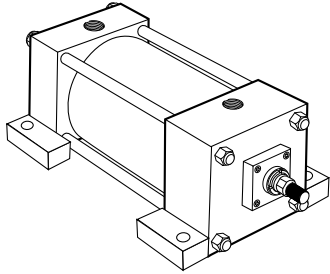

**Centerline Lugs
Style E
(NFPA Style MS3)**

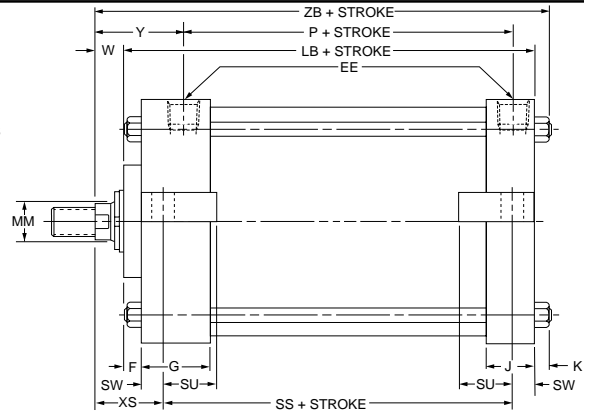
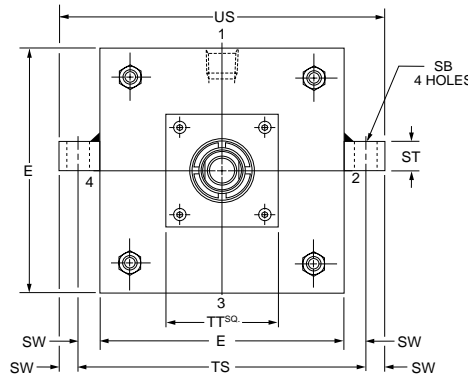
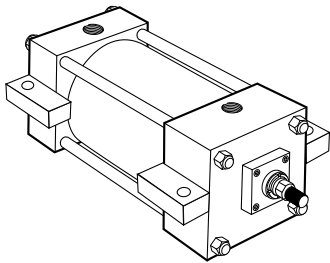

**Side Tapped
Style F
(NFPA Style MS4)**

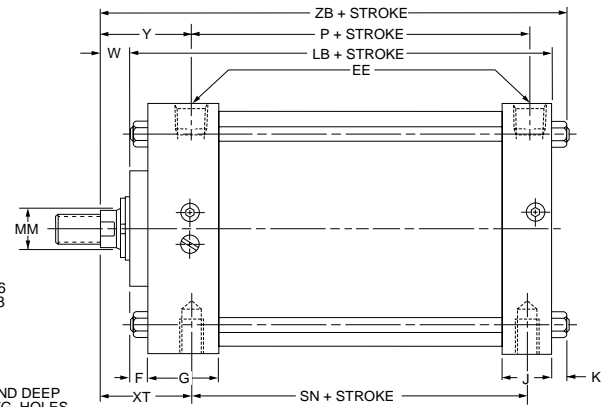
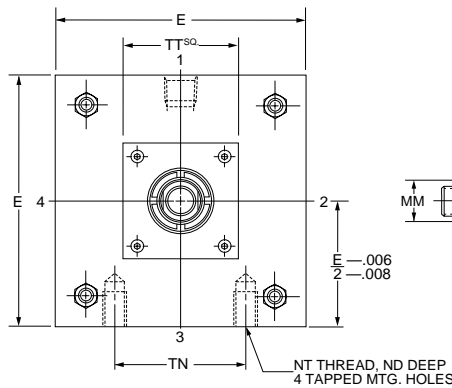
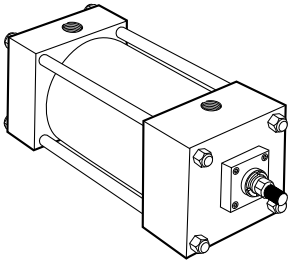

Rod End Dimensions — see tables 2 and 5

**Thread Style 4
(NFPA Style SM)
Small Male**

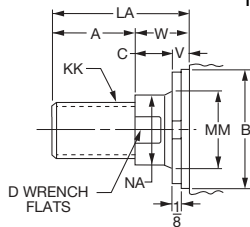

**Thread Style 8
(NFPA Style IM)
Intermediate Male**

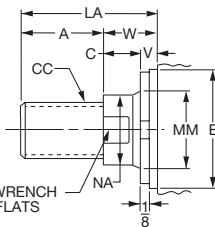

**Thread Style 9
(NFPA Style SF)
Small Female**

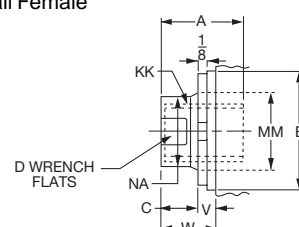

“Special” Thread Style 3

Special thread, extension, rod eye, blank, etc., are also available. To order, specify “Style 3” and give desired dimensions for CC or KK, A and LA. If otherwise special, furnish dimensional sketch.

A high strength rod end stud is supplied on thread style 4 through 2" diameter rods and on thread style 8 through 1 3/8" diameter rods. Larger sizes or special rod ends are cut threads. Style 4 rod ends are recommended where the workpiece is secured against the rod shoulder. When the workpiece is

not shouldered, style 4 rod ends are recommended through 2" piston rod diameters and style 8 rod ends are recommended on larger diameters. Use style 9 for applications where female rod end threads are required. If rod end is not specified, style 4 will be supplied.

For additional information – call your local Parker Cylinder Distributor.

Series 3L Medium Duty Hydraulic Cylinders

Side Lugs and
Centerline Lugs Mountings
8" Bore Size

Table 1—Envelope and Mounting Dimensions—Styles C and E

Bore	E	EE		F	G	J	K	SB*	ST	SU	SW	TS	US	Add Stroke		
		NPTF ^o	SAE*											LB	P	SS
8	8 ¹ / ₂	³ / ₄	12	³ / ₄	2	1 ¹ / ₂	⁹ / ₁₆	¹³ / ₁₆	1	1 ⁹ / ₁₆	¹¹ / ₁₆	9 ⁷ / ₈	11 ¹ / ₄	5 ⁷ / ₈	3 ¹ / ₄	3 ³ / ₄

^o NPTF ports will be furnished as standard unless SAE straight thread ports are specified.

* SAE straight thread ports are indicated by port number.

* Upper surface spot-faced for socket-head screws.

Table 2—Rod Dimensions—Styles C and E

Bore	Rod No.	Rod Dia. MM	Thread		Rod Extensions and Pilot Dimensions								TT	XS	Y	Add Stroke ZB
			Style 8 CC	Style 4 & 9 KK	A	+0.000 -0.002 B	C	D	LA	NA	V	W				
8	1(Std.)	2	1 ³ / ₄ -12	1 ¹ / ₂ -12	2 ¹ / ₄	2.624	⁷ / ₈	1 ¹¹ / ₁₆	3 ¹ / ₂	1 ¹⁵ / ₁₆	³ / ₈	1 ¹ / ₄	4	2 ¹¹ / ₁₆	3 ³ / ₁₆	7 ¹¹ / ₁₆
	2	5 ¹ / ₂	5 ¹ / ₄ -12	4-12	5 ¹ / ₂	6.249	1	4 ⁵ / ₈	7	5 ³ / ₈	¹ / ₂	1 ¹ / ₂	7	2 ¹⁵ / ₁₆	3 ⁷ / ₁₆	7 ¹⁵ / ₁₆
	3	2 ¹ / ₂	2 ¹ / ₄ -12	1 ⁷ / ₈ -12	3	3.124	1	2 ¹ / ₁₆	4 ¹ / ₂	2 ³ / ₈	¹ / ₂	1 ¹ / ₂	4	2 ¹⁵ / ₁₆	3 ⁷ / ₁₆	7 ¹⁵ / ₁₆
	4	3	2 ³ / ₄ -12	2 ¹ / ₄ -12	3 ¹ / ₂	3.749	1	2 ⁵ / ₈	5	2 ⁷ / ₈	¹ / ₂	1 ¹ / ₂	5 ¹ / ₂	2 ¹⁵ / ₁₆	3 ⁷ / ₁₆	7 ¹⁵ / ₁₆
	5	3 ¹ / ₂	3 ¹ / ₄ -12	2 ¹ / ₂ -12	3 ¹ / ₂	4.249	1	3	5	3 ³ / ₈	¹ / ₂	1 ¹ / ₂	5 ¹ / ₂	2 ¹⁵ / ₁₆	3 ⁷ / ₁₆	7 ¹⁵ / ₁₆
	6	4	3 ³ / ₄ -12	3-12	4	4.749	1	3 ³ / ₈	5 ¹ / ₂	3 ⁷ / ₈	¹ / ₂	1 ¹ / ₂	5 ¹ / ₂	2 ¹⁵ / ₁₆	3 ⁷ / ₁₆	7 ¹⁵ / ₁₆
	7	1 ³ / ₈	1 ¹ / ₄ -12	1-14	1 ⁵ / ₈	1.999	⁵ / ₈	1 ¹ / ₈	2 ¹ / ₂	1 ⁵ / ₁₆	¹ / ₄	⁷ / ₈	4	2 ⁵ / ₁₆	2 ¹³ / ₁₆	7 ⁵ / ₁₆
	8	1 ³ / ₄	1 ¹ / ₂ -12	1 ¹ / ₄ -12	2	2.374	³ / ₄	1 ¹ / ₂	3 ¹ / ₈	1 ¹¹ / ₁₆	³ / ₈	1 ¹ / ₈	4	2 ⁹ / ₁₆	3 ¹ / ₁₆	7 ⁹ / ₁₆
	9	4 ¹ / ₂	4 ¹ / ₄ -12	3 ¹ / ₄ -12	4 ¹ / ₂	5.249	1	3 ⁷ / ₈	6	4 ³ / ₈	¹ / ₂	1 ¹ / ₂	7	2 ¹⁵ / ₁₆	3 ⁷ / ₁₆	7 ¹⁵ / ₁₆
0	5	4 ³ / ₄ -12	3 ¹ / ₂ -12	5	5.749	1	4 ¹ / ₄	6 ¹ / ₂	4 ⁷ / ₈	¹ / ₂	1 ¹ / ₂	7	2 ¹⁵ / ₁₆	3 ⁷ / ₁₆	7 ¹⁵ / ₁₆	

Table 3 — Envelope and Mounting Dimensions

Table 4—Envelope and Mounting Dimensions—Style F

Bore	E	EE		F	G	J	K	ND	NT	TN	Add Stroke		
		NPTF ^o	SAE*								LB	P	SN
8	8 ¹ / ₂	³ / ₄	12	³ / ₄	2	1 ¹ / ₂	⁹ / ₁₆	1 ¹ / ₈	³ / ₄ -10	4 ¹ / ₂	5 ⁷ / ₈	3 ¹ / ₄	3 ¹ / ₄

^o NPTF ports will be furnished as standard unless SAE straight thread ports are specified.

* SAE straight thread ports are indicated by port number.

Table 5—Rod Dimensions—Style F

Bore	Rod No.	Rod Dia. MM	Thread		Rod Extensions and Pilot Dimensions								TT	XT	Y	Add Stroke ZB
			Style 8 CC	Style 4 & 9 KK	A	+0.000 -0.002 B	C	D	LA	NA	V	W				
8	1(Std.)	2	1 ³ / ₄ -12	1 ¹ / ₂ -12	2 ¹ / ₄	2.624	⁷ / ₈	1 ¹¹ / ₁₆	3 ¹ / ₂	1 ⁵ / ₁₆	³ / ₈	1 ¹ / ₄	4	3 ³ / ₁₆	3 ³ / ₁₆	7 ¹¹ / ₁₆
	2	5 ¹ / ₂	5 ¹ / ₄ -12	4-12	5 ¹ / ₂	6.249	1	4 ⁵ / ₈	7	5 ³ / ₈	¹ / ₂	1 ¹ / ₂	7	3 ⁷ / ₁₆	3 ⁷ / ₁₆	7 ¹⁵ / ₁₆
	3	2 ¹ / ₂	2 ¹ / ₄ -12	1 ⁷ / ₈ -12	3	3.124	1	2 ¹ / ₁₆	4 ¹ / ₂	2 ³ / ₈	¹ / ₂	1 ¹ / ₂	4	3 ⁷ / ₁₆	3 ⁷ / ₁₆	7 ¹⁵ / ₁₆
	4	3	2 ³ / ₄ -12	2 ¹ / ₄ -12	3 ¹ / ₂	3.749	1	2 ⁵ / ₈	5	2 ⁷ / ₈	¹ / ₂	1 ¹ / ₂	5 ¹ / ₂	3 ⁷ / ₁₆	3 ⁷ / ₁₆	7 ¹⁵ / ₁₆
	5	3 ¹ / ₂	3 ¹ / ₄ -12	2 ¹ / ₂ -12	3 ¹ / ₂	4.249	1	3	5	3 ³ / ₈	¹ / ₂	1 ¹ / ₂	5 ¹ / ₂	3 ⁷ / ₁₆	3 ⁷ / ₁₆	7 ¹⁵ / ₁₆
	6	4	3 ³ / ₄ -12	3-12	4	4.749	1	3 ³ / ₈	5 ¹ / ₂	3 ⁷ / ₈	¹ / ₂	1 ¹ / ₂	5 ¹ / ₂	3 ⁷ / ₁₆	3 ⁷ / ₁₆	7 ¹⁵ / ₁₆
	7	1 ³ / ₈	1 ¹ / ₄ -12	1-14	1 ⁵ / ₈	1.999	⁵ / ₈	1 ¹ / ₈	2 ¹ / ₂	1 ⁵ / ₁₆	¹ / ₄	⁷ / ₈	4	2 ¹³ / ₁₆	2 ¹³ / ₁₆	7 ⁵ / ₁₆
	8	1 ³ / ₄	1 ¹ / ₂ -12	1 ¹ / ₄ -12	2	2.374	³ / ₄	1 ¹ / ₂	3 ¹ / ₈	1 ¹¹ / ₁₆	³ / ₈	1 ¹ / ₈	4	3 ¹ / ₁₆	3 ¹ / ₁₆	7 ⁹ / ₁₆
	9	4 ¹ / ₂	4 ¹ / ₄ -12	3 ¹ / ₄ -12	4 ¹ / ₂	5.249	1	3 ⁷ / ₈	6	4 ³ / ₈	¹ / ₂	1 ¹ / ₂	7	3 ⁷ / ₁₆	3 ⁷ / ₁₆	7 ¹⁵ / ₁₆
0	5	4 ³ / ₄ -12	3 ¹ / ₂ -12	5	5.749	1	4 ¹ / ₄	6 ¹ / ₂	4 ⁷ / ₈	¹ / ₂	1 ¹ / ₂	7	3 ⁷ / ₁₆	3 ⁷ / ₁₆	7 ¹⁵ / ₁₆	

Table 6 — Envelope and Mounting Dimensions

For Cylinder Division Plant Locations – See Page II.

Side End Lugs and Clevis Mountings
8" Bore Size

Series 3L
Medium Duty Hydraulic Cylinders

Side End Lugs
Style G
(NFFA Style MS7)

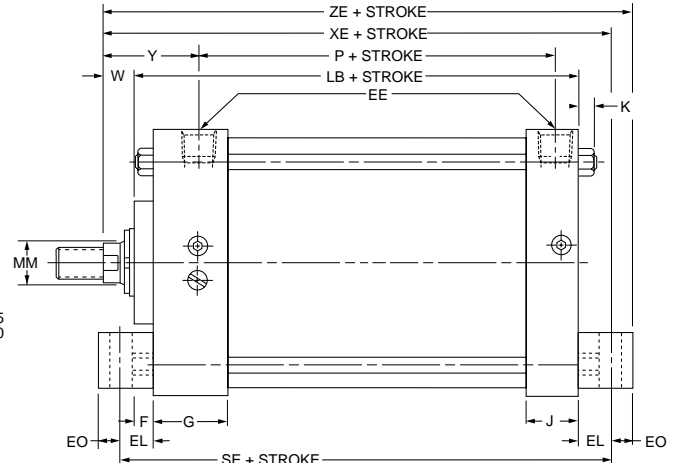
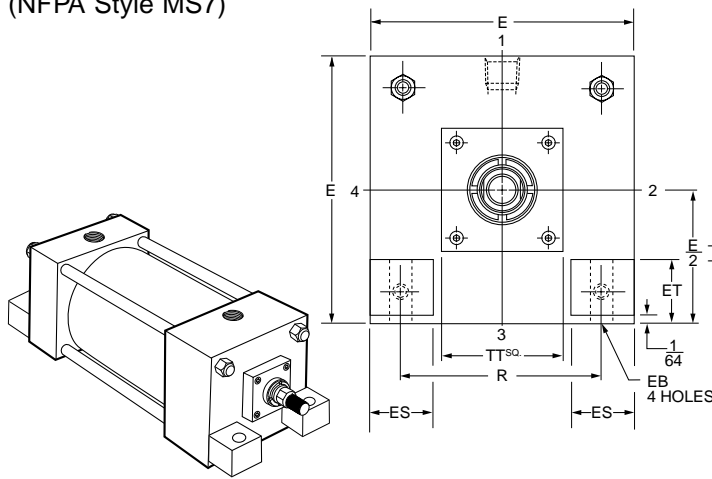

Cylinders with this mounting style are mounted on the precision ground surfaces of the head and cap. There must be a minimum gap of at least 1/64 of an inch between the bottom of the lug and the mounting surface before the mounting bolts are tightened.

This mounting not offered in 8" bore size, rod codes #2, 4, 5, 6, 9, and 0.

Cap Fixed Clevis
Style BB
(NFFA Style MP1)

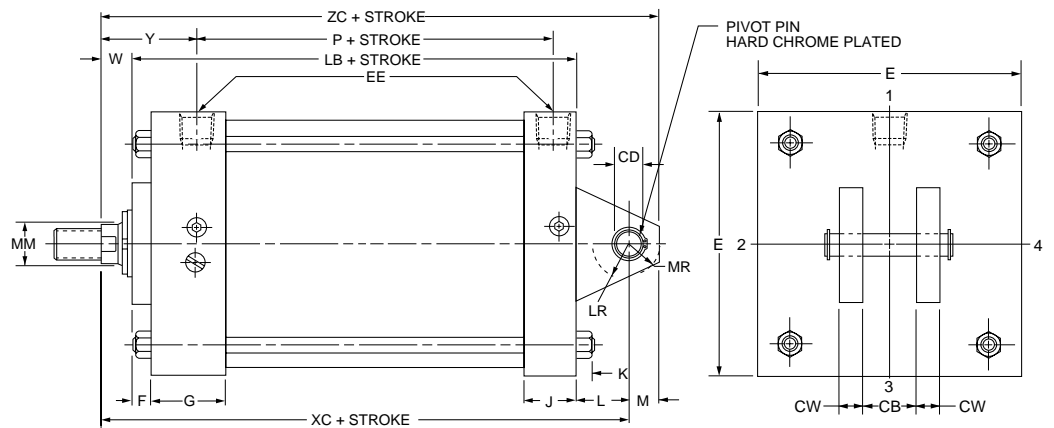
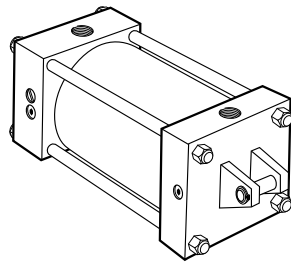

Rod End Dimensions — see tables 2 and 5

Thread Style 4
(NFFA Style SM)
Small Male

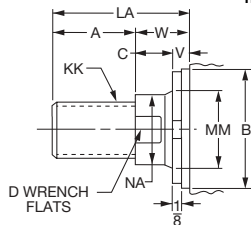

Thread Style 8
(NFFA Style IM)
Intermediate Male

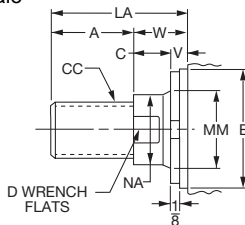

Thread Style 9
(NFFA Style SF)
Small Female

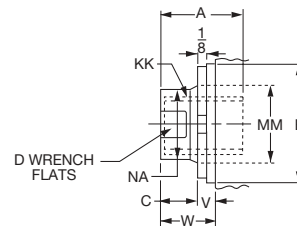

A high strength rod end stud is supplied on thread style 4 through 2" diameter rods and on thread style 8 through 1 3/8" diameter rods. Larger sizes or special rod ends are cut threads. Style 4 rod ends are recommended where the workpiece is secured against the rod shoulder. When the workpiece is

not shouldered, style 4 rod ends are recommended through 2" piston rod diameters and style 8 rod ends are recommended on larger diameters. Use style 9 for applications where female rod end threads are required. If rod end is not specified, style 4 will be supplied.

"Special" Thread Style 3

Special thread, extension, rod eye, blank, etc., are also available. To order, specify "Style 3" and give desired dimensions for CC or KK, A and LA. If otherwise special, furnish dimensional sketch.

For additional information – call your local Parker Cylinder Distributor.

Series 3L Medium Duty Hydraulic Cylinders

Side End Lugs and
Clevis Mountings
8" Bore Size

Table 1—Envelope and Mounting Dimensions—Style G

Bore	E	EB	EE		EL	EO	ES	ET	F	G	J	K	NT	R	Add Stroke		
			NPTF ^o	SAE*											LB	P	SE
8	8 ¹ / ₂	1 ¹ / ₁₆	3 ³ / ₄	12	1 ¹ / ₈	5 ⁵ / ₈	2 ¹ / ₄	1 ¹⁵ / ₁₆	3 ³ / ₄	2	1 ¹ / ₂	9 ⁹ / ₁₆	3 ³ / ₄ -10	6.44	5 ⁷ / ₈	3 ³ / ₄	7 ⁷ / ₈

^o NPTF ports will be furnished as standard unless SAE straight thread ports are specified.

* SAE straight thread ports are indicated by port number.

Table 2—Rod Dimensions—Style G

Bore	Rod No.	Rod Dia. MM	Thread		Rod Extensions and Pilot Dimensions								Add Stroke			
			Style 8 CC	Style 4 & 9 KK	A	+0.000 -0.002 B	C	D	LA	NA	V	W	TT	Y	XE	ZE
8	1 (Std.)	2	1 ³ / ₄ -12	1 ¹ / ₂ -12	2 ¹ / ₄	2.624	7 ⁷ / ₈	1 ¹¹ / ₁₆	3 ³ / ₂	1 ¹⁵ / ₁₆	3 ³ / ₈	1 ¹ / ₄	4	3 ³ / ₁₆	8 ¹ / ₄	8 ⁷ / ₈
	2	5 ¹ / ₂	5 ¹ / ₄ -12	4-12	5 ¹ / ₂	6.249	1	4 ⁵ / ₈	7	5 ³ / ₈	1 ¹ / ₂	1 ¹ / ₂	*	*	*	*
	3	2 ¹ / ₂	2 ¹ / ₄ -12	1 ⁷ / ₈ -12	3	3.124	1	2 ¹ / ₁₆	4 ¹ / ₂	2 ³ / ₈	1 ¹ / ₂	1 ¹ / ₂	4	3 ⁷ / ₁₆	8 ¹ / ₂	9 ¹ / ₈
	4	3	2 ³ / ₄ -12	2 ¹ / ₄ -12	3 ¹ / ₂	3.749	1	2 ⁵ / ₈	5	2 ⁷ / ₈	1 ¹ / ₂	1 ¹ / ₂	*	*	*	*
	5	3 ¹ / ₂	3 ¹ / ₄ -12	2 ¹ / ₂ -12	3 ¹ / ₂	4.249	1	3	5	3 ³ / ₈	1 ¹ / ₂	1 ¹ / ₂	*	*	*	*
	6	4	3 ³ / ₄ -12	3-12	4	4.749	1	3 ³ / ₈	5 ¹ / ₂	3 ⁷ / ₈	1 ¹ / ₂	1 ¹ / ₂	*	*	*	*
	7	1 ³ / ₈	1 ¹ / ₄ -12	1-14	1 ⁵ / ₈	1.999	5 ⁵ / ₈	1 ¹ / ₈	2 ¹ / ₂	1 ⁵ / ₁₆	1 ¹ / ₄	7 ⁷ / ₈	4	2 ¹³ / ₁₆	7 ⁷ / ₈	8 ¹ / ₂
	8	1 ³ / ₄	1 ¹ / ₂ -12	1 ¹ / ₄ -12	2	2.374	3 ³ / ₄	1 ¹ / ₂	3 ¹ / ₈	1 ¹¹ / ₁₆	3 ³ / ₈	1 ¹ / ₈	4	3 ¹ / ₁₆	8 ¹ / ₈	8 ³ / ₄
	9	4 ¹ / ₂	4 ¹ / ₄ -12	3 ¹ / ₄ -12	4 ¹ / ₂	5.249	1	3 ⁷ / ₈	6	4 ³ / ₈	1 ¹ / ₂	1 ¹ / ₂	7	3 ⁷ / ₁₆	*	*
0	5	4 ³ / ₄ -12	3 ¹ / ₂ -12	5	5.749	1	4 ¹ / ₄	6 ¹ / ₂	4 ⁷ / ₈	1 ¹ / ₂	1 ¹ / ₂	*	*	*	*	

* Mounting style G not offered in this rod size.

Caution: When using mounting style G, check clearance between mounting members and rod attachment or accessory. If necessary, specify longer rod extension to avoid interference with mounting members.

Table 3 — Envelope and Mounting Dimensions

Table 4—Envelope and Mounting Dimensions—Style BB

Bore	CB	+0.000 -0.002 CD*	CW	E	EE		F	G	J	K	L	LR	M	Add Stroke		
					NPTF ^o	SAE*								MR	LB	P
8	1 ¹ / ₂	1.001	3 ³ / ₄	8 ¹ / ₂	3 ³ / ₄	12	3 ³ / ₄	2	1 ¹ / ₂	9 ⁹ / ₁₆	1 ¹ / ₂	1 ¹ / ₄	1	1 ¹ / ₁₆	5 ⁷ / ₈	3 ³ / ₄

^o NPTF ports will be furnished as standard unless SAE straight thread ports are specified.

* SAE straight thread ports are indicated by port number.

* Dimension CD is pin diameter.

Table 5—Rod Dimensions—Style BB

Bore	Rod No.	Rod Dia. MM	Thread		Rod Extensions and Pilot Dimensions								Add Stroke		
			Style 8 CC	Style 4 & 9 KK	A	+0.000 -0.002 B	C	D	LA	NA	V	W	Y	XC	ZC
8	1 (Std.)	2	1 ³ / ₄ -12	1 ¹ / ₂ -12	2 ¹ / ₄	2.624	7 ⁷ / ₈	1 ¹¹ / ₁₆	3 ³ / ₂	1 ¹⁵ / ₁₆	3 ³ / ₈	1 ¹ / ₄	3 ³ / ₁₆	8 ⁵ / ₈	9 ⁵ / ₈
	2	5 ¹ / ₂	5 ¹ / ₄ -12	4-12	5 ¹ / ₂	6.249	1	4 ⁵ / ₈	7	5 ³ / ₈	1 ¹ / ₂	1 ¹ / ₂	3 ⁷ / ₁₆	8 ⁷ / ₈	9 ⁷ / ₈
	3	2 ¹ / ₂	2 ¹ / ₄ -12	1 ⁷ / ₈ -12	3	3.124	1	2 ¹ / ₁₆	4 ¹ / ₂	2 ³ / ₈	1 ¹ / ₂	1 ¹ / ₂	3 ⁷ / ₁₆	8 ⁷ / ₈	9 ⁷ / ₈
	4	3	2 ³ / ₄ -12	2 ¹ / ₄ -12	3 ¹ / ₂	3.749	1	2 ⁵ / ₈	5	2 ⁷ / ₈	1 ¹ / ₂	1 ¹ / ₂	3 ⁷ / ₁₆	8 ⁷ / ₈	9 ⁷ / ₈
	5	3 ¹ / ₂	3 ¹ / ₄ -12	2 ¹ / ₂ -12	3 ¹ / ₂	4.249	1	3	5	3 ³ / ₈	1 ¹ / ₂	1 ¹ / ₂	3 ⁷ / ₁₆	8 ⁷ / ₈	9 ⁷ / ₈
	6	4	3 ³ / ₄ -12	3-12	4	4.749	1	3 ³ / ₈	5 ¹ / ₂	3 ⁷ / ₈	1 ¹ / ₂	1 ¹ / ₂	3 ⁷ / ₁₆	8 ⁷ / ₈	9 ⁷ / ₈
	7	1 ³ / ₈	1 ¹ / ₄ -12	1-14	1 ⁵ / ₈	1.999	5 ⁵ / ₈	1 ¹ / ₈	2 ¹ / ₂	1 ⁵ / ₁₆	1 ¹ / ₄	7 ⁷ / ₈	2 ¹³ / ₁₆	8 ¹ / ₄	9 ¹ / ₄
	8	1 ³ / ₄	1 ¹ / ₂ -12	1 ¹ / ₄ -12	2	2.374	3 ³ / ₄	1 ¹ / ₂	3 ¹ / ₈	1 ¹¹ / ₁₆	3 ³ / ₈	1 ¹ / ₈	3 ¹ / ₁₆	8 ¹ / ₂	9 ¹ / ₂
	9	4 ¹ / ₂	4 ¹ / ₄ -12	3 ¹ / ₄ -12	4 ¹ / ₂	5.249	1	3 ⁷ / ₈	6	4 ³ / ₈	1 ¹ / ₂	1 ¹ / ₂	3 ⁷ / ₁₆	8 ⁷ / ₈	9 ⁷ / ₈
0	5	4 ³ / ₄ -12	3 ¹ / ₂ -12	5	5.749	1	4 ¹ / ₄	6 ¹ / ₂	4 ⁷ / ₈	1 ¹ / ₂	1 ¹ / ₂	3 ⁷ / ₁₆	8 ⁷ / ₈	9 ⁷ / ₈	

Table 6 — Envelope and Mounting Dimensions

For Cylinder Division Plant Locations – See Page II.

**Trunnion Mountings
8" Bore Size**

Series 3L Medium Duty Hydraulic Cylinders

**Head Trunnion
Style D
(NFFA Style MT1)**

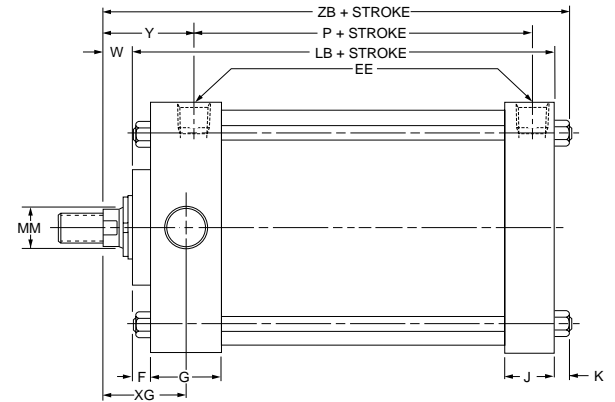
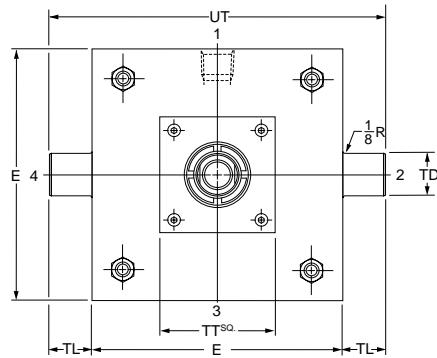
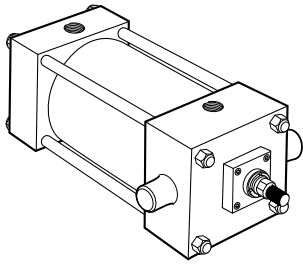

**Cap Trunnion
Style DB
(NFFA Style MT2)**

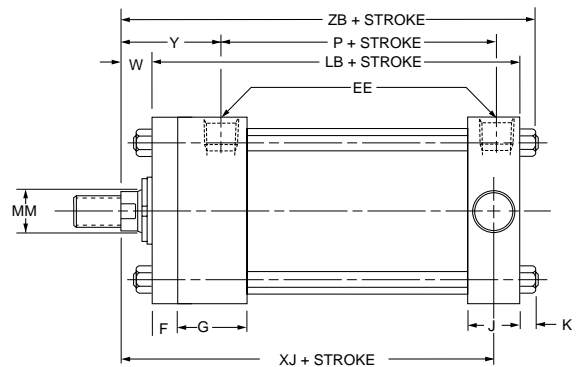
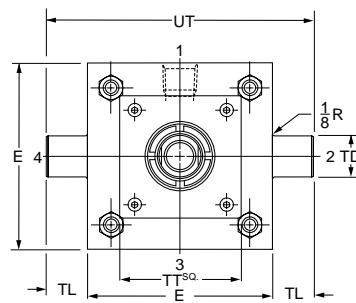
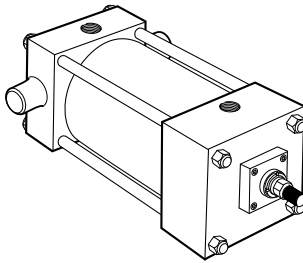

**Intermediate Fixed Trunnion
Style DD
(NFFA Style MT4)**

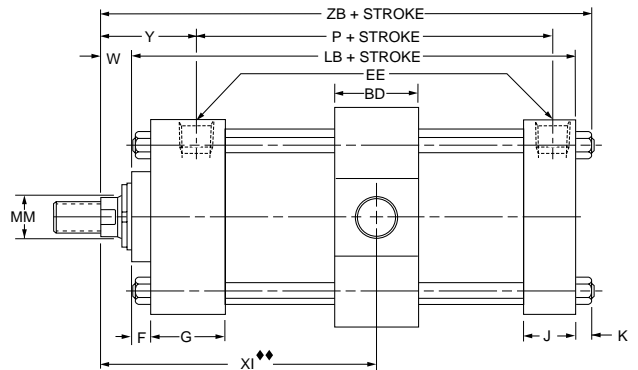
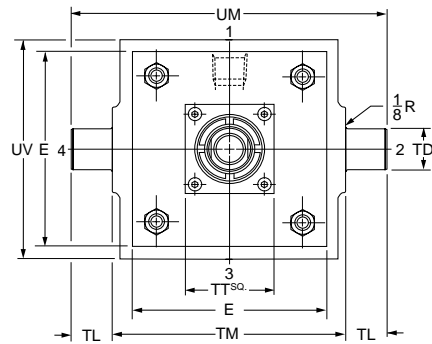
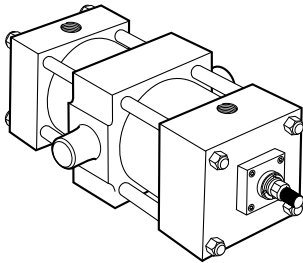

Rod End Dimensions — see tables 2 and 5

**Thread Style 4
(NFFA Style SM)
Small Male**

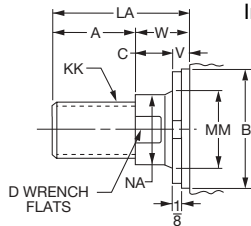

**Thread Style 8
(NFFA Style IM)
Intermediate Male**

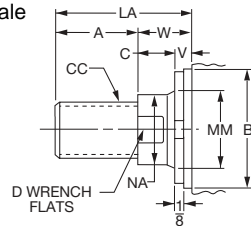

**Thread Style 9
(NFFA Style SF)
Small Female**

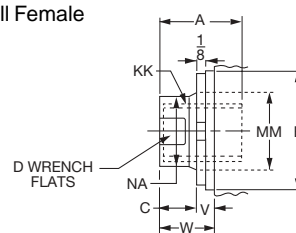

Special Thread Style 3
Special thread, extension, rod eye, blank, etc., are also available. To order, specify "Style 3" and give desired dimensions for CC or KK, A and LA. If otherwise special, furnish dimensional sketch.

A high strength rod end stud is supplied on thread style 4 through 2" diameter rods and on thread style 8 through 1 3/8" diameter rods. Larger sizes or special rod ends are cut threads. Style 4 rod ends are recommended where the workpiece is secured against the rod shoulder. When the workpiece is

not shouldered, style 4 rod ends are recommended through 2" piston rod diameters and style 8 rod ends are recommended on larger diameters. Use style 9 for applications where female rod end threads are required. If rod end is not specified, style 4 will be supplied.

For additional information – call your local Parker Cylinder Distributor.

Series 3L Medium Duty Hydraulic Cylinders

Trunnion Mountings
8" Bore Size

Table 1—Envelope and Mounting Dimensions—Styles D and DB

Bore	E	EE		F	G	J	K	+0.000 -0.001 TD	TL	UT	Add Stroke	
		NPTF ^o	SAE*								LB	P
8	8 1/2	3/4	12	3/4	2	1 1/2	9/16	1.375	1 3/8	11 1/4	5 7/8	3 1/4

^o NPTF ports will be furnished as standard unless SAE straight thread ports are specified.
* SAE straight thread ports are indicated by port number.

Table 2—Rod Dimensions—Styles D and DB

Bore	Rod No.	Rod Dia. MM	Thread		Rod Extensions and Pilot Dimensions								Add Stroke				
			Style 8 CC	Style 4 & 9 KK	A	+0.000 -0.002 B	C	D	LA	NA	V	W	TT	XG	Y	XJ	ZB
8	1 (Std.)	2	1 3/4-12	1 1/2-12	2 1/4	2.624	7/8	1 11/16	3 1/2	1 15/16	3/8	1 1/4	4	3	3 3/16	6 3/8	7 11/16
	2	5 1/2	5 1/4-12	4-12	5 1/2	6.249	1	4 5/8	7	5 3/8	1/2	1 1/2	7	3 1/4	3 7/16	6 5/8	7 15/16
	3	2 1/2	2 1/4-12	1 7/8-12	3	3.124	1	2 1/16	4 1/2	2 3/8	1/2	1 1/2	4	3 1/4	3 7/16	6 5/8	7 15/16
	4	3	2 3/4-12	2 1/4-12	3 1/2	3.749	1	2 5/8	5	2 7/8	1/2	1 1/2	5 1/2	3 1/4	3 7/16	6 5/8	7 15/16
	5	3 1/2	3 1/4-12	2 1/2-12	3 1/2	4.249	1	3	5	3 3/8	1/2	1 1/2	5 1/2	3 1/4	3 7/16	6 5/8	7 15/16
	6	4	3 3/4-12	3-12	4	4.749	1	3 3/8	5 1/2	3 7/8	1/2	1 1/2	5 1/2	3 1/4	3 7/16	6 5/8	7 15/16
	7	1 3/8	1 1/4-12	1-14	1 5/8	1.999	5/8	1 1/8	2 1/2	1 5/16	1/4	7/8	4	2 5/8	2 13/16	6	7 5/16
	8	1 3/4	1 1/2-12	1 1/4-12	2	2.374	3/4	1 1/2	3 1/8	1 11/16	3/8	1 1/8	4	2 7/8	3 1/16	6 1/4	7 9/16
	9	4 1/2	4 1/4-12	3 1/4-12	4 1/2	5.249	1	3 7/8	6	4 3/8	1/2	1 1/2	7	3 1/4	3 7/16	6 5/8	7 15/16
	0	5	4 3/4-12	3 1/2-12	5	5.749	1	4 1/4	6 1/2	4 7/8	1/2	1 1/2	7	3 1/4	3 7/16	6 5/8	7 15/16

Table 3—Envelope and Mounting Dimensions

Table 4—Envelope and Mounting Dimensions—Style DD

Bore	BD	E	EE		F	G	J	K	+0.000 -0.001 TD	TL	TM	UM	UV	Add Stroke		Style DD Min. Stroke
			NPTF ^o	SAE*										LB	P	
8	2 1/2	8 1/2	3/4	12	3/4	2	1 1/2	9/16	1.375	1 3/8	9 3/4	12 1/2	9 1/2	5 7/8	3 1/4	7/8

^o NPTF ports will be furnished as standard unless SAE straight thread ports are specified.
* SAE straight thread ports are indicated by port number.

Table 5—Rod Dimensions—Style DD

Bore	Rod No.	Rod Dia. MM	Thread		Rod Extensions and Pilot Dimensions								TT	Min. ♦♦ XI	Y	Add Stroke ZB
			Style 8 CC	Style 4 & 9 KK	A	+0.000 -0.002 B	C	D	LA	NA	V	W				
8	1 (Std.)	2	1 3/4-12	1 1/2-12	2 1/4	2.624	7/8	1 11/16	3 1/2	1 15/16	3/8	1 1/4	4	5 5/16	3 3/16	7 11/16
	2	5 1/2	5 1/4-12	4-12	5 1/2	6.249	1	4 5/8	7	5 3/8	1/2	1 1/2	7	5 9/16	3 7/16	7 15/16
	3	2 1/2	2 1/4-12	1 7/8-12	3	3.124	1	2 1/16	4 1/2	2 3/8	1/2	1 1/2	4	5 9/16	3 7/16	7 15/16
	4	3	2 3/4-12	2 1/4-12	3 1/2	3.749	1	2 5/8	5	2 7/8	1/2	1 1/2	5 1/2	5 9/16	3 7/16	7 15/16
	5	3 1/2	3 1/4-12	2 1/2-12	3 1/2	4.249	1	3	5	3 3/8	1/2	1 1/2	5 1/2	5 9/16	3 7/16	7 15/16
	6	4	3 3/4-12	3-12	4	4.749	1	3 3/8	5 1/2	3 7/8	1/2	1 1/2	5 1/2	5 9/16	3 7/16	7 15/16
	7	1 3/8	1 1/4-12	1-14	1 5/8	1.999	5/8	1 1/8	2 1/2	1 5/16	1/4	7/8	4	4 15/16	2 13/16	7 5/16
	8	1 3/4	1 1/2-12	1 1/4-12	2	2.374	3/4	1 1/2	3 1/8	1 11/16	3/8	1 1/8	4	5 3/16	3 1/16	7 9/16
	9	4 1/2	4 1/4-12	3 1/4-12	4 1/2	5.249	1	3 7/8	6	4 3/8	1/2	1 1/2	7	5 9/16	3 7/16	7 15/16
	0	5	4 3/4-12	3 1/2-12	5	5.749	1	4 1/4	6 1/2	4 7/8	1/2	1 1/2	7	5 9/16	3 7/16	7 15/16

♦♦ Dimension XI to be specified by customer.

Table 6—Envelope and Mounting Dimensions

For Cylinder Division Plant Locations – See Page II.

**Spherical Bearing Mounting
Style SB
1½" to 6" Bore Sizes**

**Series 3L
Medium Duty Hydraulic Cylinders**

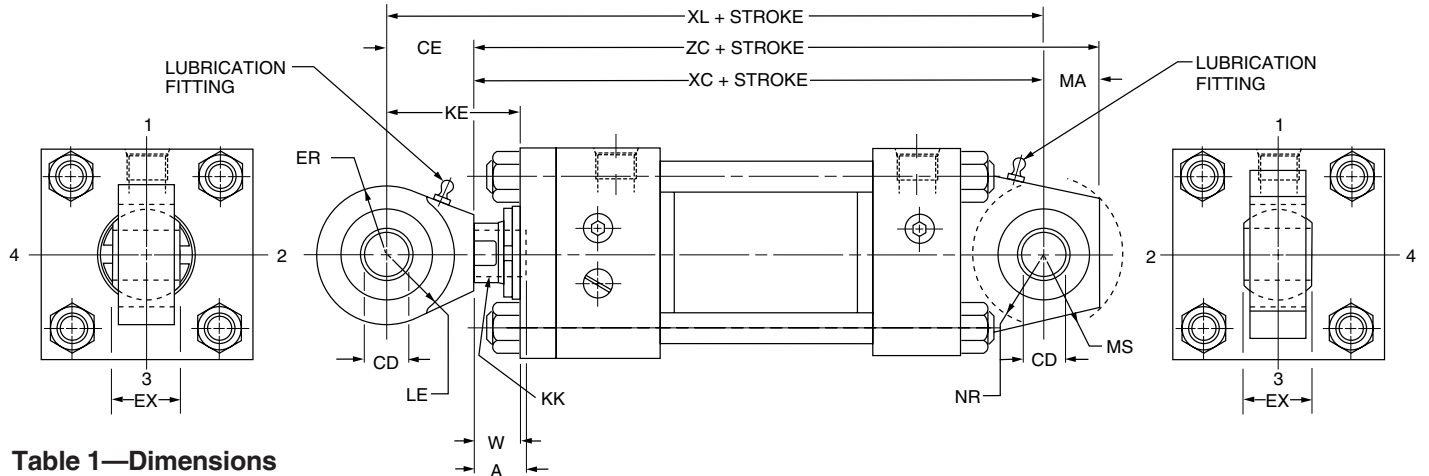

Table 1—Dimensions

Bore	Rod No. 3L	Rod Dia.	Rod End Thread		A	W	Add Stroke			KE	CD*	CE	ER	EX	LE	MA	MS	NR	Max. Oper. PSI	
			Style 9 KK	Style 7 KK			XC	XL	ZC										2A	3L†
1½	1(Std.)	5/8	7/16-20	—	3/4	5/8	5 3/8	6 1/4	6 1/8	1 1/2	-.0005	7/8	1 3/16	7/16	3/4	3/4	1 5/16	5/8	250	1500
	2	1	—	7/16-20	3/4	1	5 3/4	6 5/8	6 1/2	1 7/8	.5000									
2	1(Std.)	5/8	7/16-20	—	3/4	5/8	5 3/8	6 1/4	6 1/8	1 1/2	-.0005	7/8	1 3/16	7/16	3/4	3/4	1 5/16	5/8	250	980
	2	1 3/8	—	7/16-20	3/4	1 1/4	6	6 7/8	6 3/4	2 1/8	.5000									
	3	1	—	7/16-20	3/4	1	5 3/4	6 5/8	6 1/2	1 7/8										
2½	7	5/8	7/16-20	—	3/4	5/8	5 1/2	6 3/8	6 1/4	1 1/2	-.0005	7/8	1 3/16	7/16	3/4	3/4	1 5/16	5/8	250	630
	2	1 3/4	—	7/16-20	3/4	1 1/2	6 3/8	7 1/4	7 1/8	2 3/8	.5000									
	1(Std.)	1	—	7/16-20	3/4	1	5 7/8	6 3/4	6 5/8	1 7/8										
3¼	3	1 3/8	—	7/16-20	3/4	1 1/4	6 1/8	7	6 7/8	2 1/8										
	1(Std.)	1	3/4-16	—	1 1/8	3/4	6 7/8	8 1/8	7 7/8	2	-.0005	1 1/4	1 1/8	2 1/32	1 1/16	1	1 3/8	1	250	830
	2	2	—	3/4-16	1 1/8	1 3/8	7 1/2	8 3/4	8 1/2	2 5/8	.7500									
4	3	1 3/8	—	3/4-16	1 1/8	1	7 1/8	8 3/8	8 1/8	2 1/4										
	4	1 3/4	—	3/4-16	1 1/8	1 1/4	7 3/8	8 5/8	8 3/8	2 1/2	-.0005	1 1/4	1 1/8	2 1/32	1 1/16	1	1 3/8	1	250	550
	1(Std.)	1 3/8	—	3/4-16	1 1/8	1	7 1/8	8 3/8	8 1/8	2 1/4	.7500									
	2	2	—	3/4-16	1 1/8	1 1/4	7 3/8	8 5/8	8 3/8	2 1/2										
5	7	1	3/4-16	—	1 1/8	3/4	6 7/8	8 1/8	7 7/8	2	-.0005	1 1/4	1 1/8	2 1/32	1 1/16	1	1 3/8	1	250	350
	2	3 1/2	—	3/4-16	1 1/8	1 5/8	8	9 1/4	9	2 7/8	.7500									
	8	1 3/8	—	3/4-16	1 1/8	1	7 3/8	8 5/8	8 3/8	2 1/4										
	1(Std.)	1 3/4	—	3/4-16	1 1/8	1 1/4	7 5/8	8 7/8	8 5/8	2 1/2	-.0005	1 1/4	1 1/8	2 1/32	1 1/16	1	1 3/8	1	250	350
	3	2	—	3/4-16	1 1/8	1 3/8	7 3/4	9	8 3/4	2 5/8	.7500									
	4	2 1/2	—	3/4-16	1 1/8	1 5/8	8	9 1/4	9	2 7/8										
6	5	3	—	3/4-16	1 1/8	1 5/8	8	9 1/4	9	2 7/8										
	7	1 3/8	1-14	—	1 5/8	7/8	8 1/8	10	9 3/8	2 3/4	-.0005	1 7/8	1 1/4	7/8	1 7/16	1 1/4	1 11/16	1 1/4	250	440
	2	4	—	1-14	1 5/8	1 1/2	8 3/4	10 5/8	10	3 3/8	.0000									
	1(Std.)	1 3/4	—	1-14	1 5/8	1 1/8	8 3/8	10 1/4	9 5/8	3	1.0000									
	3	2	—	1-14	1 5/8	1 1/4	8 1/2	10 3/8	9 3/4	3 1/8										
	4	2 1/2	—	1-14	1 5/8	1 1/2	8 3/4	10 5/8	10	3 3/8										

Note: For additional dimensions see Series 3L, Style BB mount.
 * Dimension CD is hole diameter.
 † Maximum operating pressure at 4:1 design factor is based on tensile strength of material.
 Pressure ratings are based on standard commercial bearing ratings.
 Rod No. 1 is standard

For additional information – call your local Parker Cylinder Distributor.

Series 3L Medium Duty Hydraulic Cylinders

Spherical Bearing Mounting
Style SB
8" Bore Size

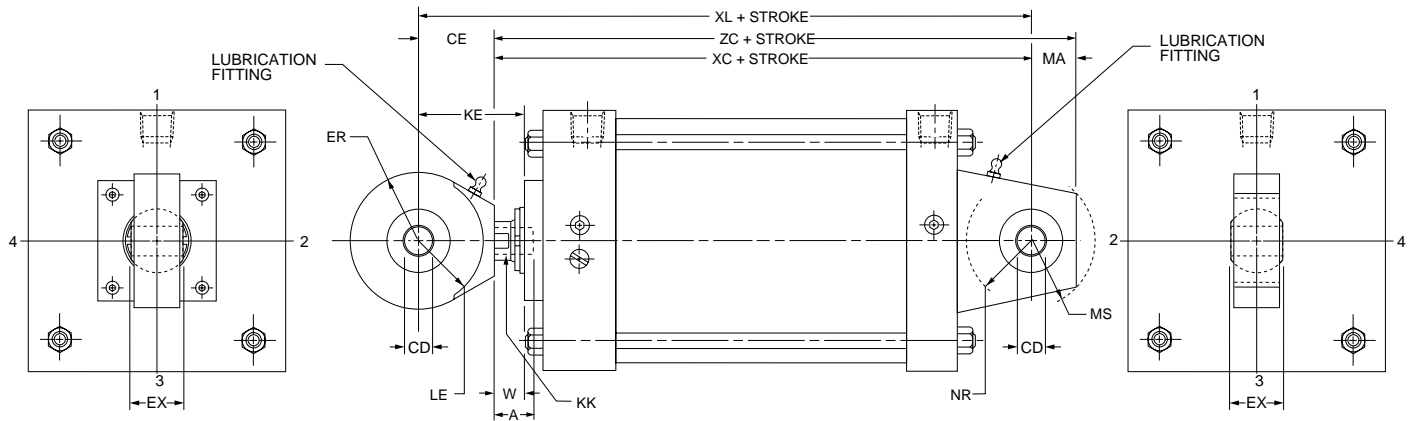

Table 1—Dimensions

Bore	Rod No. 3L	Rod Dia.	Rod End Thread		A	W	Add Stroke				CD*	CE	ER	EX	LE	MA	MS	NR	Max. Oper. PSI	
			Style 9 KK	Style 7 KK			XC	XL	ZC	KE									2A	3L†
8	7	1 ³ / ₈	1-14	—	1 ⁵ / ₈	7/8	8 ¹ / ₄	10 ¹ / ₈	9 ¹ / ₂	2 ³ / ₄	.0005 1.0000	17/8	1 ¹ / ₄	7/8	17/16	1 ¹ / ₄	1 ¹¹ / ₁₆	1 ¹ / ₄	250	250
	2	5 ¹ / ₂	—	1-14	1 ⁵ / ₈	1 ¹ / ₂	8 ⁷ / ₈	10 ³ / ₄	10 ¹ / ₈	3 ³ / ₈										
	8	1 ³ / ₄	—	1-14	1 ⁵ / ₈	1 ¹ / ₈	8 ¹ / ₂	10 ³ / ₈	9 ³ / ₄	3										
	1*	2	—	1-14	1 ⁵ / ₈	1 ¹ / ₄	8 ⁵ / ₈	10 ¹ / ₂	9 ⁷ / ₈	3 ¹ / ₈										
	3	2 ¹ / ₂	—	1-14	1 ⁵ / ₈	1 ¹ / ₂	8 ⁷ / ₈	10 ³ / ₄	10 ¹ / ₈	3 ³ / ₈										
	4	3	—	1-14	1 ⁵ / ₈	1 ¹ / ₂	8 ⁷ / ₈	10 ³ / ₄	10 ¹ / ₈	3 ³ / ₈										
	5	3 ¹ / ₂	—	1-14	1 ⁵ / ₈	1 ¹ / ₂	8 ⁷ / ₈	10 ³ / ₄	10 ¹ / ₈	3 ³ / ₈										
	6	4	—	1-14	1 ⁵ / ₈	1 ¹ / ₂	8 ⁷ / ₈	10 ³ / ₄	10 ¹ / ₈	3 ³ / ₈										
	9	4 ¹ / ₂	—	1-14	1 ⁵ / ₈	1 ¹ / ₂	8 ⁷ / ₈	10 ³ / ₄	10 ¹ / ₈	3 ³ / ₈										
0	5	—	1-14	1 ⁵ / ₈	1 ¹ / ₂	8 ⁷ / ₈	10 ³ / ₄	10 ¹ / ₈	3 ³ / ₈											

Note: For additional dimensions see Series 3L, Style F mount.

* 10, 12 and 14 inch bores are not available in Series 3L Hydraulic Cylinders.

* Dimension CD is hole diameter.

† Maximum operating pressure at 4:1 design factor is based on tensile strength of material. Pressure ratings are based on standard commercial bearing ratings.

Mounting Information Head End Mounting

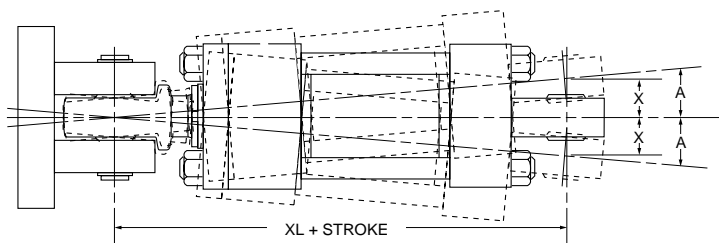

Cap End Mounting

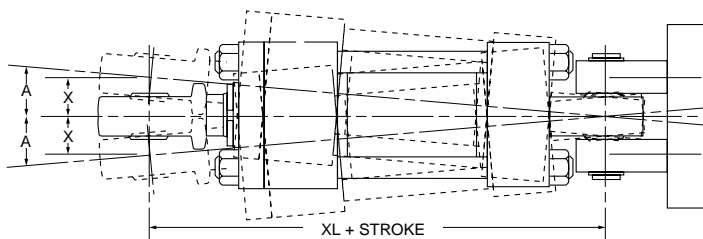

Table 1

Recommended maximum swivel angle on each side of the cylinder centerline.

Bore	Head End Mounted		Cap End Mounted	
	Angle a	Tan. of a	Angle a	Tan. of a
1 ¹ / ₂	2 ¹ / ₂	.035	2 ¹ / ₂	.035
2	2 ¹ / ₂	.044	4 ¹ / ₂	.079
2 ¹ / ₂	2 ¹ / ₂	.044	4 ¹ / ₂	.079
3 ¹ / ₄	3 ¹ / ₂	.052	3 ¹ / ₂	.052
4	2 ¹ / ₂	.044	3 ¹ / ₂	.052
5	3 ¹ / ₂	.052	3 ¹ / ₂	.052
6	3 ¹ / ₂	.052	3 ¹ / ₂	.052

Note: Dimension X is the maximum off center mounting of the cylinder. To determine dimension X for various stroke lengths multiply the distance between pivot pin holes by tangent of angle a. For extended position use X = XL times 2X stroke.

For Cylinder Division Plant Locations – See Page II.

Double Rod Models
1" to 8" Bore Sizes

Series 3L Medium Duty Hydraulic Cylinders

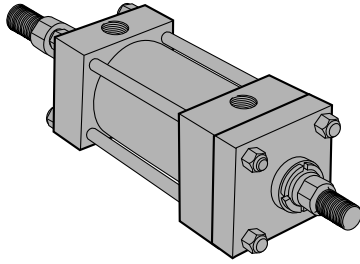

How to Use Double Rod Cylinder Dimensioned Drawings

Rod End #1

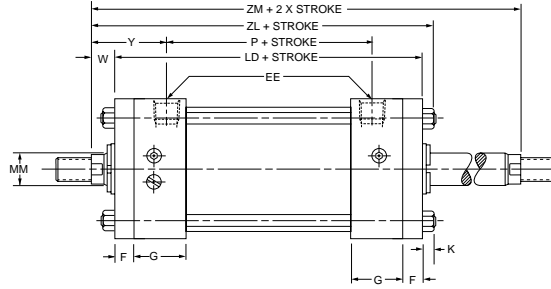

Rod End #2

Rod End #1

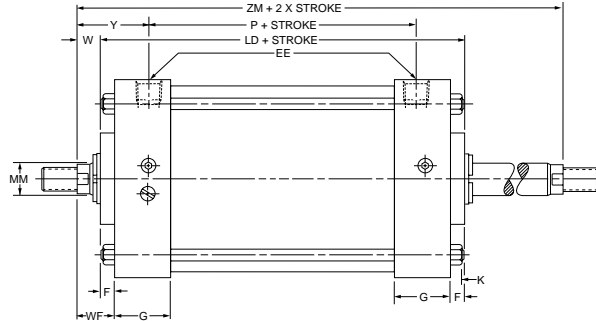

Rod End #2

Mounting Styles for Single Rod Models	Mounting Styles for Corresponding Double Rod Models*	Dimensions Shown on This Page Supplement Dimensions on Pages Listed Below	
		1"-6" Bore Page No.	8" Bore Page No.
T	KT	8	22
TB	KTB	8	22
TD	KTD	8	22
J	KJ	8	—
JB	KJB	10	22
C	KC	12	24
E	KE	12	24
F	KF	14	24
G	KG	14	26
D	KD	16	28
DD	KDD†	16	28

*If only one end of these Double Rod Cylinders is to be cushioned, be sure to specify clearly which end this will be.

†Specify XI dimension from rod end #1.

To determine dimensions for a double rod cylinder, first refer to the desired single rod mounting style cylinder shown on preceding pages of this catalog. (See table at left.) After selecting necessary dimensions from that drawing, return to this page supplement the single rod dimensions with those shown on drawings above and dimension table below. Note that double rod cylinders have a head (Dim. G) at both ends and that dimension LD replaces LB and ZL replaces ZB, etc. The

double rod dimensions differ from, or are in addition to those for single rod cylinders shown on preceding pages and provide the information needed to completely dimension a double rod cylinder.

On a double rod cylinder where the two rod ends are different, be sure to clearly state which rod end is to be assembled at which end. Port position 1 is standard. If other than standard, specify pos. 2, 3 or 4 when viewed from rod end #1 only. (See port position information in Section C.)

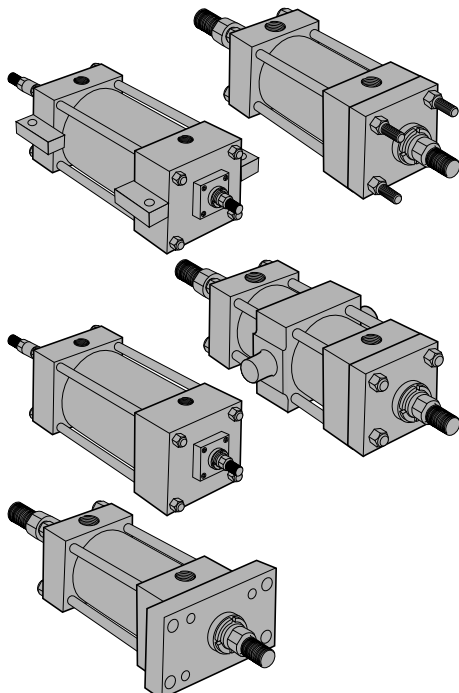

All dimensions are in inches and apply to Code 1 rod sizes only. For alternate rod sizes, determine all envelope dimensions (within LD dim.) as described above and then use appropriate rod end dimensions for proper rod size from single rod cylinder.

Bore	Rod No.	Rod Dia. MM	Add Stroke							Add 2X Stroke ZM
			LD	ZL	SS _K	SN _K	SE _K	XE _K	ZE _K	
1	1	1/2	4 3/4	5 1/2	3 3/8*	2 1/8	*	*	*	6
1 1/2	1	5/8	4 7/8	5 3/4	3 3/8	2 1/4	6 3/8	6 1/4	6 1/2	6 1/8
2	1	5/8	4 7/8	5 13/16	3 3/8	2 1/4	6 3/4	6 7/16	6 3/4	6 1/8
2 1/2	1	1	5	6 5/16	3 1/2	2 3/8	7 1/8	7 1/16	7 3/8	7
3 1/4	1	1	6	7 1/8	3 3/4	2 5/8	7 3/4	7 5/8	8	7 1/2
4	1	1 3/8	6	7 3/8	3 3/4	2 5/8	8	8	8 3/8	8
5	1	1 3/4	6 1/4	7 15/16	3 5/8	2 7/8	8 3/8	8 9/16	9 1/16	8 3/4
6	1	1 3/4	7	8 11/16	4 1/8	3 1/8	9	9 1/8	9 5/8	9 1/4
8	1	2	7 1/8	—	4 1/4	3 1/4	7 7/8	8 3/4	9 3/8	9 5/8
Replaces:			LB	ZB	SS	SN	SE	XE	ZE	—
On single rod mounting styles:			All Mtg. Styles		C,E	F	G			All Mtgs.

* Mounting styles KE, KG and KDD not available in 1" bore size.

For additional information – call your local Parker Cylinder Distributor.

Series 3L Medium Duty Hydraulic Cylinders

Cylinder Accessories Spherical Bearing Mounting Style SB

Parker offers a complete range of Cylinder Accessories to assure you of the greatest versatility in present or future cylinder applications. Accessories offered for the

respective cylinder include the Rod Eye, Pivot Pin and Clevis Bracket. To select the proper part number for any desired accessory refer to the charts below.

Spherical Rod Eye

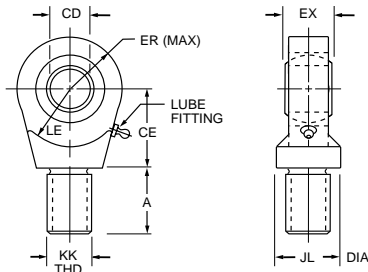

Order to fit Piston Rod Thread Size.

Bore Sizes	Series 2A & 3L	1 1/2, 2 & 2 1/2	3 1/4, 4 & 5	6 & 8	10	12	14
Rod Eye	Part No.	132290	132291	132292	132293	132294	132295
CD		.5000-0005	.7500-0005	1.0000-0005	1.3750-0005	1.7500-0005	2.0000-0005
A		1 1/16	1	1 1/2	2	2 1/8	2 7/8
CE		7/8	1 1/4	1 7/8	2 1/8	2 1/2	2 3/4
EX		7/16	2 1/32	7/8	1 3/16	1 17/32	1 3/4
ER		1 3/16	1 1/8	1 1/4	1 11/16	2 1/16	2 1/2
LE		3/4	1 1/16	1 7/16	1 7/8	2 1/8	2 1/2
KK		7/16-20	3/4-16	1-14	1 1/4-12	1 1/2-12	1 7/8-12
JL		7/8	1 5/16	1 1/2	2	2 1/4	2 3/4
LOAD CAPACITY LBS.		2644	9441	16860	28562	43005	70193

Pivot Pin

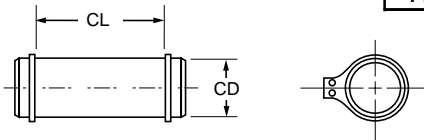

Pivot Pins are furnished with (2) Retainer Rings.

Bore Sizes	Series 2A & 3L	1 1/2, 2 & 2 1/2	3 1/4, 4 & 5	6 & 8	10	12	14
Pivot Pin	Part No.	83962	83963	83964	83965	83966	83967
CD		.4997-0004	.7497-0005	.9997-0005	1.3746-0006	1.7496-0006	1.9996-0007
CL		1 9/16	2 1/32	2 1/2	3 5/16	4 7/32	4 15/16
LOAD CAPACITY LBS.		8600	19300	34300	65000	105200	137400

Clevis Bracket

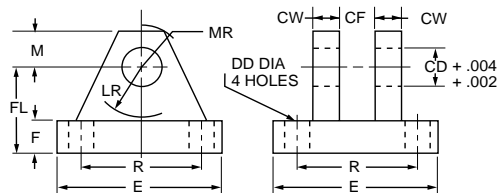

Order to fit Mounting Plate or Rod Eye.

Bore Sizes	Series 2A & 3L	1 1/2, 2 & 2 1/2	3 1/4, 4 & 5	6 & 8	10	12	14
Clevis Bracket	Part No.	83947	83948	83949	83950	83951	83952
CD		1/2	3/4	1	1 3/8	1 3/4	2
CF		7/16	2 1/32	7/8	1 3/16	1 17/32	1 3/4
CW		1/2	5/8	3/4	1	1 1/4	1 1/2
DD		1 3/32	1 7/32	1 7/32	2 1/32	2 9/32	2 9/32
E		3	3 3/4	5 1/2	6 1/2	8 1/2	10 5/8
F		1/2	5/8	3/4	7/8	1 1/4	1 1/2
FL		1 1/2	2	2 1/2	3 1/2	4 1/2	5
LR		1 5/16	1 3/8	1 11/16	2 7/16	2 7/8	3 5/16
M		1/2	7/8	1	1 3/8	1 3/4	2
MR		5/8	1	1 3/16	1 5/8	2 1/16	2 3/8
R		2.05	2.76	4.10	4.95	6.58	7.92
LOAD CAPACITY LBS.		5770	9450	14300	20322	37800	50375

For Cylinder Division Plant Locations – See Page II.

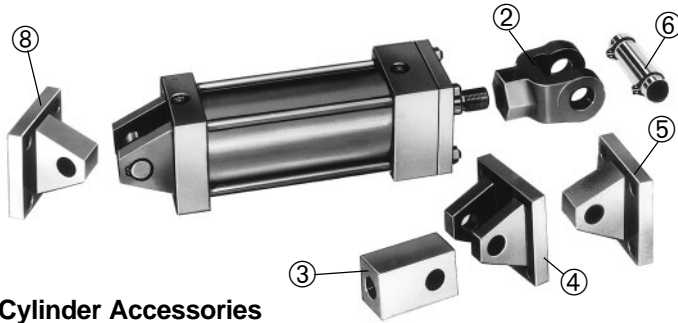

Cylinder Accessories

Parker offers a complete range of cylinder accessories to assure you of greatest versatility in present or future cylinder applications.

Rod End Accessories

Accessories offered for the rod end of the cylinder include Rod Clevis, Eye Bracket, Knuckle, Clevis Bracket and Pivot Pin. To select the proper part number for any desired accessory, refer to Chart A below and look opposite the thread size of the rod end as indicated in the first column. The Pivot Pins, Eye Brackets and Clevis Brackets are listed opposite the thread size which their mating Knuckles or Clevises fit.

Chart A

Thread Size	Mating Parts			Mating Parts			Alignment Coupler
	Rod Clevis	Eye Bracket	Pin	Knuckle	Clevis Bracket	Pin	
5/16-24	51221	74077	—	74075	74076	74078	134757 0031
7/16-20	50940	69195	68368	69089	69205	68368	134757 0044
1/2-20	50941	69195	68368	69090	69205	68368	134757 0050
3/4-16	50942	69196	68369	69091	69206†	68369	134757 0075
3/4-16	133284	69196	68369	69091	69206	68369	134757 0075
7/8-14	50943	*85361	68370	69092	69207	68370	134757 0088
1-14	50944	*85361	68370	69093	69207	68370	134757 0100
1-14	133285	*85361	68370	69093	69207	68370	134757 0100
1 1/4-12	50945	69198	68371	69094	69208	68371	134757 0125
1 1/4-12	133286	69198	68371	69094	69208	68371	134757 0125
1 1/2-12	50946	*85362	68372	69095	69209	68372	133739 0150
1 3/4-12	50947	*85363	68373	69096	69210	69215	133739 0175
1 7/8-12	50948	*85363	68373	69097	69210	69215	133739 0188
2 1/4-12	50949	*85364	68374	69098	69211	68374	Consult Factory
2 1/2-12	50950	*85365	68375	69099	69212	68375	
2 3/4-12	50951	*85365	68375	69100	69213	69216	
3 1/4-12	50952	73538	73545	73536	73542	73545	
3 1/2-12	50953	73539	73547	73437	73542	73545	
4-12	50954	73539	73547	73438	73543	82181	
4 1/2-12	—	—	—	73439	73544	73547	

†For alignment coupler dimensions, see Section C.

*Cylinder accessory dimensions conform to NFPA recommended standard NFPA/T3.6.8 R1-1984, NFPA recommended standard fluid power systems — cylinder — dimensions for accessories for cataloged square head industrial types. Parker adopted this standard in April, 1985. Eye Brackets or Mounting Plates shipped before this date may have different dimensions and will not necessarily interchange with the NFPA standard. For dimensional information on older style Eye Brackets or Mounting Plates consult Drawing #144805 or previous issues of this catalog.

Note: For economical accessory selection, it is recommended that rod end style 4 be specified on your cylinder order.

Accessory Load Capacity

The various accessories on this page and the following page have been load rated for your convenience. The load capacity in lbs. shown on the following page is the recommended maximum load for that accessory based on a 4:1 design factor in tension. (Pivot Pin is rated in shear.) Before specifying, compare the actual load or the tension (pull) force at maximum operating pressure of the cylinder with the load capacity of the accessory you plan to use. If load or pull force of cylinder exceeds load capacity of accessory, consult factory.

Chart B

Mtg. Plate	Series 3L
Part No.	Bore Size
74076‡	1"
69195	1 1/2", 2", 2 1/2"
69196	3 1/4", 4", 5"
*85361	6"
*85361	8"

‡Mounting plate for 1" bore single lug BC & BB cylinder mounting style is Clevis Bracket P/N 74076.

Mounting Plates

Mounting Plates for Style BB and Style BC (Clevis mounted) cylinders are offered. To select proper part number for your application, refer to Chart B to above right.

② Female Rod Clevis

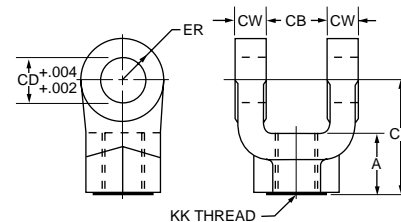

Order to fit thread size.

③ Knuckle (Female Rod Eye)

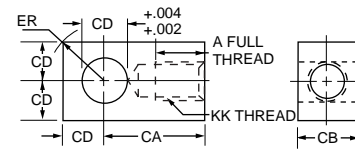

Order to fit thread size.

④ Clevis Bracket for Knuckle

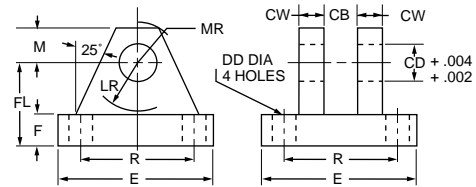

Order to fit Knuckle.

⑧ Mounting Plate or ⑤ Eye Bracket

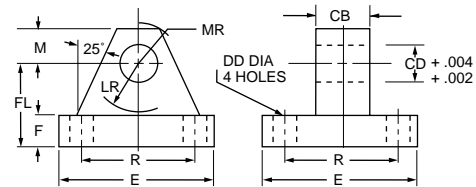

1. When used to mate with the Rod Clevis, select from Chart A.
2. When used to mount the Style BB or BC cylinders, select from the Mounting Plate Selection Table. See Chart B at lower left.

⑥ Pivot Pin

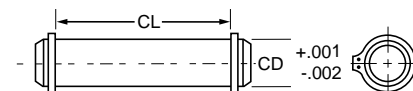

1. Pivot Pins are furnished with Clevis Mounted Cylinders as standard.
2. Pivot Pins are furnished with (2) Retainer Rings.
3. Pivot Pins must be ordered as separate item if to be used with Knuckles, Rod Clevises, or Clevis Brackets.

For additional information – call your local Parker Cylinder Distributor.

Series 3L Medium Duty Hydraulic Cylinders

Cylinder Accessories

	Female Rod Clevis Part Number																		
	51221 [†]	50940	50941	50942	133284	50943	50944	133285	50945	133286	50946	50947	50948	50949	50950	50951	50952	50953	50954
A	1 ³ / ₁₆	3/4	3/4	1 1/8	1 1/8	1 5/8	1 5/8	1 5/8	1 7/8	2	2 1/4	3	3	3 1/2	3 1/2	3 1/2	3 1/2	4 [‡]	4 [‡]
CB	1 1/32	3/4	3/4	1 1/4	1 1/4	1 1/2	1 1/2	1 1/2	2	2	2 1/2	2 1/2	2 1/2	3	3	3	4	4 1/2	4 1/2
CD	5/16	1/2	1/2	3/4	3/4	1	1	1	1 3/8	1 3/8	1 3/4	2	2	2 1/2	3	3	3 1/2	4	4
CE	2 1/4	1 1/2	1 1/2	2 1/8	2 3/8	2 15/16	2 15/16	3 1/8	3 3/4	4 1/8	4 1/2	5 1/2	5 1/2	6 1/2	6 3/4	6 3/4	7 3/4	8 13/16	8 13/16
CW	1 3/64	1/2	1/2	5/8	5/8	3/4	3/4	3/4	1	1	1 1/4	1 1/4	1 1/4	1 1/2	1 1/2	1 1/2	2	2 1/4	2 1/4
ER	1 9/64	1/2	1/2	3/4	3/4	1	1	1	1 3/8	1 3/8	1 3/4	2	2	2 1/2	2 3/4	2 3/4	3 1/2	4	4
KK	5/16-24	7/16-20	1/2-20	3/4-16	3/4-16	7/8-14	1-14	1-14	1 1/4-12	1 1/4-12	1 1/2-12	1 3/4-12	1 7/8-12	2 1/4-12	2 1/2-12	2 3/4-12	3 1/4-12	3 1/2-12	4-12
Load Capacity Lbs. ⓐ	2600	4250	4900	11200	11200	18800	19500	19500	33500	33500	45600	65600	65600	98200	98200	98200	156700	193200	221200

	Knuckle Part Number																
	74075	69089	69090	69091	69092	69093	69094	69095	69096	69097	69098	69099	69100	73536	73437	73438	73439
A	3/4	3/4	3/4	1 1/8	1 1/8	1 5/8	2	2 1/4	2 1/4	3	3 1/2	3 1/2	3 5/8	4 1/2	5	5 1/2	5 1/2
CA	1 1/2	1 1/2	1 1/2	2 1/16	2 3/8	2 13/16	3 7/16	4	4 3/8	5	5 13/16	6 1/8	6 1/2	7 5/8	7 5/8	9 1/8	9 1/8
CB	7/16	3/4	3/4	1 1/4	1 1/2	1 1/2	2	2 1/2	2 1/2	2 1/2	3	3	3 1/2	4	4	4 1/2	5
CD	7/16	1/2	1/2	1 1/4	1	1	1 3/8	1 3/4	2	2	2 1/2	3	3	3 1/2	3 1/2	4	4
ER	1 9/32	2 3/32	2 3/32	3 1/16	1 7/16	1 7/16	1 31/32	2 1/2	2 27/32	2 27/32	3 9/16	4 1/4	4 1/4	4 31/32	4 31/32	5 11/16	5 11/16
KK	5/16-24	7/16-20	1/2-20	3/4-16	7/8-14	1-14	1 1/4-12	1 1/2-12	1 3/4-12	1 7/8-12	2 1/4-12	2 1/2-12	2 3/4-12	3 1/4-12	3 1/2-12	4-12	4 1/2-12
Load Capacity Lbs. ⓐ	3300	5000	5700	12100	13000	21700	33500	45000	53500	75000	98700	110000	123300	161300	217300	273800	308500

	Clevis Bracket for Knuckle Part Number													
	74076	69205	69206	69207	69208	69209	69210	69211	69212	69213	73542	73543	73544	
CB	1 5/32	3/4	1 1/4	1 1/2	2	2 1/2	2 1/2	3	3	3 1/2	4	4 1/2	5	
CD	7/16	1/2	3/4	1	1 3/8	1 3/4	2	2 1/2	3	3	3 1/2	4	4	
CW	3/8	1/2	5/8	3/4	1	1 1/4	1 1/2	1 1/2	1 1/2	1 1/2	2	2	2	
DD	1 17/64	1 13/32	1 17/32	2 1/32	2 1/32	2 29/32	3 1/16	3 1/16	3 15/16	4 1/16	4 11/16	5 1/16	5 21/16	
E	2 1/4	3 1/2	5	6 1/2	7 1/2	9 1/2	12 3/4	12 3/4	12 3/4	12 3/4	15 1/2	17 1/2	17 1/2	
F	3/8	1/2	5/8	3/4	7/8	7/8	1	1	1	1	1 11/16	1 15/16	1 15/16	
FL	1	1 1/2	1 7/8	2 1/4	3	3 5/8	4 1/4	4 1/2	6	6	6 11/16	7 11/16	7 11/16	
LR	5/8	3/4	1 3/16	1 1/2	2	2 3/4	3 3/16	3 1/2	4 1/4	4 1/4	5	5 3/4	5 3/4	
M	3/8	1/2	3/4	1	1 3/8	1 3/4	2 1/4	2 1/2	3	3	3 1/2	4	4	
MR	1/2	5/8	2 9/32	1 1/4	1 21/32	2 7/32	2 25/32	3 1/8	3 19/32	3 19/32	4 1/8	4 7/8	4 7/8	
R	1.75	2.55	3.82	4.95	5.73	7.50	9.40	9.40	9.40	9.40	12.00	13.75	13.75	
Load Capacity Lbs. ⓐ	3600	7300	14000	19200	36900	34000	33000	34900	33800	36900	83500	102600	108400	

	Eye Bracket and Mounting Plate Part Number											
	74077	69195	69196	85361*	69198	85362*	85363*	85364*	85365*	73538	73539	
CB	5/16	3/4	1 1/4	1 1/2	2	2 1/2	2 1/2	3	3	4	4 1/2	
CD	5/16	1/2	3/4	1	1 3/8	1 3/4	2	2 1/2	3	3 1/2	4	
DD	1 17/64	1 13/32	1 17/32	2 1/32	2 1/32	2 29/32	3 1/16	3 1/16	3 15/16	4 11/16	4 21/16	
E	2 1/4	2 1/2	3 1/2	4 1/2	5	6 1/2	7 1/2	8 1/2	9 1/2	12 5/8	14 7/8	
F	3/8	3/8	5/8	7/8	7/8	1 1/8	1 1/2	1 3/4	2	1 11/16	1 15/16	
FL	1	1 1/8	1 7/8	2 3/8	3	3 3/8	4	4 3/4	5 1/4	5 11/16	6 7/16	
LR	5/8	3/4	1 1/4	1 1/2	2 1/8	2 1/4	2 1/2	3	3 1/4	4	4 1/2	
M	3/8	1/2	3/4	1	1 3/8	1 3/4	2	2 1/2	2 3/4	3 1/2	4	
MR	1/2	9/16	7/8	1 1/4	1 5/8	2 1/8	2 7/16	3	3 1/4	4 1/8	5 1/4	
R	1.75	1.63	2.55	3.25	3.82	4.95	5.73	6.58	7.50	9.62	11.45	
Load Capacity Lbs. ⓐ	1700	4100	10500	20400	21200	49480	70000	94200	121900	57400	75000	

	Pivot Pin Part Number													
	74078	68368	68369	68370	68371	68372	68373	69215	68374	68375	69216	73545	82181	73547*
CD	7/16	1/2	3/4	1	1 3/8	1 3/4	2	2	2 1/2	3	3	3 1/2	4	4
CL	1 5/16	1 7/8	2 5/8	3 1/8	4 1/8	5 3/16	5 3/16	5 11/16	6 3/16	6 1/4	6 3/4	8 1/4	8 5/8	9
Shear Capacity Lbs. ⓐ	6600	8600	19300	34300	65000	105200	137400	137400	214700	309200	309200	420900	565800	565800

*Cylinder accessory dimensions conform to NFPA recommended standard NFPA/T3.6.8 R1-1984, NFPA recommended standard fluid power systems — cylinder — dimensions for accessories for cataloged square head industrial types. Parker adopted this standard in April, 1985. Eye Brackets or Mounting Plates shipped before this date may have different dimensions and will not necessarily interchange with the NFPA standard. For dimensional information on older style Eye Brackets or Mounting Plates consult Drawing #144805 or previous issues of this catalog.

ⓐ See Accessory Load Capacity note on previous page.

*These sizes supplied with cotter pins.

†Includes Pivot Pin.

Consult appropriate cylinder rod end dimensions for compatibility.

For Cylinder Division Plant Locations – See Page II.

Series 3L Medium Duty Hydraulic Cylinders

How to Order

How to Order Series “3L” Cylinders

When ordering Series 3L cylinders, please review the following:

Note: Duplicate cylinders can be ordered by giving the SERIAL NUMBER from the nameplate of the original cylinder. Factory records supply a quick positive identification.

Piston Rods: Specify rod code number based on diameter. Give thread style number for a standard thread or specify dimensions. See “Style 3 Rod End” below.

Cushions: If cushions are required specify according to the model number on the next page. If the cylinder is to have a double rod and only one cushion is required, be sure to specify clearly which end of the cylinder is to be cushioned.

Special Modifications: Additional information is required on orders for cylinders with special modifications. This is best handled with descriptive notes. For further information, consult factory.

Additional Lipseal® Piston (if desired): Parker Lipseal® pistons are offered as an option at no extra cost in the Series 3L cylinders. With this feature, zero leakage under static holding conditions is attained. Call out “with Lipseal piston” if this type of piston is desired. If not specified, the ring type piston will be furnished.

Fluid Medium: Series 3L hydraulic cylinders are equipped with seals for use with hydraulic oil. If other than hydraulic oil will be used, specify class of fluid (See Catalog section C.)

See Section C for pressure ratings relating to bore and rod sizes.

Water Service Modifications

Standard – When requested, Parker can supply Series 3L cylinders with standard modifications that make the cylinders more nearly suitable for use with water as the fluid medium. The modifications include chrome-plated cylinder bore; electroless nickel-plated, non-wearing internal surfaces; Lipseal style piston, Buna N Seals and chrome-plated, stainless steel piston rod. On orders for water service cylinders, be sure to specify the maximum operating pressure.

(These factors must be taken into account because of the lower tensile strength of stainless steels available for use in piston rods.)

Warranty– Parker will warrant Series 3L cylinders modified for water service to be free of defects in materials or workmanship. On the other hand, Parker cannot accept responsibility for premature failure of cylinder function, where failure is caused by corrosion, electrolysis or mineral deposits within the cylinder.

Class 1 Seals

Class 1 seals are the seals provided as standard in a cylinder assembly unless otherwise specified. For further information on fluid compatibility or operating limitations of all components, see section C.

For the 3L series cylinders the following make-up Class 1 Seals:

Primary Piston Rod Seal – Enhanced Polyurethane

Piston Rod Wiper – Nitrile

Piston Seals – Cast Iron Rings

Option – Nitrile lipseals with polymyte back-up washers

O-Rings – Nitrile (nitrile back-up washer when used)

Combination Mountings

Single Rod End The first mounting is the one called out on the head end of the cylinder. The second or subsequent mountings are called out as they appear in the assembly moving away from the rod end. Exception: When tie rod mountings are part of a combination, the model number should contain an “S” (Special) in the model code and a note in the body of the order clarifying the mounting arrangement. The “P” is used to define a thrust key and is not considered to be a mounting. However, it is located at the primary end.

Example: 4.00 CCB3LLTS14AC x 10.000

Combination “C” mounting head only. “BB” mounting cap end

This cylinder is also cushioned at both ends.

Double Rod End In general, the model number is read left to right corresponding to the cylinder as viewed from left to right with the

primary end at rod end #1. See Double Rod Models information page in this section. For this option the piston rod number, piston rod end, and piston rod threads are to be specified for both ends. The simplest are for symmetric cylinders such as: TD, C, E, F, G, and CB mounts. All other mounting styles, the description of the first rod end will be at the mounting end. In the case of multiple mounts, the description of the first rod end will be at the primary mounting end. For “DD” mounts, the description of the first rod end will be the same location as the “XI” dimension.

Example: 4.00 KDD3LLT24A/18A x 10.000 XI=8

This is a center trunnion mounting cylinder with the XI dimension measured from the code 2 rod side of the cylinder which has the style 4 thread. The opposite end code 1 rod with the style 8 thread.

Style 3 Rod End

A style 3 rod end indicates a special rod end configuration. All special piston rod dimensions must have **all three:** KK; A; W/WF or LA/LAF specified with the rod fully retracted. A sketch or drawing should be submitted for rod ends requiring special machining such as snap ring grooves, keyways, tapers, multiple diameters, etc. It is good design practice to have this machining done on a diameter at least 0.065 inches smaller than the piston rod diameter. This allows the piston rod to have a chamfer preventing rod seal damage during assembly or

maintenance. Standard style 55 rod ends with a longer than standard WG dimension should call out a style 3 rod end and the note: **same as 55 except WG=_____**. A drawing should be submitted for special 55 rod ends that have specific tolerances or special radii. Special rod ends that have smaller than standard male threads, larger than standard female threads, or style 55 rod ends with smaller than standard AF or AE dimensions are to be reviewed by Engineering for proper strength at operating pressure.

Service Policy

On cylinders returned to the factory for repairs, it is standard policy for the Cylinder Division to make such part replacements as will put the cylinder in as good as new condition. Should the condition of the returned cylinder be such that expenses for repair would exceed the costs of a new one, you will be notified.

Address all correspondence and make shipments to, Service Department at your nearest regional plant listed in the pages of this catalog.

Certified Dimensions

Parker Cylinder Division guarantees that all cylinders ordered from this catalog will be built to dimensions shown. All dimensions are certified to be correct, and thus it is not necessary to request certified drawings.

For additional information – call your local Parker Cylinder Distributor.

Series 3L Medium Duty Hydraulic Cylinders

Model Numbers

Series 3L Model Numbers – How to Develop Them – How to “Decode” Them

Parker Series 3L cylinders can be completely and accurately described by a model number consisting of coded symbols. To develop a model number, select only those symbols that represent the cylinder required,

and place them in the sequence indicated below.

Note: Page numbers with a letter prefix, ie: C77, are located in section C of this catalog.

Feature	Description	Page No.	Symbol
Bore*	Specify in inches	—	—
Cushion-Head	Used only if cushion required	6	C
Double-Rod	Used only if double-rod cylinder is required	32	K
Mounting* Style	Head Tie Rods Extended	8 & 22	TB
	Cap Tie Rods Extended	8 & 22	TC
	Both End Tie Rods Extended	8 & 22	TD
	Head Rectangular Flange	8	J
	Cap Rectangular Flange	8	H
	Head Square Flange	10 & 22	JB
	Cap Square Flange	10 & 22	HB
	Side Lugs	12 & 24	C†
	Centerline Lugs	12 & 24	E
	Side Tapped	14 & 24	F†
	Side End Lugs	14 & 26	G†
	Head Trunnion	16 & 28	D
	Cap Trunnion	16 & 28	DB
	Intermediate Fixed Trunnion‡	16 & 28	DD
	Cap Fixed Clevis	18 & 26	BB
	Cap Detachable Clevis	18	BC
Spherical Bearing	30 & 31	SB	
Head Rectangular	20	JJ	
Mounting Modifications	Used only for Thrust Key (Styles C, F & G)	C93	P
	Used only for Manifold Port O-Ring Seal (Style C)	C91	M
Combination Mounting Style	Any Practical Mounting Style Listed Above	—	As listed above
		—	—
Series*	Used in all 3L Model Numbers	—	-3L
Piston	Ring packed piston is standard.	—	C
	Use only for Lipseal® Piston.	6 & 7	L
Ports*	SAE Straight Thread O-Ring Port	C89	T
	Used only for NPTF (Dry Seal Pipe Thread)	C89	U
	Used only for BSP (Parallel Thread ISO 228)	C89	R
	Used only for BSPT (Taper Thread)	C89	B
	Used only for Metric Thread	C89	G
	Used only for Metric Thread per ISO 6149	C89	Y
Common Modifications	High Water Content Fluid	C83	J
	Nut Retained Piston	7	F
	Fluorocarbon Seals	C83	V
	Water Service	C83	W
EPR Seals	C83	X	
Special Modifications	Used only if special Modifications are required:		
	Oversize Ports	C91	S
	Port Position Change	C89	
	Rod End Bellows	C104	
	Special Seals	C83	
	Stop Tube*	C95	
Stroke Adjuster	C93		
Tie Rod Supports	C93		
Piston Rod* Number	For Single Rod Cylinders, select one only. Refer to Rod number listing, Table 2, Catalog Pages 8 through 27. See chart in Section C, page 83 for minimum piston rod diameter	—	1
		—	2
		—	3
		—	4
		—	5
		—	6
		—	7
		—	8
		—	9
		—	0
Piston* Rod End	Select:		
	Style 4 Small Male	C92	4
	Style 7 Female Thread for Spherical Rod Eye	B30, 31	7
	Style 8 Intermediate Male	C92	8
	Style 9 Short Female	C92	9
	Style 55 Rod End for Flange Coupling	C19	55
Style 3 Special (Specify)	C92	3	
Piston Rod Alternate Thread	Used only for stud two times longer than standard.	C92	2
Piston Rod* Threads	UNF Standard	C92	A
	BSF (British Fine)	C92	W
	Metric	C92	M
Cushion-Cap	Used only if cushion required	6	C
Stroke**	Specify in inches	C96	—

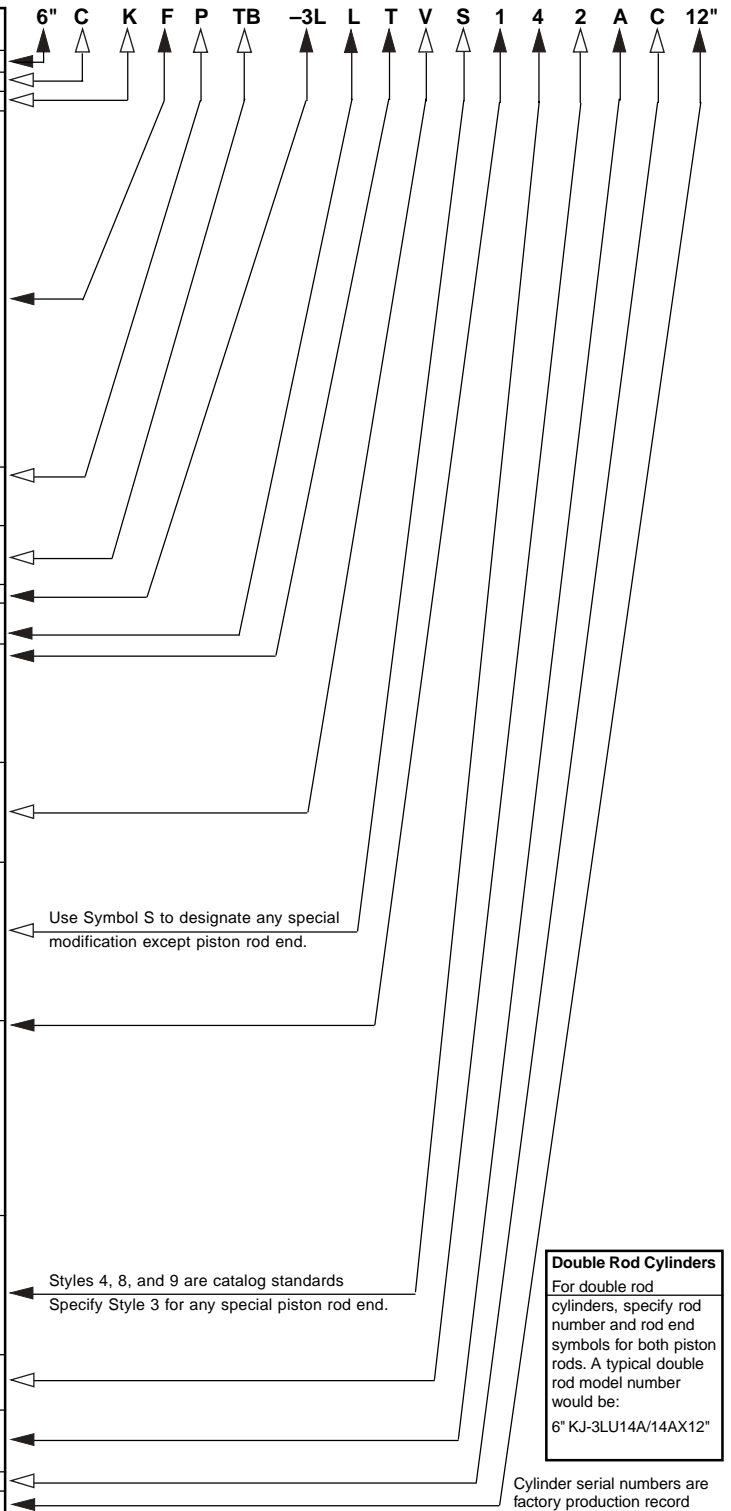

*Required for Basic Cylinder Model Number
*In case of Stop Tube, call out Gross Stroke Length

†Cylinders with these mounting styles should have a minimum stroke length equal to or greater than their bore size.

Dark Arrows Indicate Basic Minimum Model Number
‡Specify XI dimension

Cylinder serial numbers are factory production record numbers and are assigned to each cylinder, in addition to the model number.

For Cylinder Division Plant Locations – See Page II.



Parker TS-2000 seal designed to eliminate cylinder rod seal leakage.

Parker Series 2H Heavy Duty and Series 3L Medium Duty Hydraulic Cylinders with the TS-2000 seal offers positive protection against cylinder rod leakage under the most demanding applications.

The TS-2000 seal is the product of countless hours of research, development and extensive field testing and is only available on Parker Cylinders.

Based on the popular Parker Serrated Lipseal rod design, the TS-2000 incorporates the pressure-compensated, uni-directional characteristics of a U-cup with the multiple edge sealing effectiveness of compression-type stacked-packings.

The goal for the Parker team was to design a rod seal suitable for all types of applications, regardless of pressure profile. It had to be composed of a

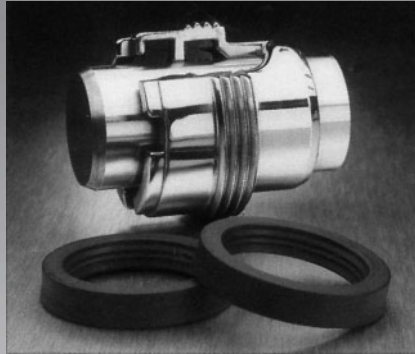

“Jewel” gland with wiperseal and TS-2000 cylinder rod seal.

material that would not react chemically with hydraulic fluids. And it had to produce better and more reliable “dry rod” performance than the standard serrated lip-seal design in a broad range of applications.

The result is the TS-2000 seal, designed especially to eliminate rod seal leakage in the most demanding applications. It features a special polyurethane material that will not react chemically with petroleum-based hydraulic fluid, is extremely resistant to abrasion and extrusion, and provides exceptional service life. It has more sealing edges than other seals on the market, which

in turn produces “dry rod” performance. The seal geometry was refined for maximum stability in the groove and has excellent performance characteristics throughout a broad range of pressures and piston rod velocities.

The Parker design team was successful!

TS-2000 rod seal has not failed in any of the test applications in the lab or on the job, no matter how tough or demanding.

For more information on the TS-2000 call or write your local Parker distributor or Parker Hannifin Corporation, Cylinder Division, 500 S. Wolf Road, Des Plaines, IL 60016, 847-298-2400.

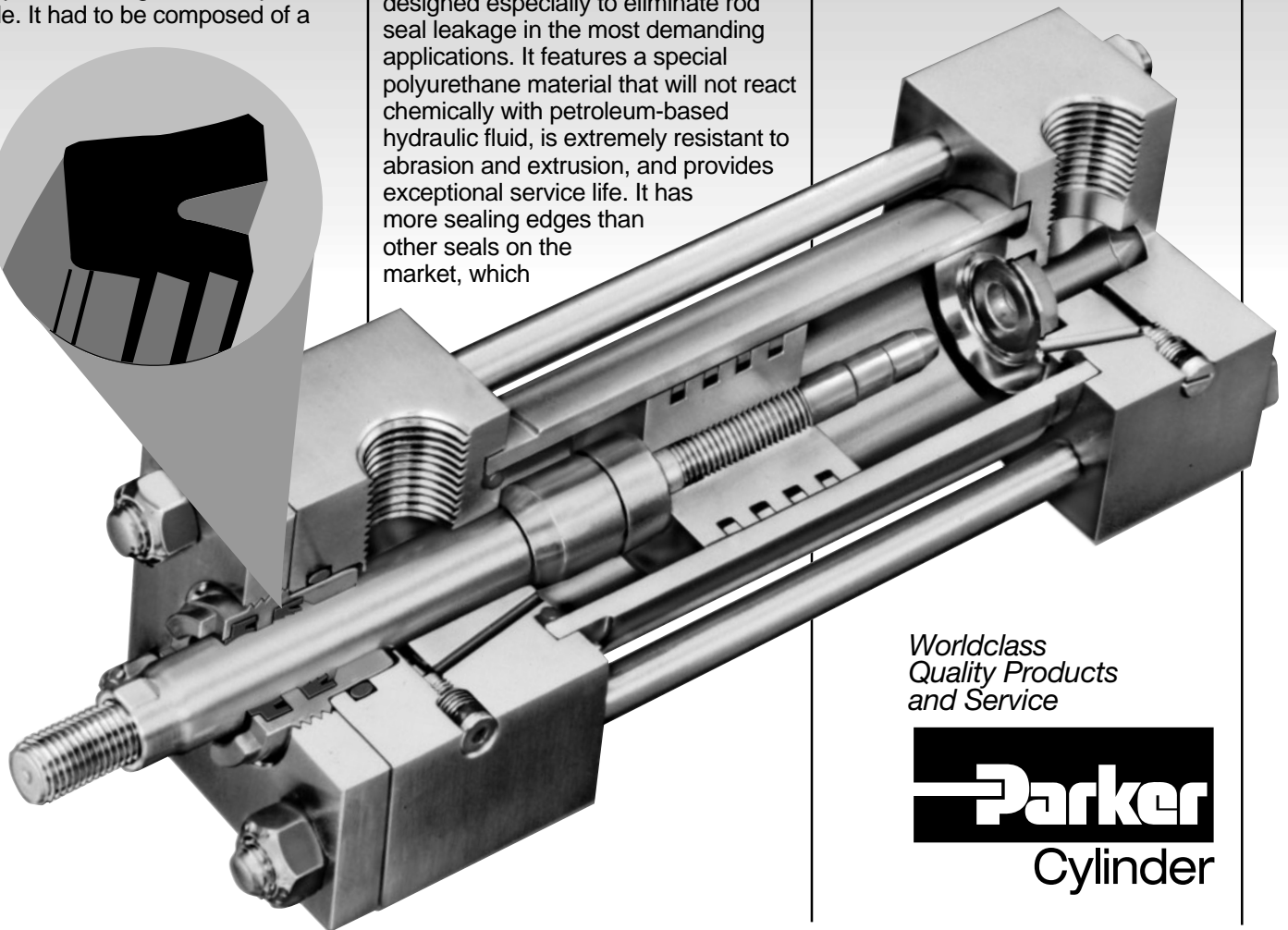
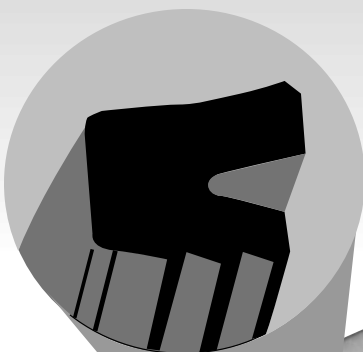

*Worldclass
Quality Products
and Service*

Parker
Cylinder

For additional information – call your local Parker Cylinder Distributor.