

# Variable displacement axial piston pump type C40V

## Product documentation



Open circuit

Nominal pressure  $p_{\text{nom max}}$ :

280 bar

Peak pressure  $p_{\text{max}}$ :

320 bar

Displacement volume  $V_{\text{max}}$ :

100 cm<sup>3</sup>/rev



© by HAWE Hydraulik SE.

The reproduction and distribution of this document, as well as the use and communication of its contents to others without explicit authorization, is prohibited.

Offenders will be held liable for the payment of damages.

All rights reserved in the event of patent or utility model applications.

Brand names, product names and trademarks are not specifically indicated. In particular with regard to registered and protected names and trademarks, usage is subject to legal provisions.

HAWE Hydraulik respects these legal provisions in all cases.

HAWE Hydraulik cannot provide individual guarantees that the stated circuits or procedures (including in part) are not subject to the intellectual property rights of third parties.

Printing date / document generated on: 2023-01-11

## Table of Contents

<b>1</b>	<b>Overview variable displacement axial piston pump type C40V.....</b>	<b>4</b>
<b>2</b>	<b>Available versions.....</b>	<b>5</b>
2.1	Basic type and nominal size.....	5
2.2	Controller.....	6
2.2.1	Load-sensing controllers LS0DA/LS2DA.....	7
2.2.2	Load-sensing controllers LS0DE.. / LS2DE.....	9
2.2.3	Pressure controller DF-DA.....	12
2.2.4	Pressure controller DE.....	13
2.2.5	Flow controller VE.....	15
2.2.6	Power controller LR.....	16
2.3	Solenoid voltage and version.....	17
2.4	Seals.....	17
2.5	Rotation direction.....	17
2.6	Flange versions (input side).....	17
2.7	Shaft journal.....	18
2.8	Housing versions.....	18
2.9	Thru-shaft.....	19
2.10	Pivoting angle of stops.....	19
2.11	Special versions and options.....	19
<b>3</b>	<b>Parameters.....</b>	<b>20</b>
3.1	General data.....	20
3.2	Weight.....	21
3.3	Pressure and delivery flow.....	21
3.4	Characteristic lines.....	22
3.5	Electrical data.....	23
<b>4</b>	<b>Dimensions.....</b>	<b>24</b>
4.1	Basic pump.....	24
4.1.1	C40V-028.....	24
4.1.2	C40V-045.....	28
4.1.3	C40V-085.....	32
4.1.4	C40V-100.....	36
4.2	Controllers.....	40
<b>5</b>	<b>Installation, operation and maintenance information.....</b>	<b>41</b>
5.1	Intended use.....	41
5.2	Assembly information.....	41
5.2.1	General information.....	42
5.2.2	Connections.....	43
5.2.3	Installation positions.....	44
5.3	Operating instructions.....	45
5.4	Maintenance information.....	45
<b>6</b>	<b>Other information.....</b>	<b>46</b>
6.1	Planning information.....	46

**1****Overview variable displacement axial piston pump type C40V**

Variable displacement axial piston pumps adjust the geometric output volume from maximum to zero. As a result they vary the flow rate that is provided to the consumers.

The variable displacement axial piston pump type C40V is designed for open circuits in mobile hydraulics and operates according to the swash plate principle.

The range of pump controllers allows the axial piston pump to be used in a variety of applications.

**Features and advantages**

- Optimized power-to-weight ratio
- Broad selection of controllers
- Thru-shaft compatibility
- High self-suction speed
- Compact design

**Intended applications**

- Machines for forestry and agricultural purposes
- Municipal trucks
- Construction machines
- Fan control systems
- lifting platforms



*Variable displacement axial piston pump type C40V*



## 2.2 Controller

### Load-sensing controller

Coding	Description
LSODA	Load-sensing controller with integrated pressure limitation (Standard version for combination with hydraulic valves that relieve the LS signal in the valve, for example, type PSV proportional directional spool valve), see Chapter 2.2.1, "Load-sensing controllers LSODA/LS2DA"
LS2DA	Load-sensing controller with integrated pressure limitation and additional LS relief (only for use with hydraulic valves without their own relief of the LS signal), see Chapter 2.2.1, "Load-sensing controllers LSODA/LS2DA"
LSODE..	Load-sensing controller with electro-proportional pressure limitation, see Chapter 2.2.2, "Load-sensing controllers LSODE.. / LS2DE.."
LS2DE..	Load-sensing controller with electro-proportional pressure limitation and additional LS relief, see Chapter 2.2.2, "Load-sensing controllers LSODE.. / LS2DE.."

### Pressure controller

Coding	Description
DF-DA	Mechanically adjustable pressure controller with remote-control port, see Chapter 2.2.3, "Pressure controller DF-DA"
DE..	Electro-proportional pressure controller with rising or falling characteristic line, see Chapter 2.2.4, "Pressure controller DE.."

### Delivery flow controller

Coding	Description
VE..	Electro-proportional delivery flow controller with rising characteristic line, see Chapter 2.2.6, "Power controller LR"

### Power controller

Coding	Description
LR	Power controller, see Chapter 2.2.6, "Power controller LR"

#### INFORMATION

For electrically operated controllers, ".." must be replaced by a coding from the table, see Chapter 2.3, "Solenoid voltage and version". Depending on the desired version. Ordering example: DE5

## 2.2.1 Load-sensing controllers LS0DA/LS2DA

The LS0DA, LS2DA controllers are flow controllers that generate a variable, speed-independent flow rate. They adapt the displacement volume of the pump to the required flow rate of the consumer and regulate a constant difference between load pressure and pump pressure.

The integrated pressure limitation restricts the maximum pressure to a set value.

### LS0DA

- Connection X2-T sealed
- Version for combination with hydraulic valves that relieve the LS signal in the valve, for example, type PSV proportional directional spool valve

### LS2DA

- Connection X2-T open
- Only for use with hydraulic valves without their own relief of the LS signal

### LS0DA

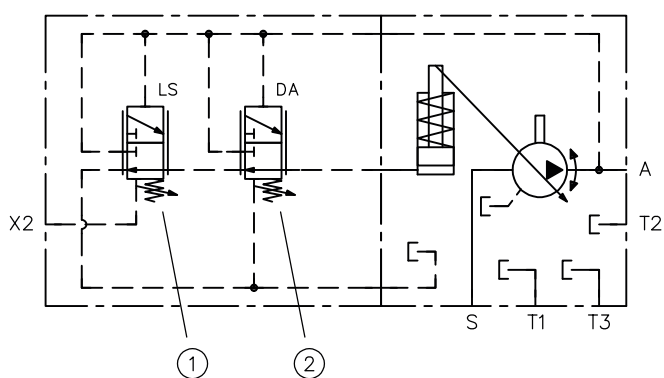

### LS2DA

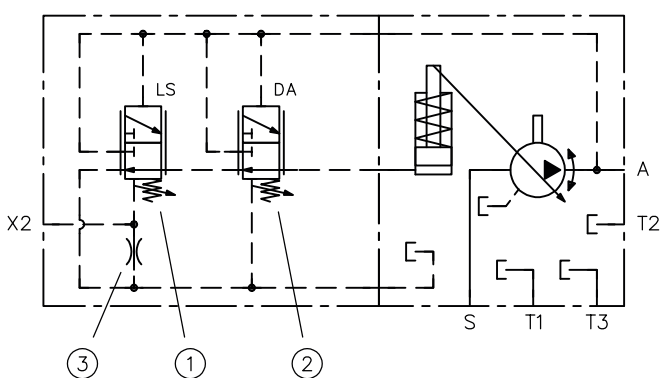

- 1 **LS controller:** Regulates a constant difference between load pressure and pump pressure
- 2 **Pressure limitation:** Limits the pump pressure to a maximum value
- 3 **LS signal relief**

**Characteristic lines for LSODA and LS2DA**

**LS function**

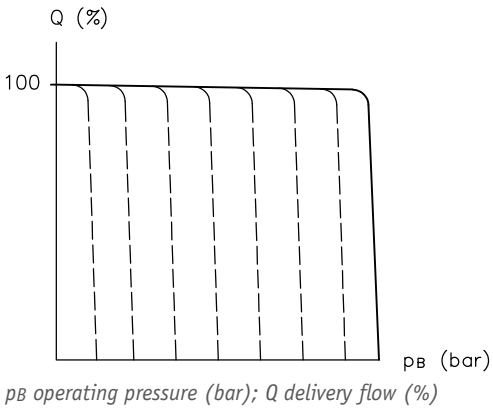

**DA function**

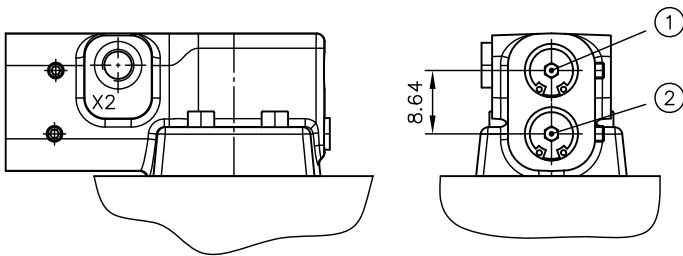
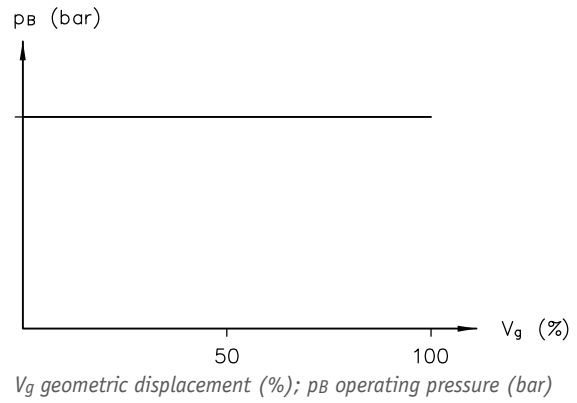

- 1 LS setting screw
- 2 DA setting screw

**Pressure adjustment**

Pressure adjustment	Pressure range (bar)	$\Delta p$ (bar)/revolution	Factory-set pressure setting (bar)
Maximum pressure $p_{max}$	150 ... 280	105	280
Differential pressure $\Delta p$	14 ... 25	50	19



## 2.2.2 Load-sensing controllers LSODE.. / LS2DE..

The LSODE.. LS2DE.. controllers are a combination of load-sensing controller and electro-proportional pressure controller.

They are typically used to simultaneously supply the working functions and the fan with a pump.

The load-sensing controller (LS) generates a variable flow rate independently of the speed. It adapts the geometric displacement of the pump to the required flow rate of the consumer and regulates a constant difference between load pressure and pump pressure.

The DE.. controller regulates the pump pressure on the basis of an electro-proportional input signal. As soon as the set value is exceeded, the controller reduces the pivoting angle of the pump and regulates a constant pressure level.

### LSODE..

- Connection X2-T sealed
- Version for combination with hydraulic valves that relieve the LS signal in the valve, for example, type PSV proportional directional spool valve

### LS2DE..

- Connection X2-T open
- Only for use with hydraulic valves without their own relief of the LS signal

**Solenoid voltage and version:** see Chapter 2.3, "Solenoid voltage and version"

LSODE.. (rising characteristic line)

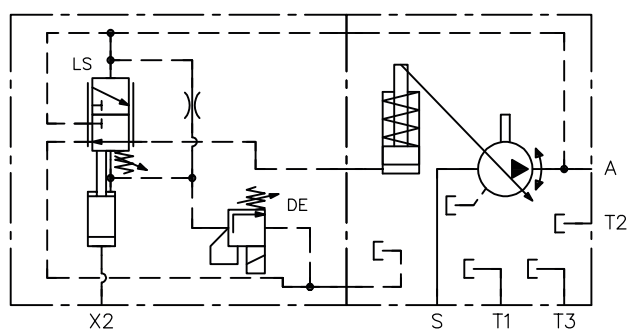

LS2DE.. (rising characteristic line)

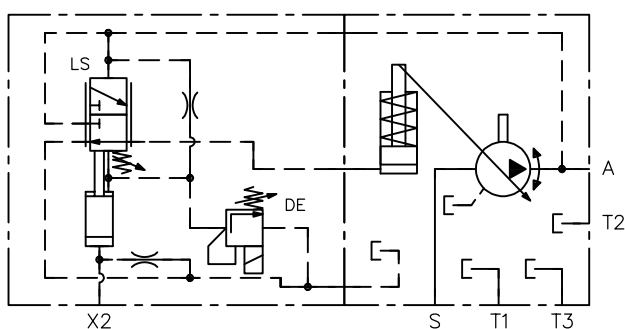

LSODE.. (falling characteristic line)

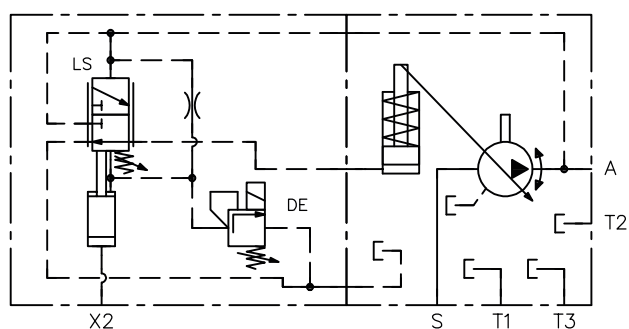

LS2DE.. (falling characteristic line)

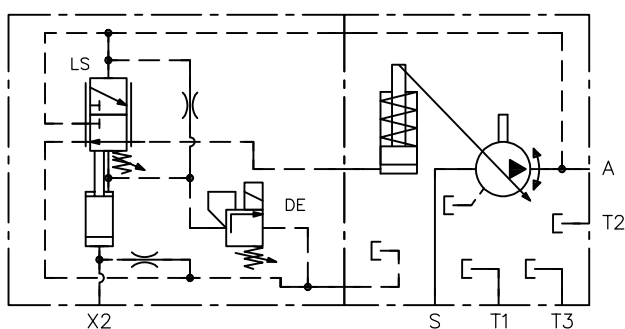

characteristic lines for LS0DE.., LS2DE..

**LS function**

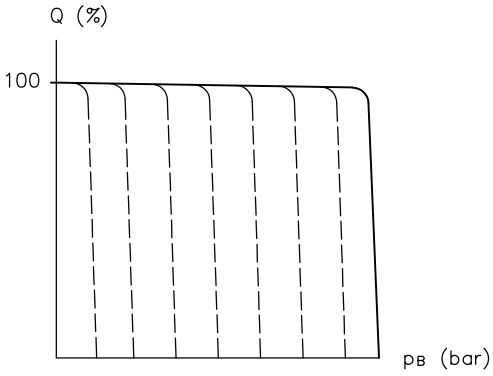

$p_B$  operating pressure (bar);  $Q$  delivery flow (%)

**DE function (rising characteristic line)**

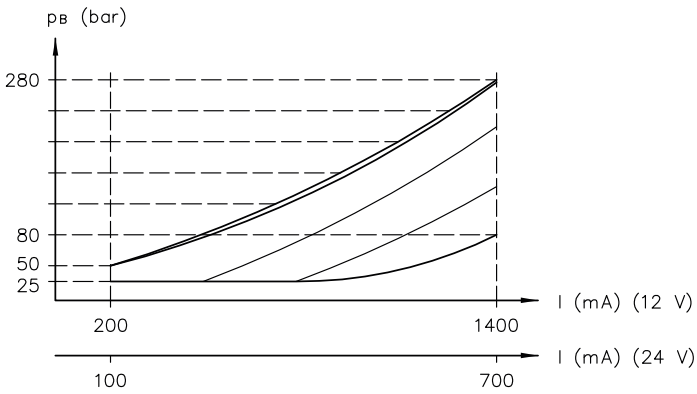

$I$  control current (mA);  $p_B$  operating pressure (bar)

**DE function (falling characteristic line)**

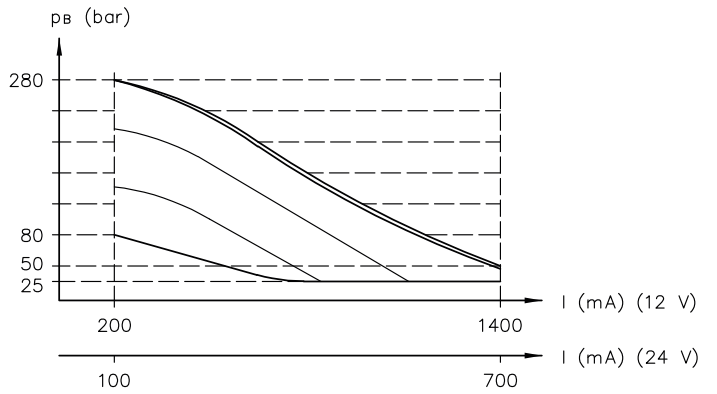

$I$  control current (mA);  $p_B$  operating pressure (bar)

**Relationship between standby pressure and max. pressure at  $I_{max}$**

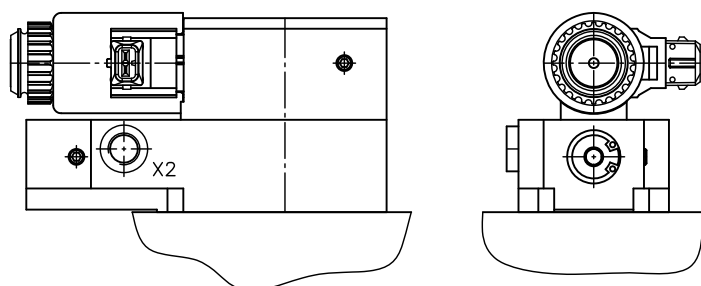
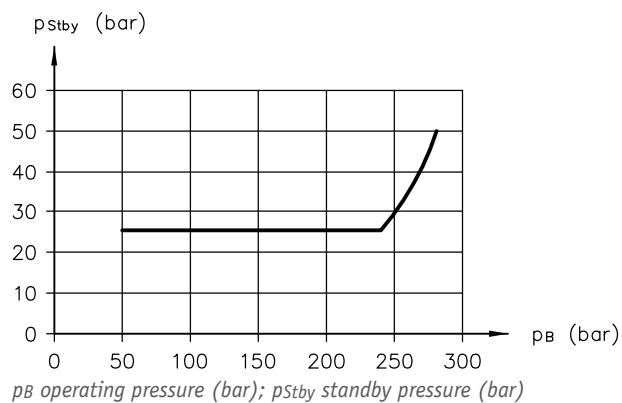

**Pressure adjustment**

Adjustment range $p_{max}$ (bar)	Resulting range $p_{min}$ (bar)	Resulting standby pressure with a setting value of $\Delta p = 20$ bar
80 - 280	25 - 50	25 - 50

### 2.2.3 Pressure controller DF-DA

The DF-DA controller consists of two parts. The 'DA' part is responsible for setting the maximum pressure. As soon as the pump pressure exceeds the set value, they reduce the swivel angle of the pump and regulate a constant pressure level. The pressure setting is adjusted using an adjusting screw on the controller, and, in addition, an external pilot valve can be connected to the X5 port to enable remote adjustment when necessary. If an external pressure-limiting valve has been connected to the X5 port, the 'DF' part will regulate a constant pressure level that is below the maximum pressure setting from the 'DA' part.

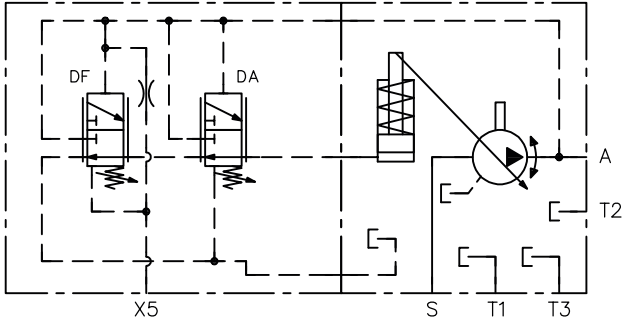

#### Characteristic lines

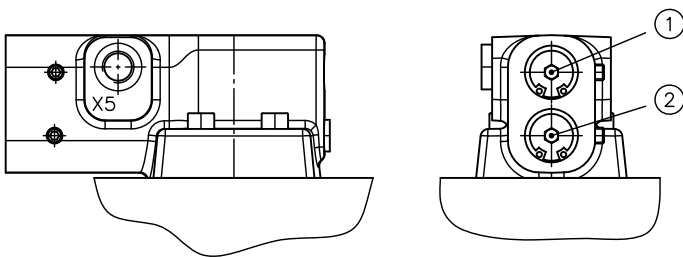
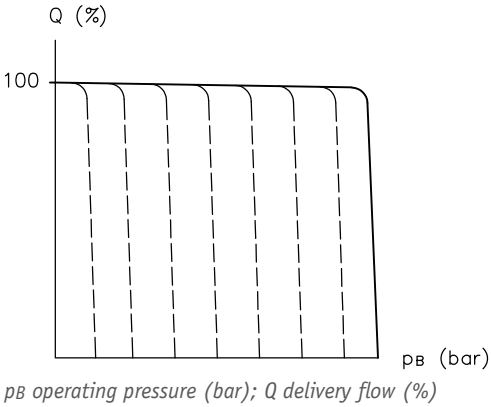

- 1 DF setting screw
- 2 DA setting screw

#### Pressure adjustment

Pressure adjustment	Pressure range (bar)	$\Delta p$ (bar)/revolution	Factory-set pressure setting (bar)
Maximum pressure $p_{max}$	150 ... 280	105	250

## 2.2.4 Pressure controller DE..

The DE controller is an electro-proportional pressure controller. As soon as the pump pressure exceeds the set value, the controller reduces the swivel angle of the pump and regulates a constant pressure level.

The minimum and maximum pressures are set mechanically on the controller. In between these values, the pressure can be adjusted proportionally using an electrical signal.

**Solenoid voltage and version:** see Chapter 2.3, "Solenoid voltage and version"

**DE1/3/5/7** (rising characteristic line)

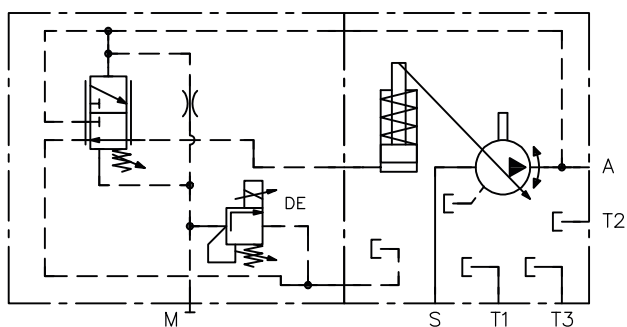

**DE2/4/6/8** (falling characteristic line)

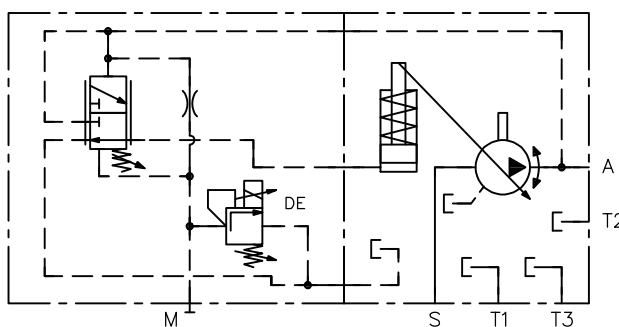

## Characteristic lines

**DE1/3/5/7** (rising characteristic line)

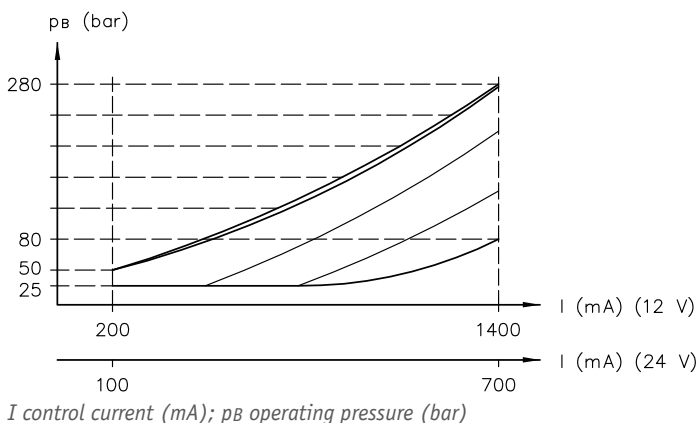

**DE2/4/6/8** (falling characteristic line)

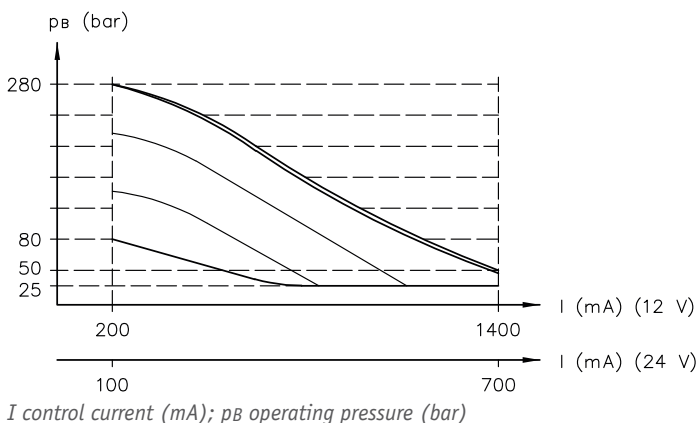

**Relationship between standby pressure and max. pressure at  $I_{max}$**

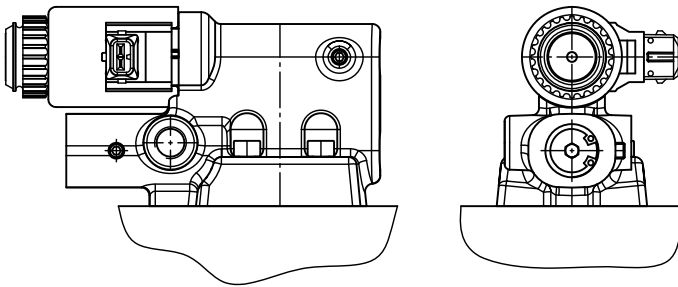
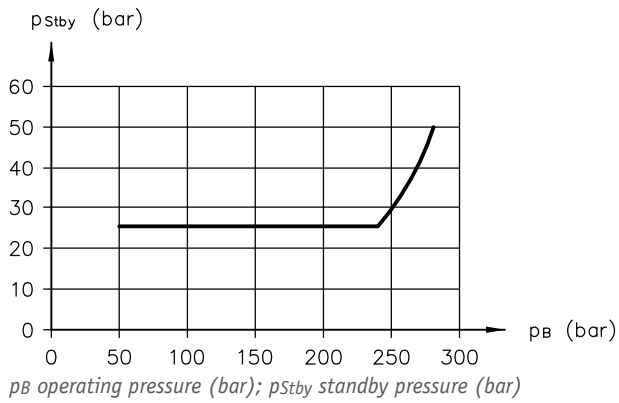

**Pressure adjustment**

Adjustment range $p_{max}$ (bar)	Resulting range $p_{min}$ (bar)	Resulting standby pressure with a setting value of $\Delta p = 20$ bar
80 - 280	25 - 80	25 - 50

## 2.2.5 Flow controller VE..

The VE controller is an electro-proportional flow controller that generates a variable flow rate depending on the speed. It adjusts the geometric displacement of the pump based on an electrical input signal. The resulting flow rate depends on the displacement volume and speed.

The VE controller is only available with a rising characteristic line and in combination with a pressure controller.

The required pilot pressure for adjusting the swivel angle is tapped internally. When used in open centre systems with operating pressures of < 10 bar, an external auxiliary pump or a pre-load valve must be provided to ensure reliable adjustment.

If the pressure is > 10 bar and the control current  $I$  is < 230 mA, the axial piston unit will pivot to  $V_{g \text{ min}}$ . With a rising control current  $I$  of > 230 mA, it can then be pivoted to any desired angle.  $V_{g \text{ max}}$  is achieved at control current  $I = 440 \text{ mA}$ .

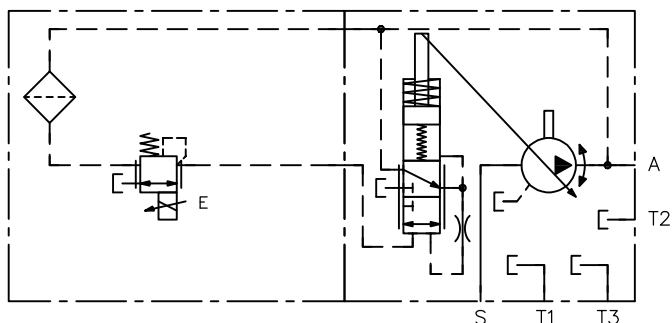

### Characteristic lines

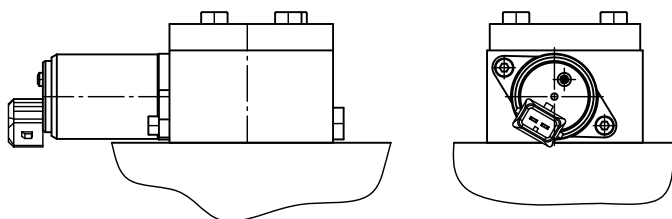
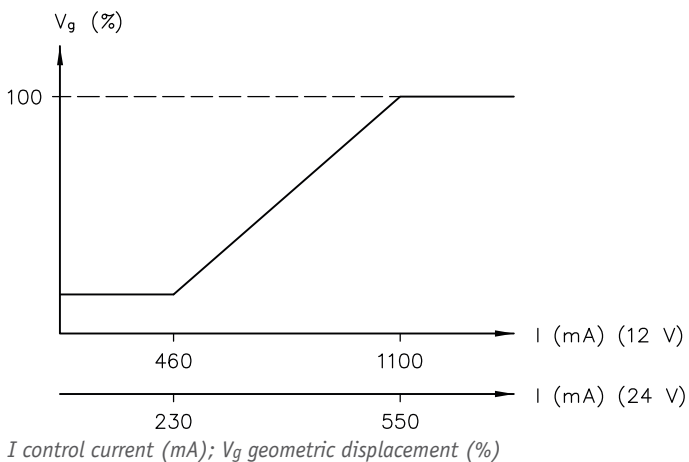

## 2.2.6 Power controller LR

The LR controller is a power controller with a fixed setting value. When the product of displacement volume times pressure exceeds the set value, the controller reduces the pump's swivel angle. This protects the drive shaft, motor or gearbox from overloading ( $p_B \times V_g = \text{constant}$ ).

The power controllers are only available in combination with a pressure- or load-sensing controller.

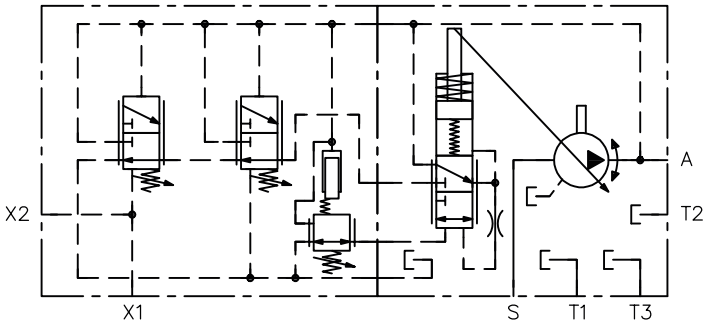

### Characteristic lines

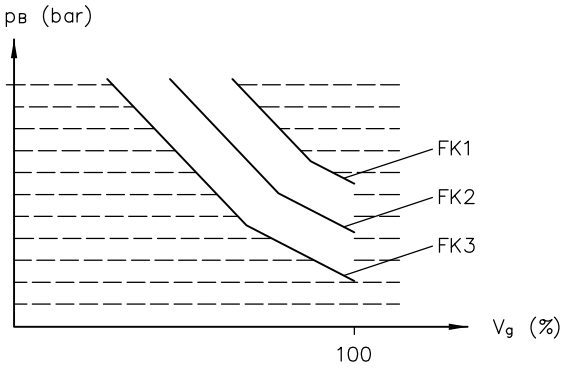

$V_g$  geometric displacement (%);  $p_B$  operating pressure (bar)

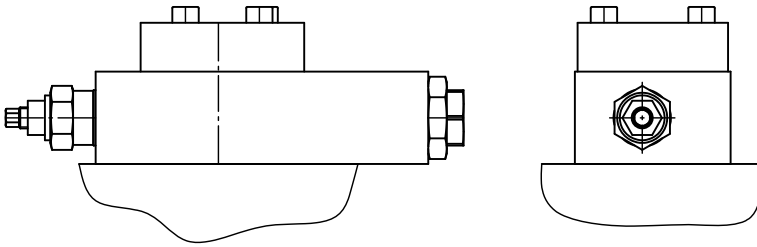



## 2.3 Solenoid voltage and version

Coding	Description	Voltage	Plug
1	Rising characteristic line	24 V	Deutsch plug
2	Falling characteristic line		
3	Rising characteristic line	12 V	
4	Falling characteristic line		
5	Rising characteristic line	24 V	AMP plug
6	Falling characteristic line		
7	Rising characteristic line	12 V	
8	Falling characteristic line		

### **i** INFORMATION

In the case of flow controller VE., only rising characteristic lines are available (coding 1, 3, 5, 7).

## 2.4 Seals

Coding	Description
V	Viton

## 2.5 Rotation direction

Coding	Description
L	Anti-clockwise
R	Clockwise

## 2.6 Flange versions (input side)

Coding	Description	Designation	for
B2	Flange	SAE-B 2-hole J744 101-2 DIN 3019-1	C40V-028, C40V-045
C6	Flange	SAE-C 2+4-hole (similar to J744) 127-2 and 127-4 DIN 3019-1	C40V-085

## 2.7 Shaft journal

Coding	Description	Designation / standard	for	Max. drive torque (Nm)
A2	Spline shaft	SAE-B J744 13T 16/32 DP 22-4 DIN ISO 3019-1	C40V-028, C40V-045	280
A4	Spline shaft	SAE-BB J744 15T 16/32 DP 25-4 DIN ISO 3019-1	C40V-045	447
A6	Spline shaft	SAE-C J744 14T 12/24 DP 32-4 DIN ISO 3019-1	C40V-085	785
A0	Spline shaft	SAE-CC J744 17T 12/24 DP 38-4 DIN ISO 3019-1	C40V-085	1478

## 2.8 Housing versions

Coding	Description	for	Designation / standard
A1	Suction and pressure connection radial, with thru-shaft	C40V-085	ISO 6162-2 SAE J518-2
A3	Suction and pressure connection axial	C40V-085	ISO 6162-2 SAE J518-2
B1	Suction and pressure connection radial, with thru-shaft	C40V-028, C40V-045	ISO 6162-1 SAE J518-1
B3	Suction and pressure connection axial	C40V-028, C40V-045	ISO 6162-1 SAE J518-1

## 2.9 Thru-shaft

Coding	Flange	Shaft
0000	Without thru-shaft, only in combination with housing version coding A3 or B3	
K02G	Prepared for thru-shaft, sealed with cover	
<b>Flange versions (output side)</b>		
A11D	SAE-A 2-hole J744 82-2 DIN ISO 3019-1	SAE-A J744 (16-4 DIN ISO 3019-1) 9T 16/32 DP
A21D	SAE-A 2-hole J744 82-2 DIN ISO 3019-1	19-4 DIN ISO 3019-1 11T 16/32 DP
B11D	SAE-B 2-hole J744 101-2 DIN ISO 3019-1	SAE-B J744 (22-4 DIN ISO 3019-1) 13T 16/32 DP
B21D	SAE-B 2-hole J744 101-2 DIN ISO 3019-1	SAE-BB J744 (25-4 DIN ISO 3019-1) 15T 16/32 DP
C11D	SAE-C 2-hole J744 127-2 DIN ISO 3019-1	SAE-C J744 (32-4 DIN ISO 3019-1) 14T 12/24 DP
C21D	SAE-C 2-hole J744 127-2 DIN ISO 3019-1	SAE-CC J744 (38-4 DIN ISO 3019-1) 17T 12/24 DP

### **i** INFORMATION

- SAE-BB only for nominal size 045 and 085
- SAE-C/SAE-CC only for nominal size 085

## 2.10 Pivoting angle of stops

Coding	Description
0	No stop
5	With $Q_{max}$ stop, fixed (please state when placing the order)

## 2.11 Special versions and options

Coding	Description
G	Priming

## 3 Parameters

### 3.1 General data

<b>Designation</b>	Variable displacement axial piston pump				
<b>Design</b>	Axial piston pump according to the swash plate principle				
<b>Mounting</b>	DIN ISO 3019-1, SAE J744				
<b>Surface</b>	primed				
<b>Drive/output torque</b>	max. permissible drive/output torque (Nm)				
	<b>Nominal size</b>				
	<b>028</b>	<b>045</b>	<b>085</b>	<b>100</b>	
<b>Spline shaft A2</b>	280 / 158	280 / 300	--	--	
<b>Spline shaft A4</b>	--	447 / 300	--	--	
<b>Spline shaft A6</b>	--	--	785 / 532	785 / 532	
<b>Spline shaft A0</b>	--	--	1478 / 532	1478 / 532	
<b>Installation position</b>	any Installation information see Chapter 5, "Installation, operation and maintenance information"				
<b>Rotation direction</b>	Clockwise or anticlockwise				
<b>Ports/connections</b>	<ul style="list-style-type: none"> <li>▪ Suction port</li> <li>▪ Pressure connection</li> <li>▪ Drain port</li> <li>▪ Pressure gauge connection</li> <li>▪ LS port</li> </ul>				
<b>Hydraulic fluid</b>	Hydraulic fluid, according to DIN 51 524 Parts 1 to 3; ISO VG 10 to 68 according to DIN ISO 3448 Viscosity range: 8 - 500 mm <sup>2</sup> /s Optimal operating range: approx. 16 - 36 mm <sup>2</sup> /s see Chapter 5.3, "Operating instructions" Also suitable for biologically degradable hydraulic fluids type HEPG (polyalkylene glycol) and HEES (synthetic ester) at operating temperatures up to approx. +70°C.				
<b>Cleanliness level</b>	<b>ISO 4406</b> <hr style="width: 20%; margin-left: 0;"/> 19/17/14				
<b>Temperatures</b>	Environment: approx. -40 to +60 °C, hydraulic fluid: -25 to +80 °C, pay attention to the viscosity range. Start temperature: down to -40 °C is permissible (take account of the start viscosities!), as long as the steady-state temperature is at least 20 K higher during subsequent operation. Biologically degradable hydraulic fluids: note manufacturer specifications. With consideration for the seal compatibility, not above +70°C.				

Designation	Nominal size				
	028	045	085	100	
Max. swash plate angle	18°	18°	18°	18°	
Absolute inlet pressure required in open circuit	bar	0.85	0.85	0.85	
Max. permissible housing pressure (static/dynamic)	bar	2	2	2	
Max. permissible inlet pressure (static/dynamic)	bar	2	2	2	
Max. speed during suction operation and max. swash plate angle at 1 bar abs. Inlet pressure	rpm	3300	3000	2500	2400
Min. speed in continuous operation	rpm	100	100	100	100
Required drive torque at $V_{g \max}$ and $\Delta p = 280$ bar	Nm	127.9	207.2	383.7	461,1
Drive power at $V_{g \max}$ , $n_{\max}$ and $\Delta p = 280$ bar	kW	44,2	65,1	96,4	115,9
Inertia torque	kg m <sup>2</sup>	0.002	0.004	0,0097	0,0128

### Adjustment times

The table shows the time required to swing the pump from minimum to maximum displacement volume at 200 bar and 1500 rpm (on-stroke time) and to swing it back from maximum to minimum output volume (destroke time).

Size	On-stroke time (ms)	Destroke time (ms)
028	73	49
045	139	40
085	164	84
100	267	130

## 3.2 Weight

	Nominal size	Basic pump (kg)		With controller (kg)				
		Axial connections	Radial connections	LS..DA	LS..DE..	DE..	VE..	LR
	028	14,6	16,2	+1.4	+2.1	+1.7	+1.3	+2.3
	045	19,6	21,3	+1.4	+2.1	+1.7	+1.3	+2.3
	085	37,6	40,1	+1.4	+2.1	+1.7	+1.35	+2.35
	100	38,9	42,5	+1.4	+2.1	+1.7	+1.35	+2.35

## 3.3 Pressure and delivery flow

Operating pressure	see Chapter 2, "Available versions"
Displacement volume	see Chapter 2, "Available versions"

### 3.4 Characteristic lines

#### Delivery flow

The diagrams show delivery flow over pressure without a controller at 1500 rpm.

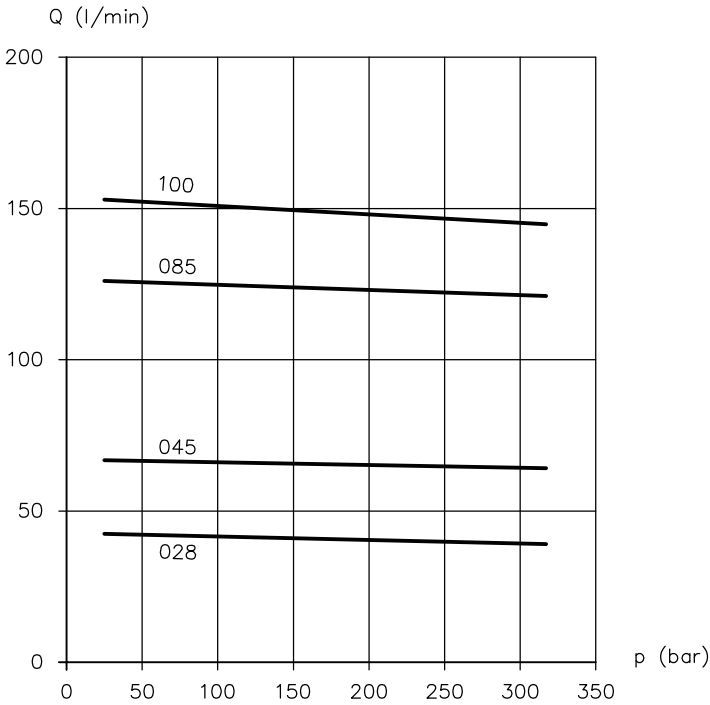

p pressure (bar); Q delivery flow (lpm); P power (kW)

- 1 Delivery flow/pressure
- 2 Drive power/pressure (max. swash plate angle)

### 3.5 Electrical data

#### Controller coding DE..

Nominal voltage	12 V DC	24 V DC
Resistance R <sub>20</sub>	6.0 - 6.4 Ω	24.4 - 26.2 Ω
Current, cold I <sub>20</sub>	1400 mA	700 mA
Power P	18.3 W	18.7 W
Duty cycle	S1 (100 %)	
Dither frequency	100 - 200 Hz	
Dither amplitude $A_D(\%) = \frac{I_{Peak-Peak}}{I_G} \cdot 100$	20% ≤ A <sub>D</sub> ≤ 40%	
Permissible ambient temperature	-20°C to +80°C	
Protection class in accordance with DIN VDE 0470 when mounted and plugged in	max. IP 65	

#### Controller coding VE..

Nominal voltage	12 V DC	24 V DC
Resistance R <sub>20</sub>	4.98 - 5.62 Ω	20.68 - 23.32 Ω
Current, cold I <sub>20</sub>	1500 mA	750 mA
Power P	18.3 W	18.7 W
Duty cycle	S1 (100 %)	
Dither frequency	100 - 200 Hz	
Dither amplitude $A_D(\%) = \frac{I_{Peak-Peak}}{I_G} \cdot 100$	20% ≤ A <sub>D</sub> ≤ 40%	
Permissible ambient temperature	-30°C to +90°C	
Protection class in accordance with DIN VDE 0470 when mounted and plugged in	max. IP 67	

#### Electrical connection

##### Coding AMP

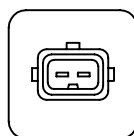
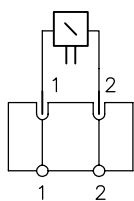

##### Coding DT

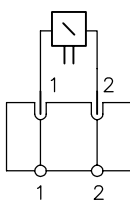

## 4 Dimensions

All dimensions in mm, subject to change.

### 4.1 Basic pump

#### 4.1.1 C40V-028

Rotation direction clockwise (view: shaft journal)

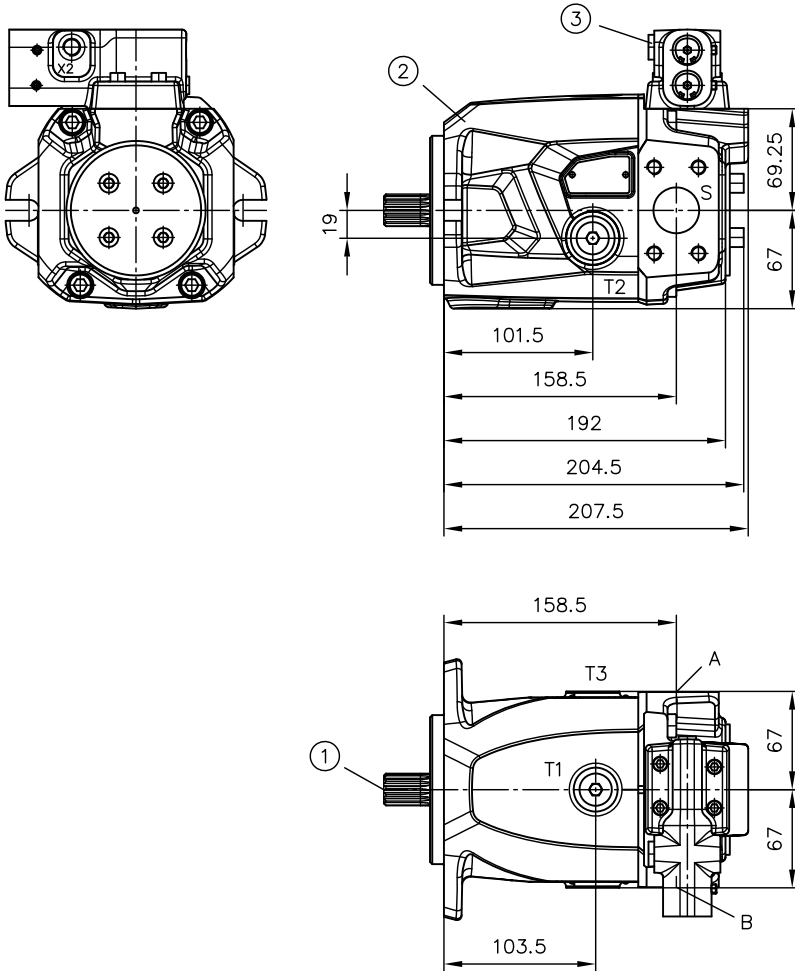

Rotation direction anti-clockwise (view: shaft journal)

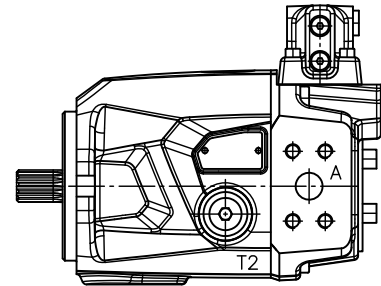

- 1 Shaft version
- 2 Flange version
- 3 Controller



**Working connection A**

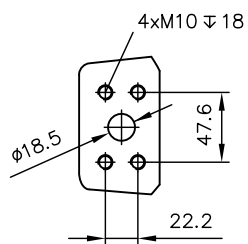

**Suction port S**

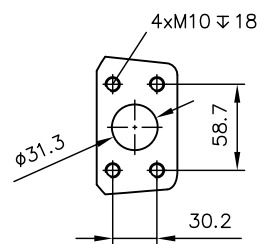

**Ports (ISO 11926)**

T1, T2, T3

Drain port 3/4-16 UNF-2B

**Shaft journal**

**A2**

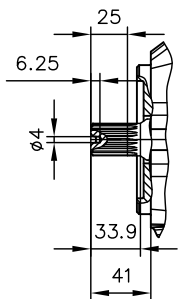

**Housing version B1**

**K02G**

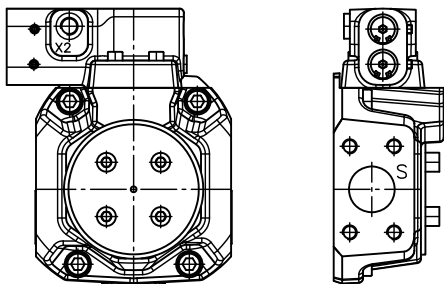

Flange versions (output side)

**A11D**

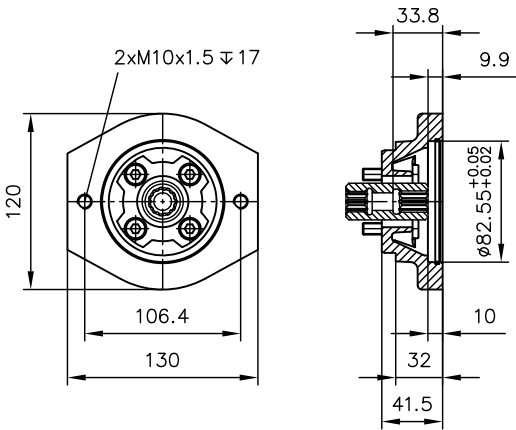

**A21D**

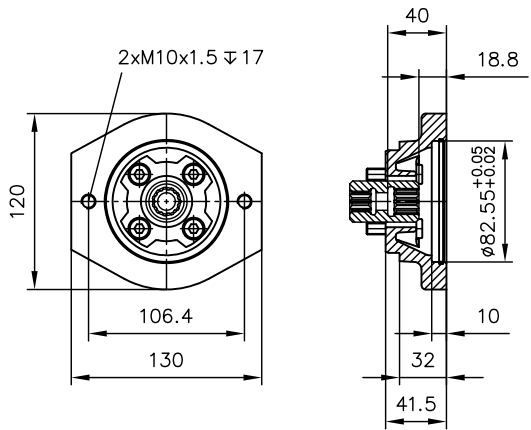

**B11D**

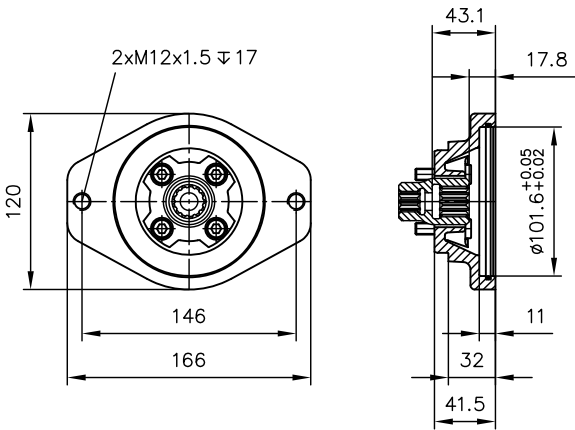

**Housing version B3**

Rotation direction clockwise (view: shaft journal)

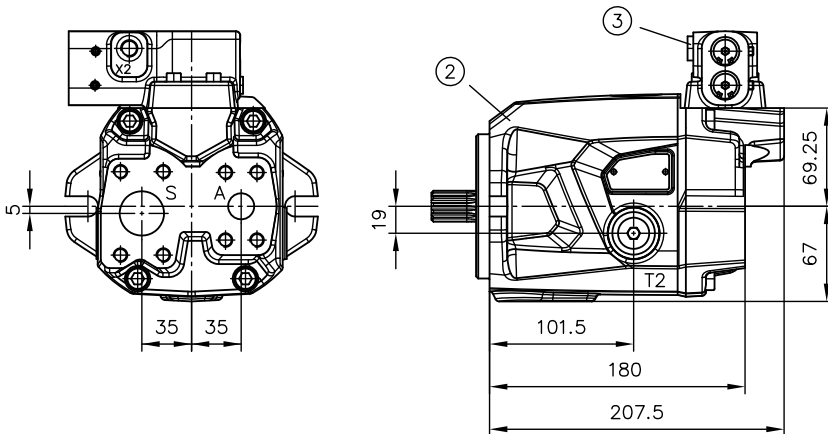

Rotation direction anti-clockwise (view: shaft journal)

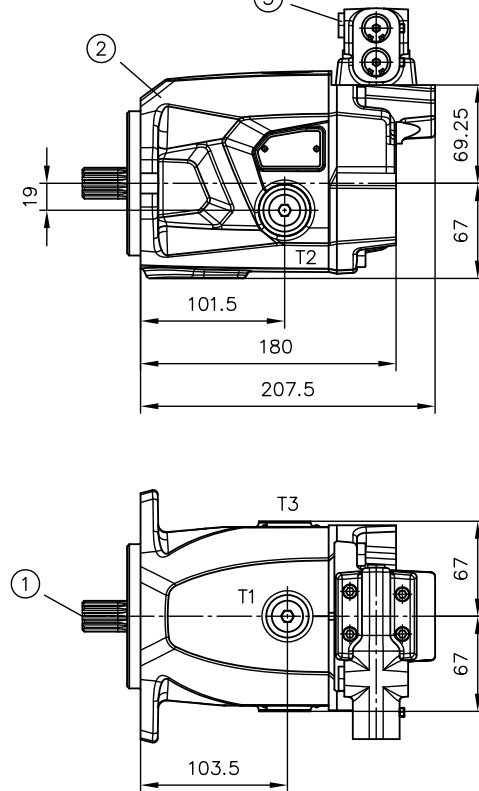

- 1 Shaft version
- 2 Flange version
- 3 Controller

**Working connection A**  
**Suction port S**

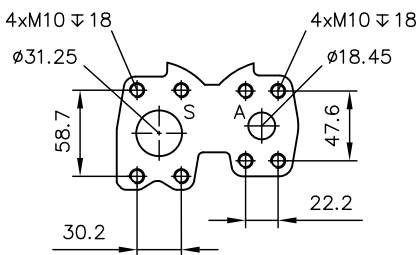

**Ports (ISO 11926)**

T1, T2, T3 Drain port 3/4-16 UNF-2B

**4.1.2 C40V-045**

Rotation direction clockwise (view: shaft journal)

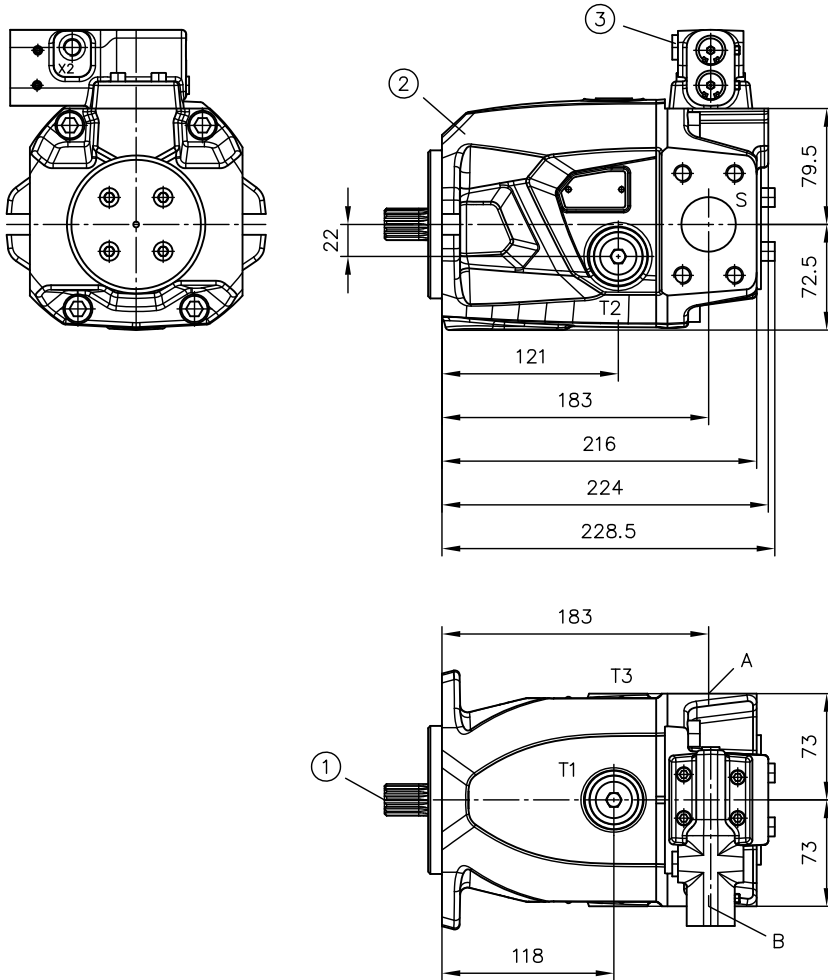

Rotation direction anti-clockwise (view: shaft journal)

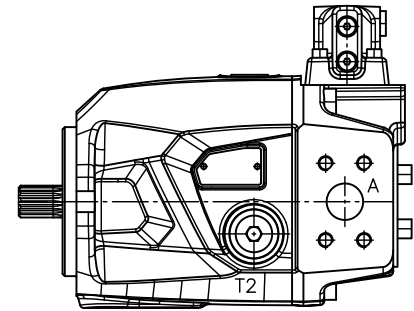

- 1 Shaft version
- 2 Flange version
- 3 Controller

**Working connection A**

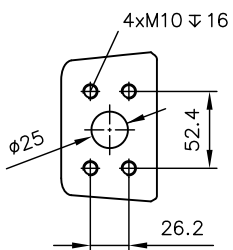

**Suction port S**

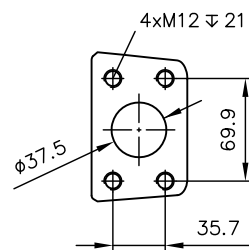

**Ports (ISO 11926)**

T1, T2, T3

Drain port 7/8-14 UNF-2B

**Shaft journal**

A2

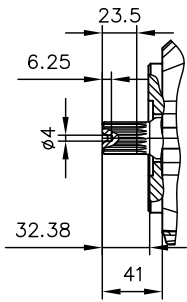

A4

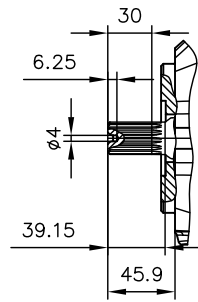

**Housing version B1**

K02G

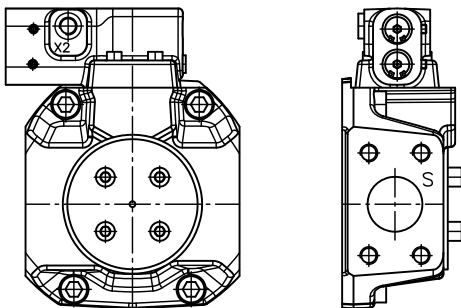

Flange versions (output side)

A11D

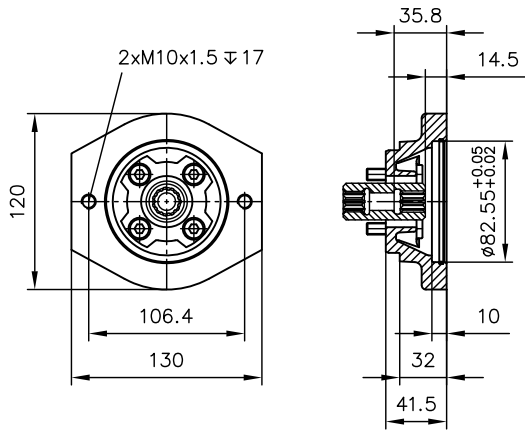

A21D

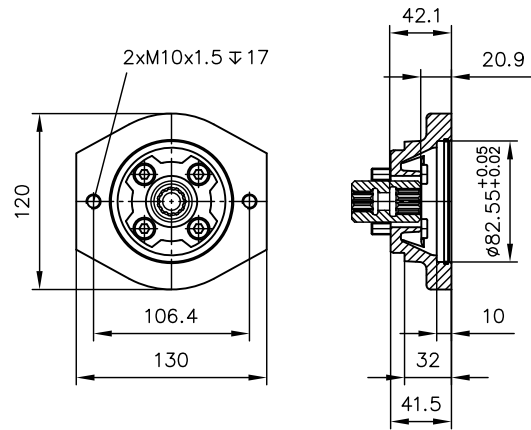

B11D

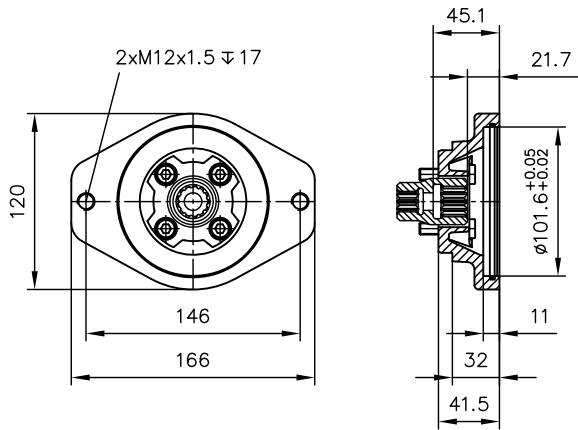

B21D

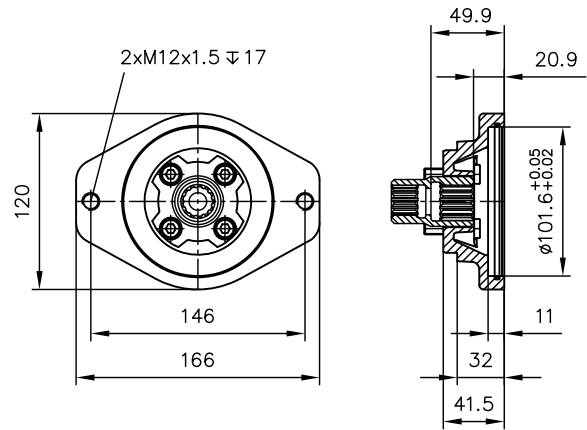

**Housing version B3**

Rotation direction clockwise (view: shaft journal)

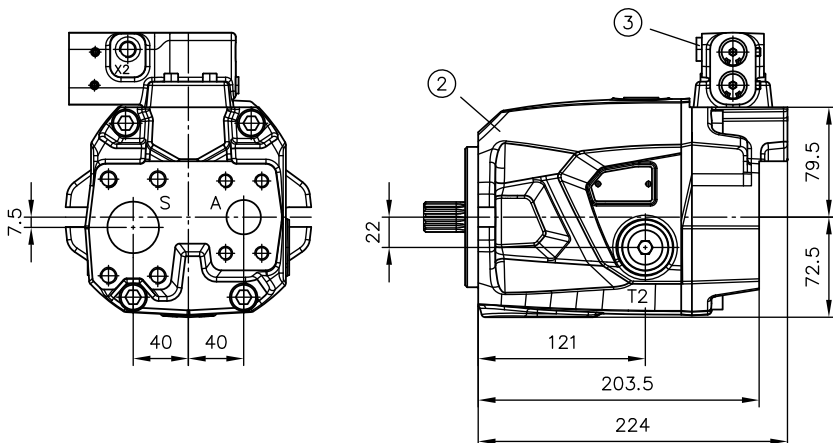

Rotation direction anti-clockwise (view: shaft journal)

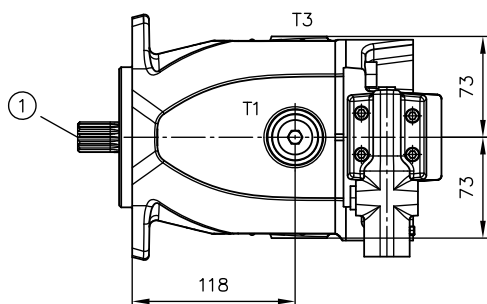
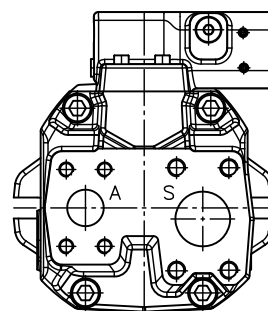

- 1 Shaft version
- 2 Flange version
- 3 Controller

**Working connection A**

**Suction port S**

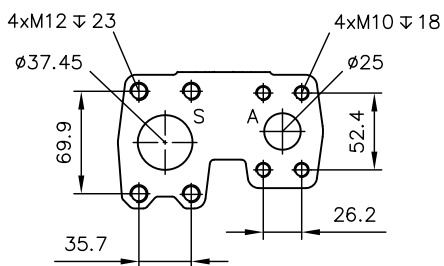

**Ports (ISO 11926)**

T1, T2, T3

Drain port 7/8-14 UNF-2B

**4.1.3 C40V-085**

Rotation direction clockwise (view: shaft journal)

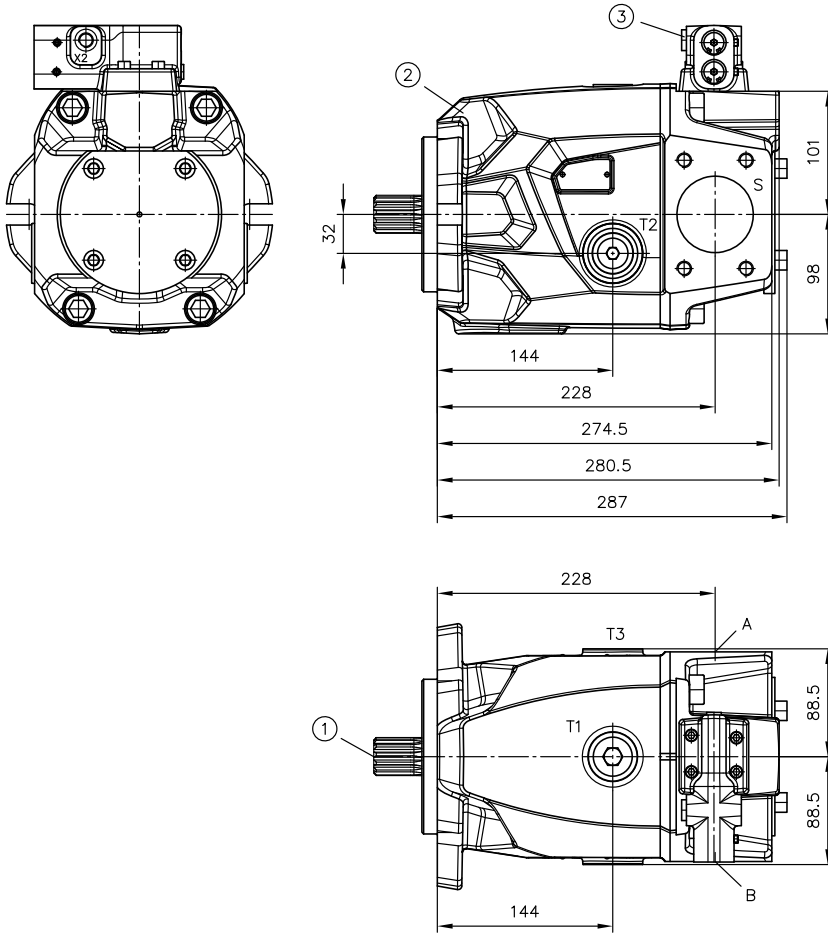

- 1 Shaft version
- 2 Flange version
- 3 Controller

Rotation direction anti-clockwise (view: shaft journal)

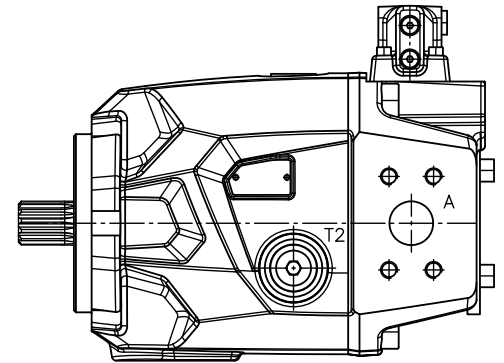

Working connection A

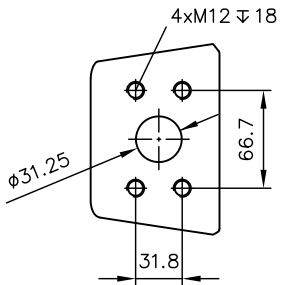

Suction port S

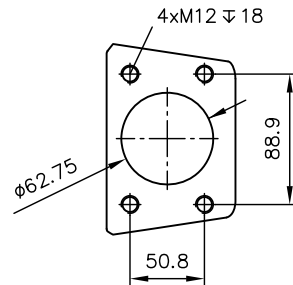

**Ports (ISO 11926)**

T1, T2, T3

Drain port 1 1/16-12 UNF-2B



**Shaft journal**

A6

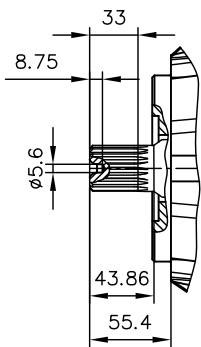

A0

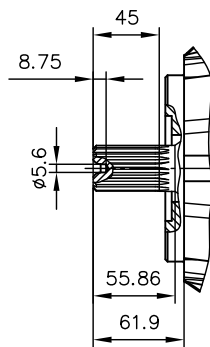

**Housing version A1**

K02G

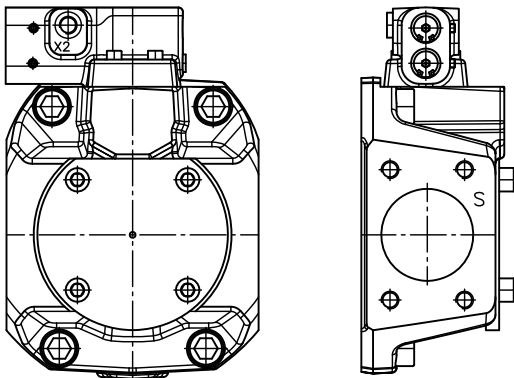

Flange versions (output side)

A11D

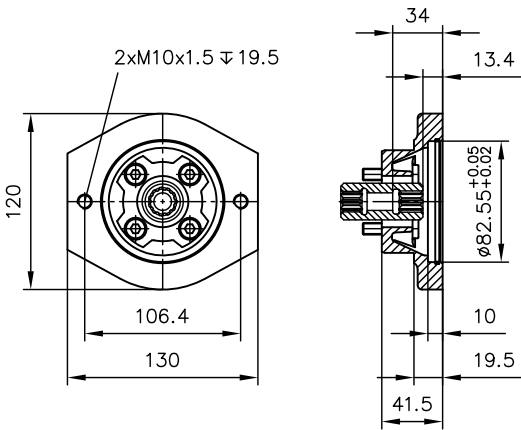

A21D

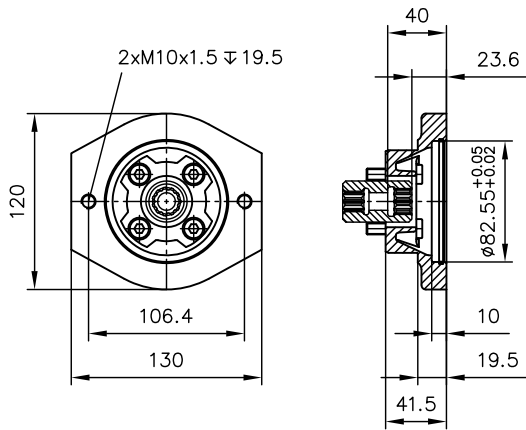

B11D

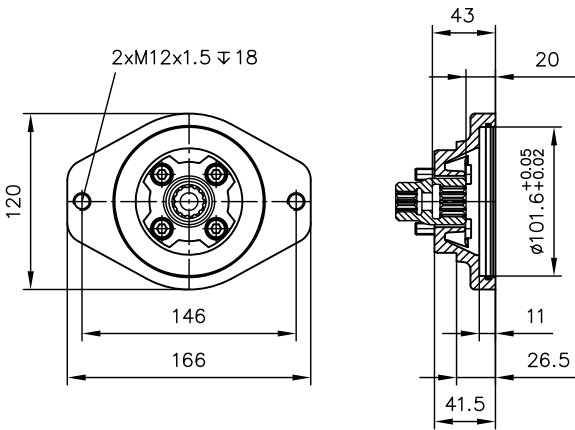

B21D

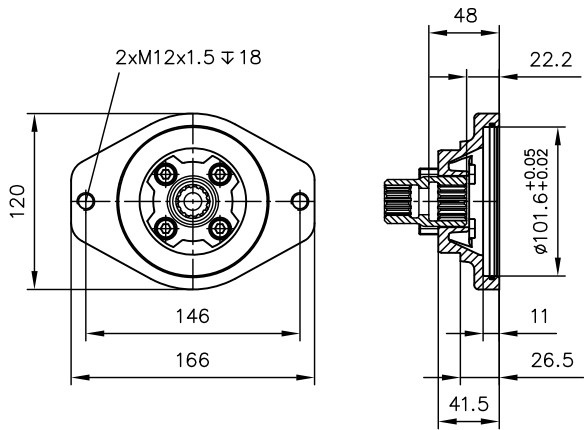

C11(12)D

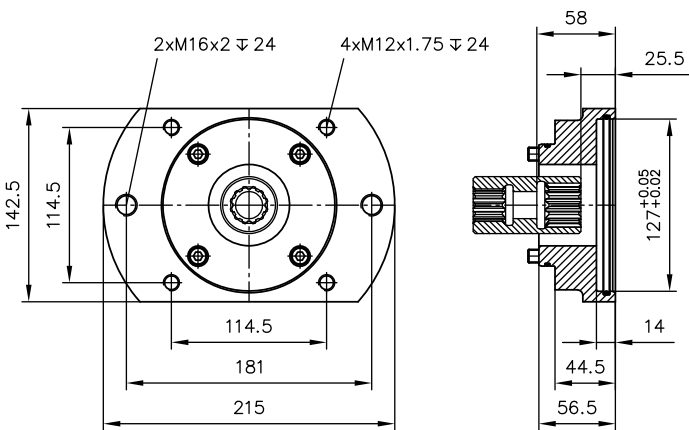

C21(22)D

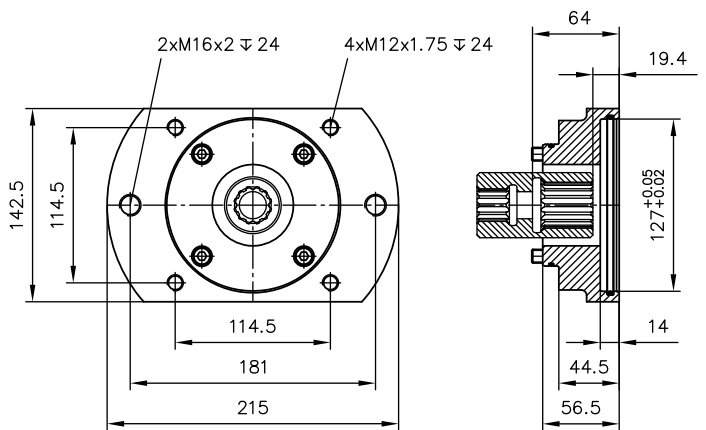

**Housing version A3**

Rotation direction clockwise (view: shaft journal)

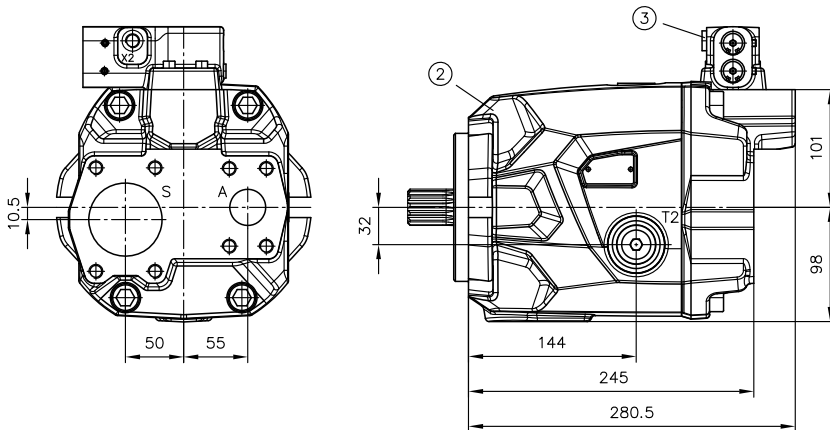

Rotation direction anti-clockwise (view: shaft journal)

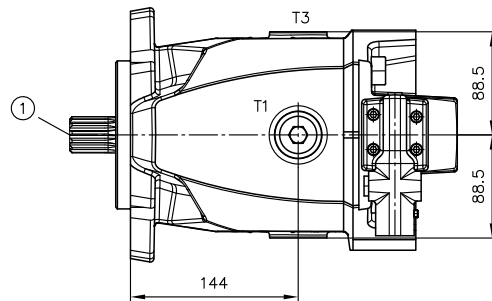
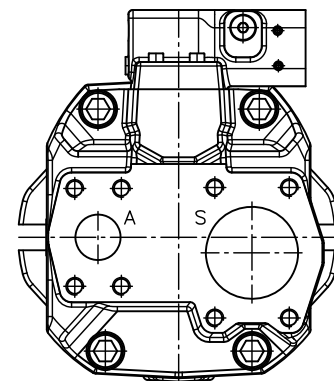

- 1 Shaft version
- 2 Flange version
- 3 Controller

**Working connection A**  
**Suction port S**

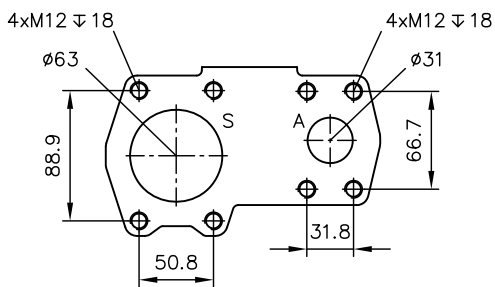

**Ports (ISO 11926)**

T1, T2, T3

Drain port 1 1/16-12 UNF-2B

**4.1.4 C40V-100**

Rotation direction clockwise (view: shaft journal)

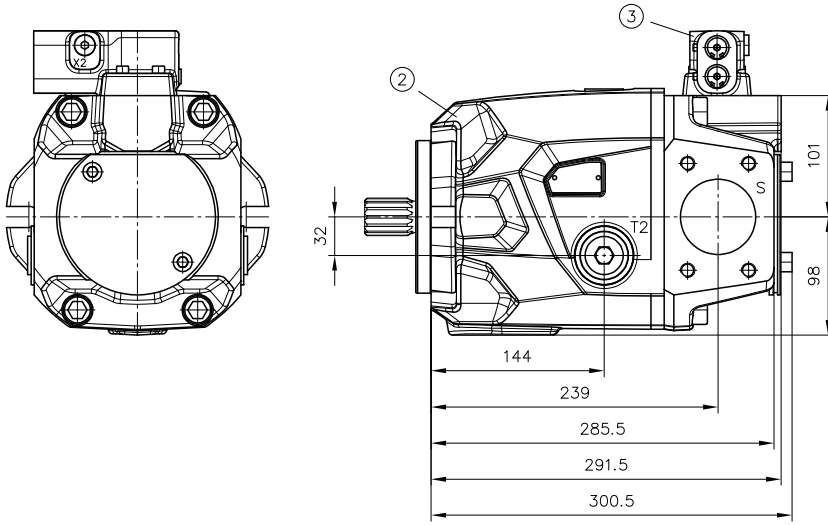

Rotation direction anti-clockwise (view: shaft journal)

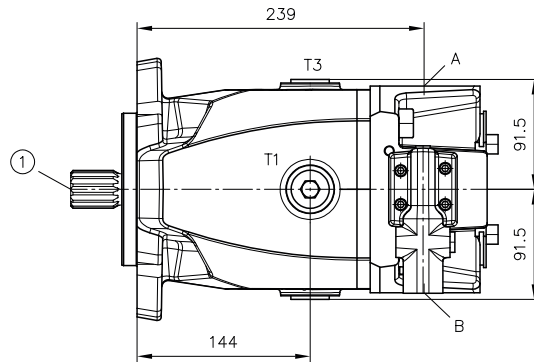
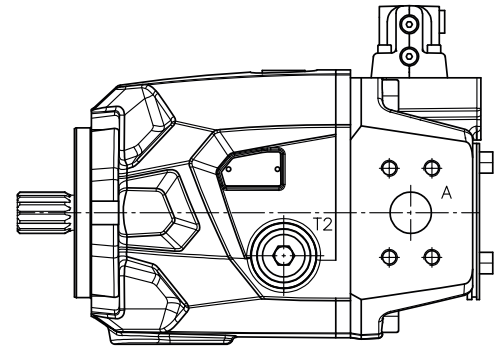

- 1 Shaft version
- 2 Flange version
- 3 Controller

Working connection A

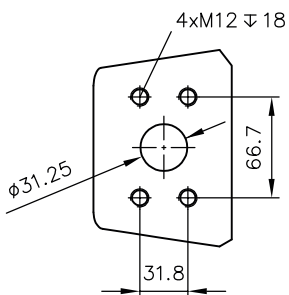

Suction port S

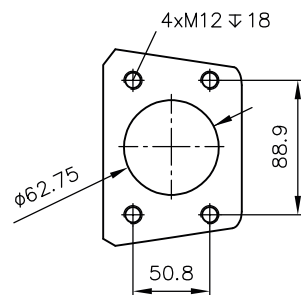

**Shaft journal**

A6

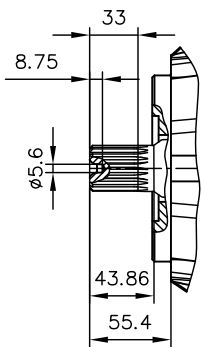

A0

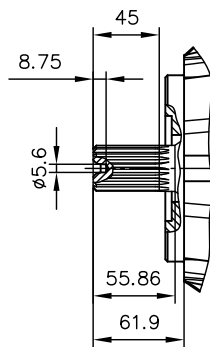

**Housing version A1**

K02G

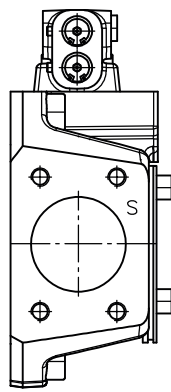
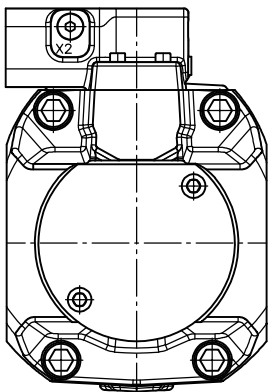

Flange versions (output side)

A11D

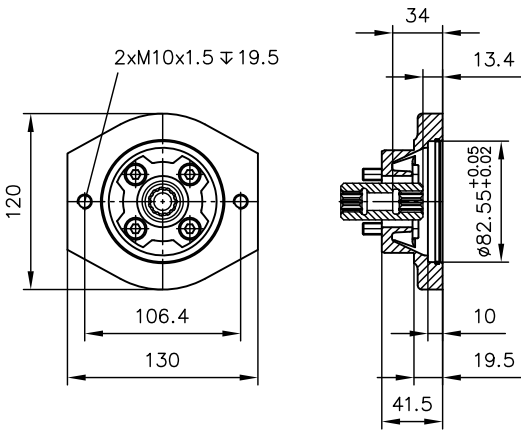

A21D

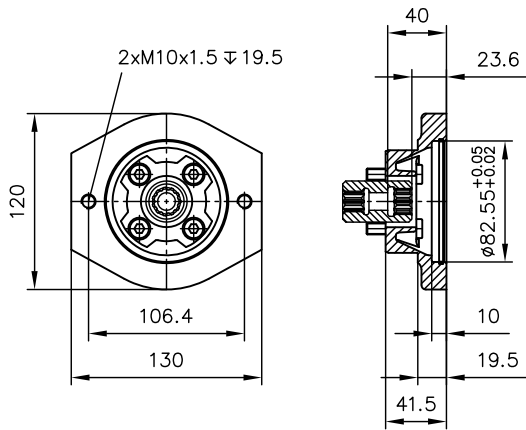

B11D

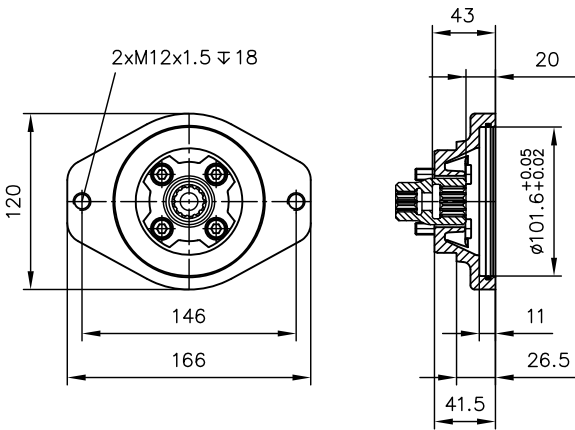

B21D

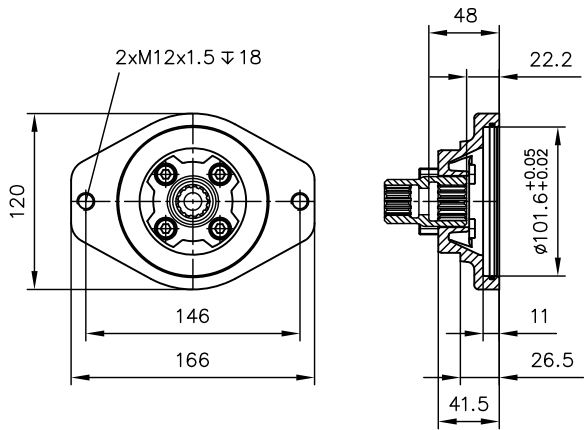

C11(12)D

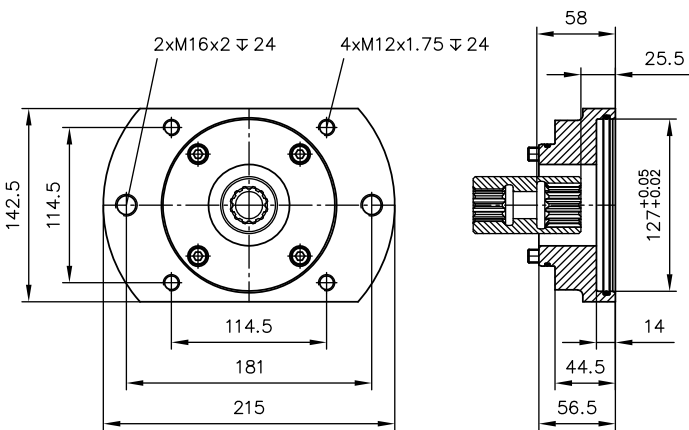

C21(22)D

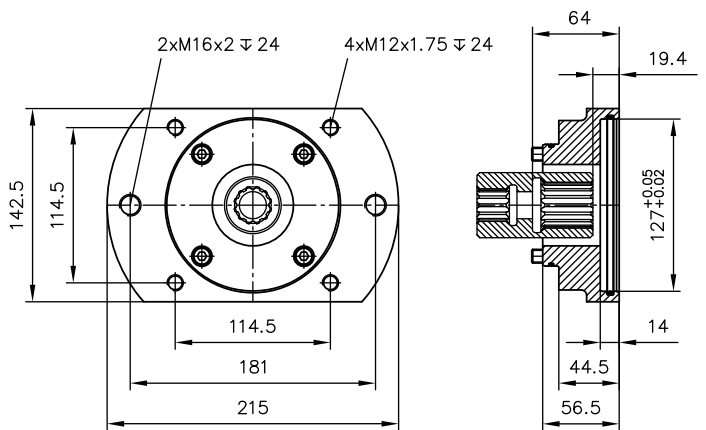

**Housing version A3**

Rotation direction clockwise (view: shaft journal)

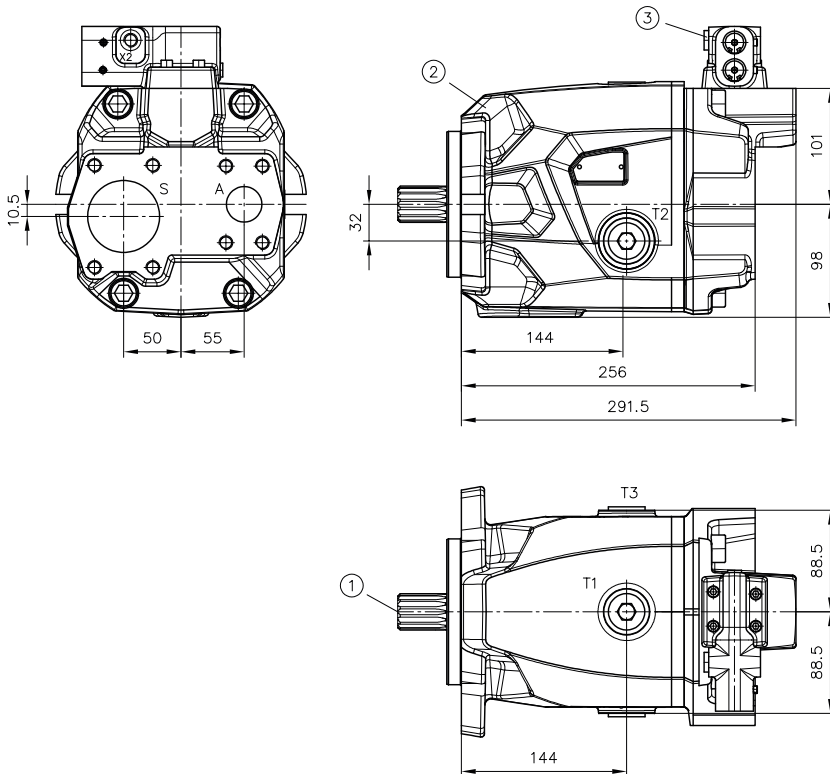

Rotation direction anti-clockwise (view: shaft journal)

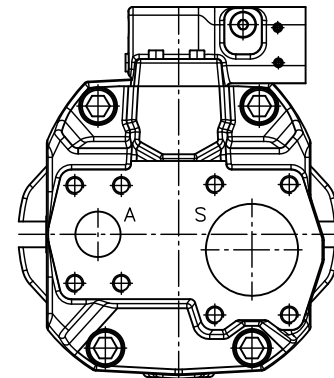

- 1 Shaft version
- 2 Flange version
- 3 Controller

## 4.2 Controllers

### LSODA, LS2DA

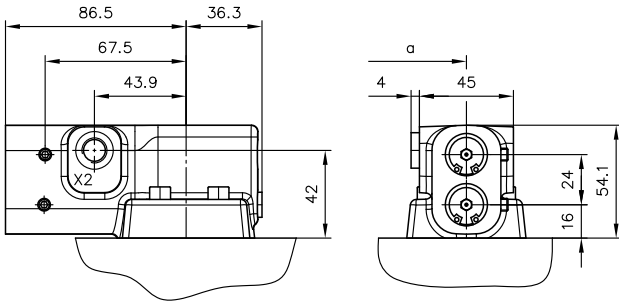

### LSODE., LS2DE..

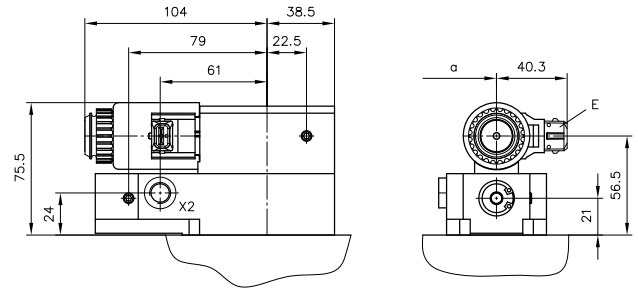

### DF-DA

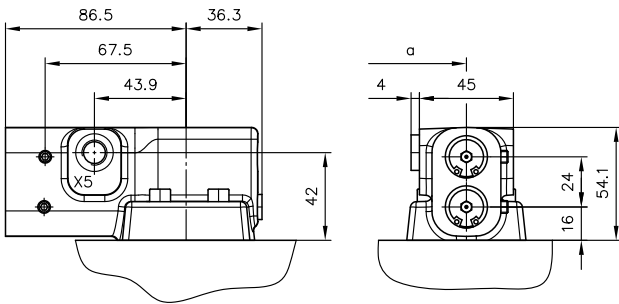

### DE..

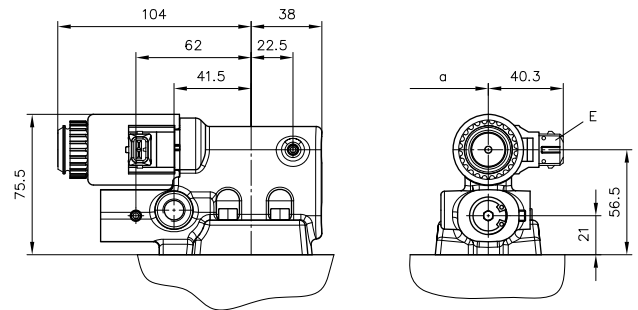

Type	a
C40V-028	166
C40V-045	184,5
C40V-085	227

### VE..

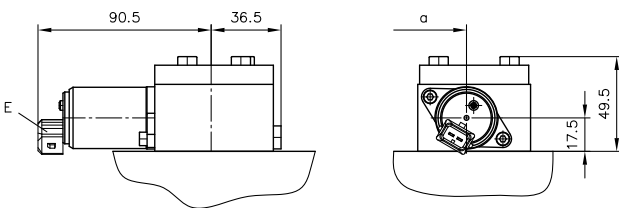

### LR

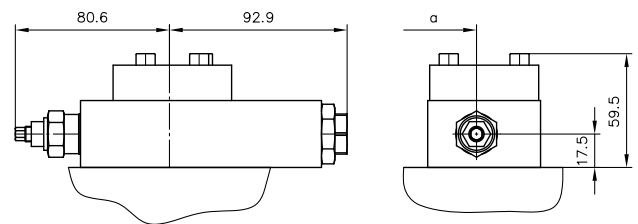

Type	a
C40V-028	165,6
C40V-045	182
C40V-085	237,4



**5****Installation, operation and maintenance information**

Observe the document B 5488 "General operating instructions for assembly, commissioning, and maintenance."

**5.1 Intended use**

This product is intended exclusively for hydraulic applications (fluid technology).

The user must observe the safety measures and warnings in this document.

**Essential requirements for the product to function correctly and safely:**

- ▶ All information in this documentation must be observed. This applies in particular to all safety measures and warnings.
- ▶ The product must only be assembled and put into operation by specialist personnel.
- ▶ The product must only be operated within the specified technical parameters described in detail in this document.
- ▶ All components must be suitable for the operating conditions when using an assembly.
- ▶ The operating instructions for the components, assemblies and the specific complete system must also always be observed.

**If the product can no longer be operated safely:**

1. Remove the product from operation and mark it accordingly.
  - ✓ It is then not permitted to continue using or operating the product.

**5.2 Assembly information**

The product must only be installed in the complete system with standard and compliant connection components (screw fittings, hoses, pipes, fixtures etc.).

The product must be shut down correctly prior to disassembly (in particular in combination with hydraulic accumulators).

**DANGER****Sudden movement of the hydraulic drives when disassembled incorrectly**

Risk of serious injury or death

- ▶ Depressurise the hydraulic system.
- ▶ Perform safety measures in preparation for maintenance.

### 5.2.1 General information

The variable displacement axial piston pump is suitable for use in an open circuit.

The pump can be mounted using a flange in accordance with specifications.

The housing pressure in the pump must always be greater than or equal to the ambient pressure.

**During assembly, note the following principles:**

- Only trained persons are allowed to mount or remove the pump.
- Always ensure absolute cleanliness to prevent contamination from affecting the pump.
- Remove all plastic plugs before operation.
- Avoid installation above the tank (see Chapter 5.2.3, "Installation positions").
- Observe the electric reference values.
- Before initial use, fill the pump with hydraulic fluid and bleed. Automatic pump filling via the suction line by opening the drain ports is not possible.
- Always supply the pump with hydraulic fluid from the start. Even just a short period with insufficient hydraulic fluid can damage the pump. Such damage is not immediately visible once the pump is put into operation.
- Never drain the pump.
- Hydraulic fluid which flows back into the tank must not be sucked back in immediately (install baffles!).
- If there is a check valve installed in the leakage line, negative pressure may occur in the pump housing during operation. If this happens, install an auxiliary pump to flush the housing.
- Before first use, run the pump for approx. 10 minutes at max. 50 bar after initial start-up.
- The leakage line must be installed in the tank in such a way that it ends below the oil level. The end of the leakage line should be positioned roughly equidistant from both the bottom of the tank and the oil level.
- Do not use the entire pressure range of the pump until it has been thoroughly bled and flushed.
- From the start, always keep the temperature within the specified range (see Chapter 3, "Parameters"). Never exceed the maximum temperature.
- Always comply with the cleanliness level of the hydraulic fluid. In addition, filter the hydraulic fluid appropriately (see Chapter 3, "Parameters").
- Self-installed filters in the suction line must be approved beforehand by HAWE Hydraulik.
- A system pressure-limiting valve must be installed in the pressure line so that the maximum system pressure is not exceeded.

## 5.2.2 Connections

The connecting lines' nominal width depends on:

- the given usage conditions
- viscosity of the hydraulic fluid
- start-up and operating temperature
- pump speed

HAWE recommends: Use hose lines (improved damping characteristics) instead of rigid pipelines.

<b>Pressure connection</b>	<ul style="list-style-type: none"> <li>▪ The pressure connection is established via SAE ports, <a href="#">see Chapter 4, "Dimensions"</a>. Metric mounting threads are used in deviation from the standard.</li> <li>▪ Observe the fitting manufacturers' specified tightening torques.</li> </ul>
<b>Suction port</b>	<ul style="list-style-type: none"> <li>▪ The suction port uses SAE ports, <a href="#">see Chapter 4, "Dimensions"</a>. Metric mounting threads are used in deviation from the standard.</li> <li>▪ If possible, route the suction line to the tank on a rising gradient. This allows trapped air to escape.</li> <li>▪ The absolute suction pressure must not fall below 0.85 bar.</li> <li>▪ A hose line should generally be used in preference to a rigid pipe line.</li> </ul>
<b>Drain port</b>	<ul style="list-style-type: none"> <li>▪ The pump features 3 drain ports, <a href="#">see Chapter 4, "Dimensions"</a>. The cross-section is determined by the max. permissible housing pressure.</li> <li>▪ Integrate the leakage line in the system in such a way as to prevent direct connection with the suction line of the pump.</li> <li>▪ All drain ports can be used simultaneously.</li> <li>▪ A separate leakage line from the controller to the tank is not required.</li> <li>▪ The top drain port can be used to fill the housing.</li> </ul>
<b>LS port X2</b>	<ul style="list-style-type: none"> <li>▪ The LS line is connected to the X2 port of the controller via an M12x1.5 threaded connection.</li> <li>▪ The nominal width of the line depends on the mounting position of the pump and should be 10 % of the pressure line capacity. A hose line should generally be used in preference to a rigid pipe connection.</li> <li>▪ When the proportional directional spool valve is in a neutral position, the LS line must always be fully relieved (only controller type LS0DA, LS0DE)! For controller type LS2DA, LS2DE relief occurs within the controller.</li> </ul>
<b>Pilot pressure port X5</b>	<p>The pilot pressure line is connected to the X5 port of the DF-DA controller via an M12x1.5 threaded connection.</p>

### 5.2.3 Installation positions

The variable displacement axial piston pump can be mounted in any installation position.

#### Horizontal installation

- ▶ For horizontal installation, use the uppermost drain port.



#### Vertical installation

Pump below the min. fill level

- ▶ Mount the pump so that the pump mounting flange is facing upwards.
- ▶ For vertical installation, use the uppermost drain port.
- ▶ Also connect the G 1/8" bleeding port to the pump flange (see Chapter 4, "Dimensions").
- ▶ Take appropriate measures to ensure continuous venting of this line (line routing/venting).

For installation with pump flange facing downwards: Get in touch with HAWE Hydraulik SE.

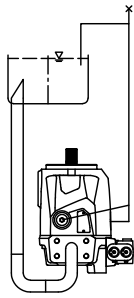

## 5.3 Operating instructions

Observe product configuration and pressure/flow rate.

The statements and technical parameters in this document must be strictly observed.

The instructions for the complete technical system must also always be followed.

### NOTICE

- ▶ Read the documentation carefully before usage.
- ▶ The documentation must be accessible to the operating and maintenance staff at all times.
- ▶ Keep documentation up to date after every addition or update.

### CAUTION

#### **Overloading components due to incorrect pressure settings.**

Risk of minor injury.

- Pay attention to the maximum operating pressure of the pump, valves and fittings.
- Always monitor the pressure gauge when setting and changing the pressure.

## Purity and filtering of the hydraulic fluid

Fine contamination can significantly impair the function of the product. Contamination can cause irreparable damage.

### Examples of fine contamination include:

- Swarf
- Rubber particles from hoses and seals
- Dirt due to assembly and maintenance
- Mechanical debris
- Chemical ageing of the hydraulic fluid

### NOTICE

#### **New hydraulic fluid from the manufacturer may not have the required purity.**

Damage to the product is possible.

- ▶ Filter new hydraulic fluid to a high quality when filling.
- ▶ Do not mix hydraulic fluids. Always use hydraulic fluid that is from the same manufacturer, of the same type, and with the same viscosity properties.

For smooth operation, pay attention to the cleanliness level of the hydraulic fluid (cleanliness level see Chapter 3, "Parameters").

Additionally applicable document: [D 5488/1](#) Oil recommendations

## 5.4 Maintenance information

This product is largely maintenance-free.

Check regularly (at least once a year) by visual inspection whether the hydraulic connections are damaged. If external leakages are found, shut down and repair the system.

Clean the surface of the device regularly (at least once a year) (dust deposits and dirt).

## 6 Other information

### 6.1 Planning information

#### Determination of nominal sizes

Delivery flow	$Q = \frac{V_g \cdot n \cdot \eta_v}{1000} (l/min)$	Q = Flow rate (lpm)
Drive torque	$M = \frac{V_g \cdot \Delta p}{20 \cdot \pi \cdot \eta_{mh}} (Nm)$	M = Torque (Nm)
Drive power	$P = \frac{2\pi \cdot M \cdot n}{60000} = \frac{Q \cdot \Delta p}{600 \cdot \eta_t} (kW)$	P = Power (kW)
		$V_g$ = Geom. output volume (cm <sup>3</sup> /rev.)
		$\Delta p$ = Differential pressure
		n = Speed (rpm)
		$\eta_v$ = Volumetric efficiency
		$\eta_{mh}$ = Mechanical-hydraulic efficiency
		$\eta_t$ = Overall efficiency ( $\eta_t = \eta_v \cdot \eta_{mh}$ )

## References

### Additional versions

- Variable displacement axial piston pump type V60N: D 7960 N
- Variable displacement axial piston pump type V30E: D 7960 E
- Variable displacement axial piston pump type V30D: D 7960
- Fixed displacement axial piston pump type K60N: D 7960 K
- Axial piston motors type M60N: D 7960 M
- Proportional directional spool valve type EDL: D 8086
- Proportional directional spool valves types PSL, PSV size 2: D 7700-2
- Proportional directional spool valves types PSL/PSV/PSM, size 3: D 7700-3
- Proportional directional spool valve, type PSL, PSM and PSV size 5: D 7700-5
- Proportional directional spool valve type PSLF, PSVF and SLF size 3: D 7700-3F
- Proportional directional spool valve type PSLF, PSVF and SLF size 5: D 7700-5F
- Proportional directional spool valve banks type PSLF and PSVF size 7: D 7700-7F
- Load-holding valve type CLHV: D 7918-VI-C
- Load-holding valve type CLHV: D 7918-VI-PIB
- Load-holding valve type LHDV: D 7770
- Proportional amplifier type EV1M3: D 7831/2
- Proportional amplifier type EV1D: D 7831 D
- Proportional amplifier type EV2S: D 7818/1

### observe operating instructions

- General operating manual for the assembly, initial operation and maintenance of hydraulic components and systems: B 5488

