



CE

Operating instructions
Capacitive sensors

UK

706413 / 00 07 / 2017

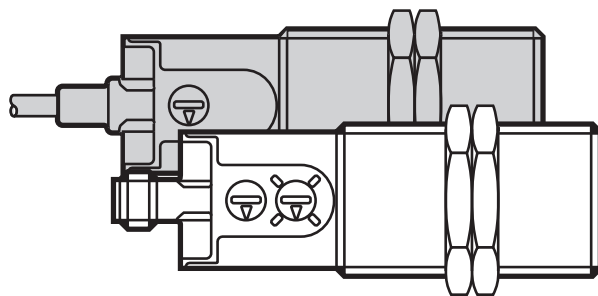

Contents

1 Preliminary note	3
1.1 Symbols used	3
2 Safety instructions	3
3 Functions and features	3
4 Installation.....	4
4.1 Notes on flush and non-flush installation	4
4.2 Notes on laying of the connection cable.....	5
5 Electrical connection.....	6
5.1 Wiring.....	6
6 Operating and display elements	6
7 Settings.....	7
7.1 Sensing range	7
7.2 NC/NO (optional)	7
7.3 Signal display (optional)	7
7.4 IO-Link	8
7.4.1 General information	8
7.4.2 Device-specific information.....	8
7.4.3 Parameter setting tools.....	8
8 Operation.....	8
9 Maintenance, repair and disposal.....	9

1 Preliminary note

1.1 Symbols used

- An instruction is indicated by "▶":
Example: ▶ Check whether the unit operates correctly.
- A reaction to the action is indicated by ">":
Example: > Yellow LED lights.



Important note

Non-compliance may result in malfunction or interference.

- LED on
- LED off

UK

2 Safety instructions

- Please read the operating instructions prior to set-up of the device. Ensure that the product is suitable for your application without any restrictions.
- The unit complies with the relevant regulations and EC directives.
- Improper or non-intended use may lead to malfunctions of the unit or to unwanted effects in your application.
- Installation, electrical connection, set-up, operation and maintenance of the unit must be carried out by qualified personnel authorised by the machine operator.

3 Functions and features

- Capacitive sensor for monitoring levels and positions.

4 Installation

► Mount the unit as shown:

- In contact with the medium

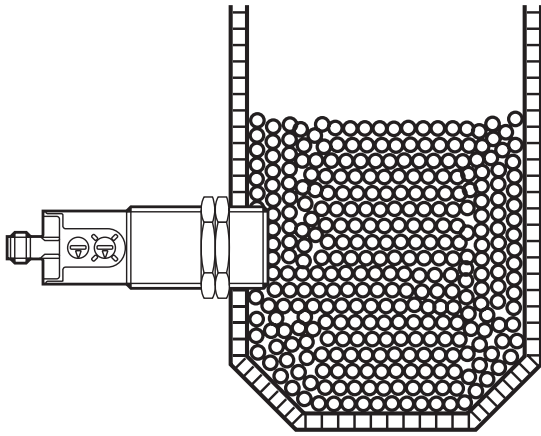

- Not in contact with the medium (only for non-metallic tanks)

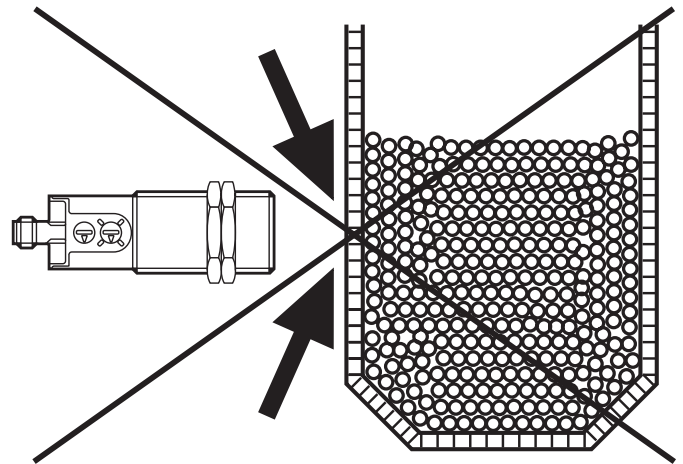
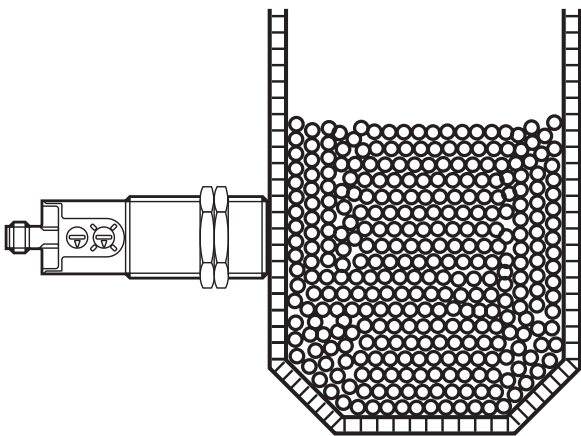

4.1 Notes on flush and non-flush installation



For flush installation of non-flush units the sensor properties change and the sensor can remain permanently switched (loss of function).

Free space around the sensing face

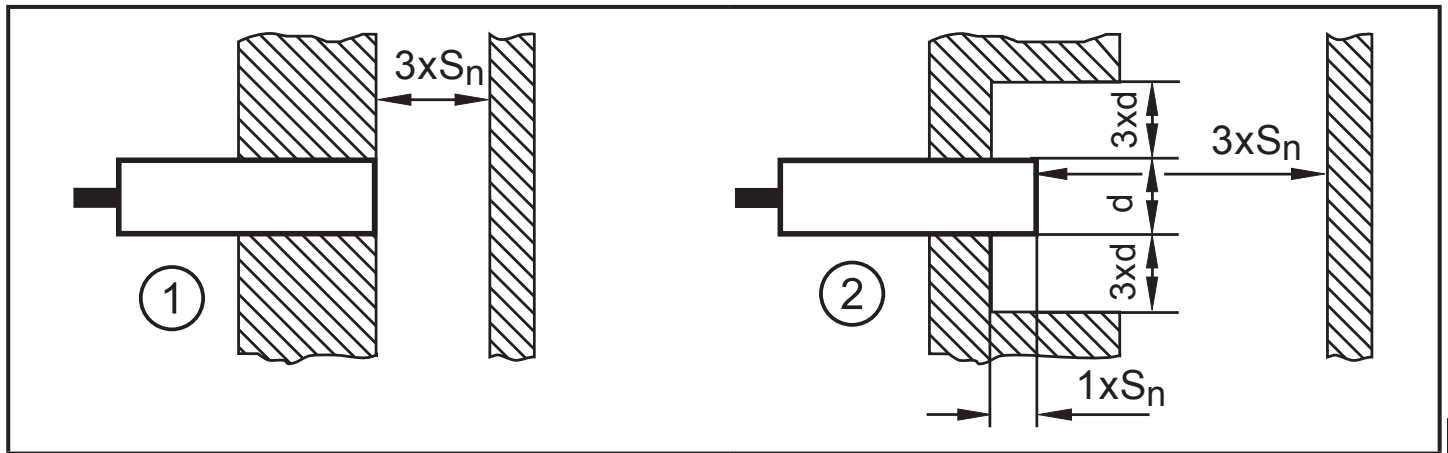

Minimum distances when mounting several switches of the same type

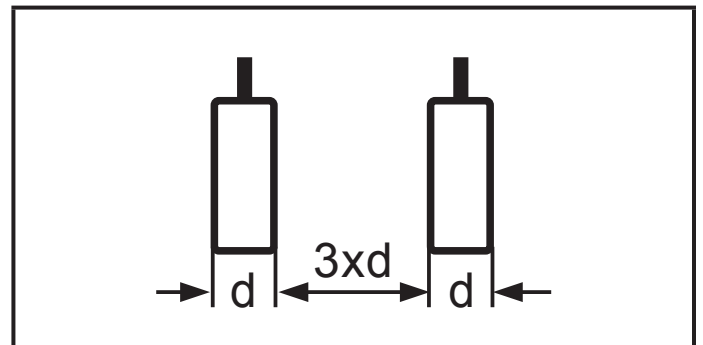
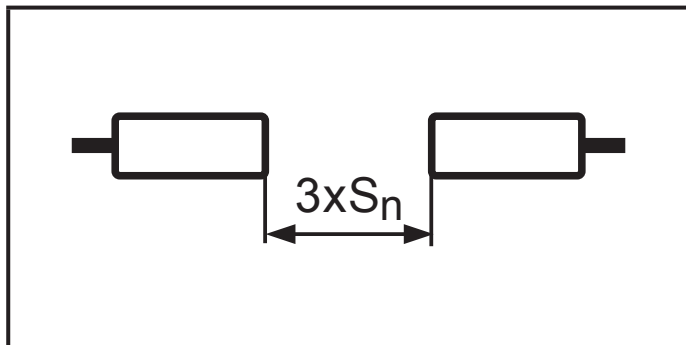

4.2 Notes on laying of the connection cable

- Lay cable as straight as possible and do not coil it.

UK

5 Electrical connection



The unit must be connected by a qualified electrician.

The national and international regulations for the installation of electrical equipment must be adhered to.

► Disconnect the installation from power and connect the unit.

5.1 Wiring

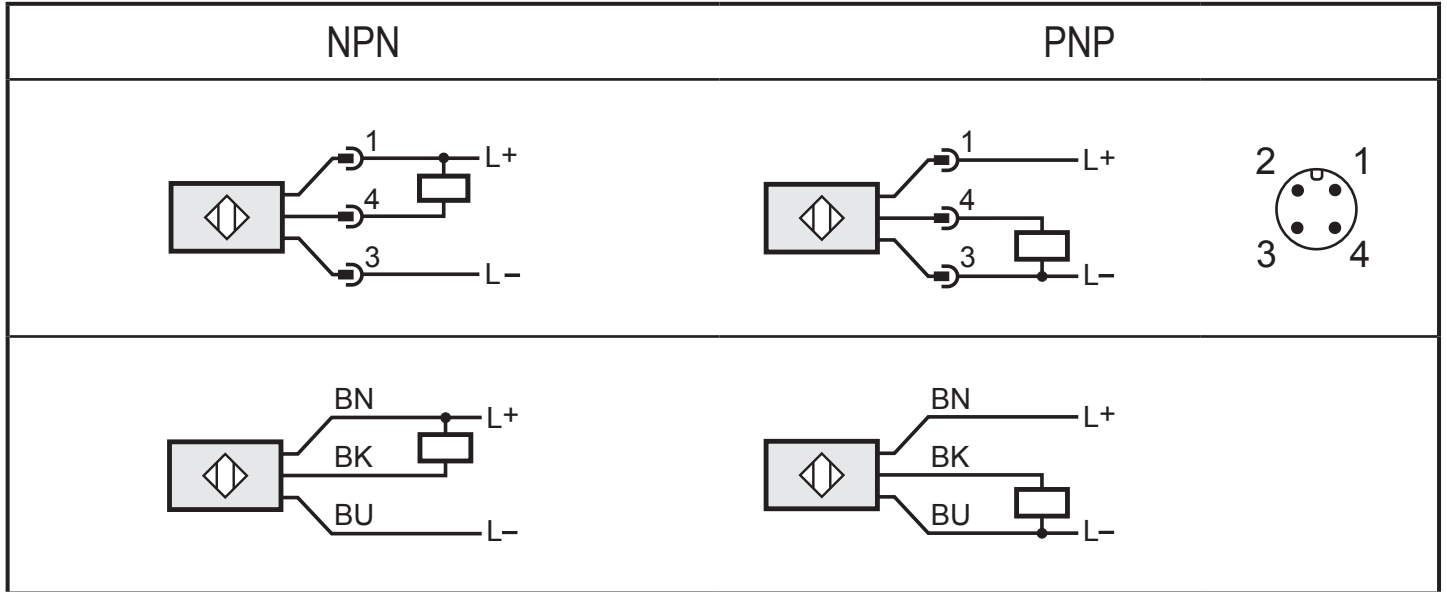

BN = brown, BK = black, BU = blue

PIN 4 / BK: OUT / IO-Link

6 Operating and display elements

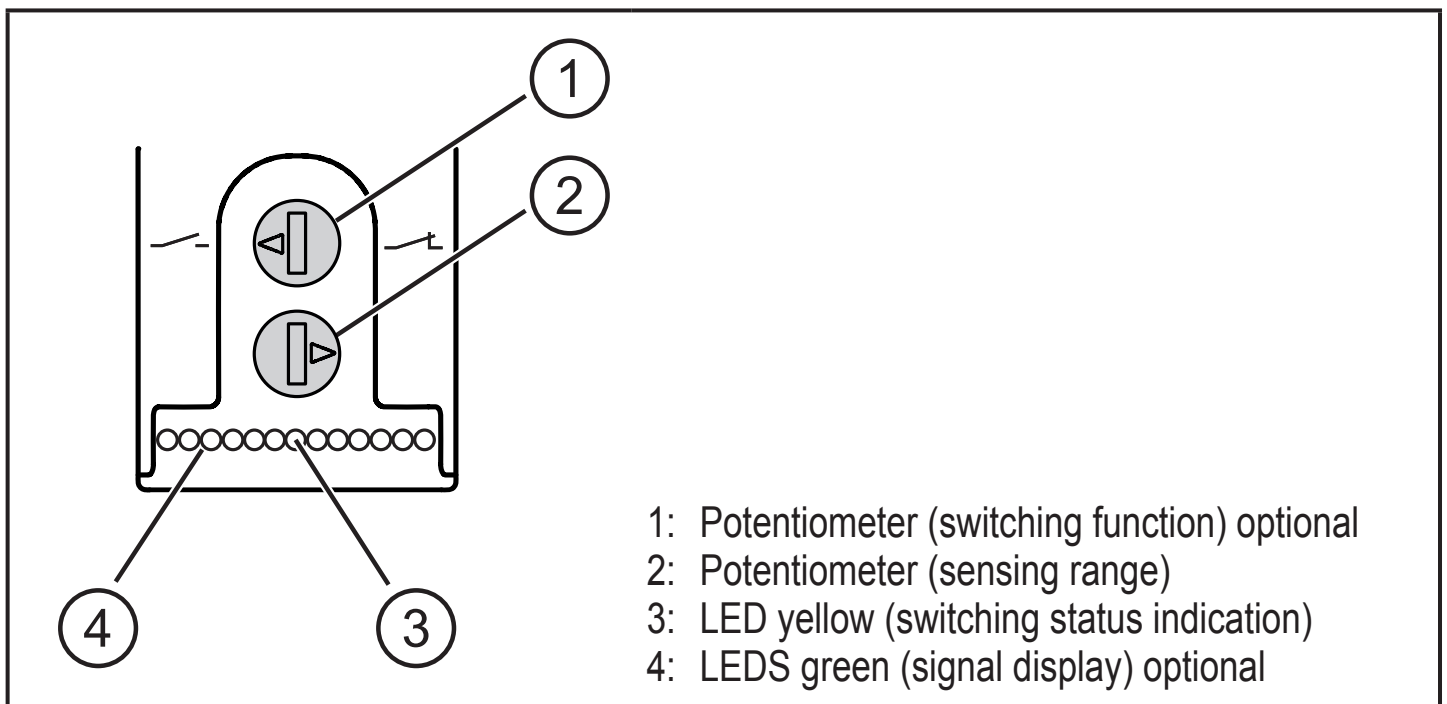

7 Settings

7.1 Sensing range

Set the sensing range by means of the potentiometer → 6 (2)

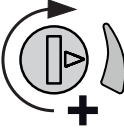
Increase the sensing range: 

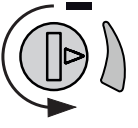
Reduce the sensing range: 

7.2 NC/NO (optional)

Set the required switching function by means of the potentiometer → 6 (1)

Normally closed:   

Normally open:   

7.3 Signal display (optional)

Yellow LED → 6 (3): Switching status indication (centre)
The green LEDs → 6 (4) indicate the distance to the switch point.

Optimum adjustment of the switch point:

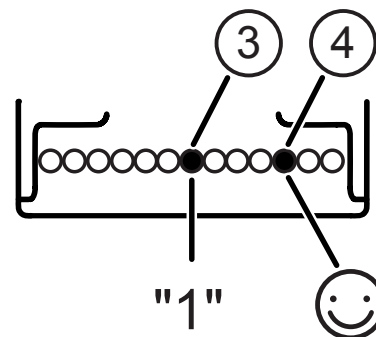
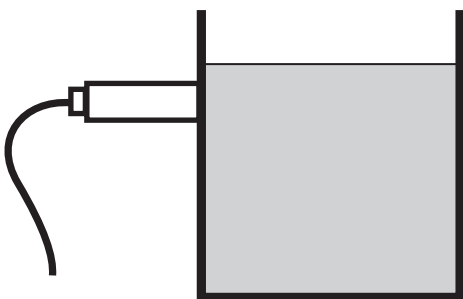
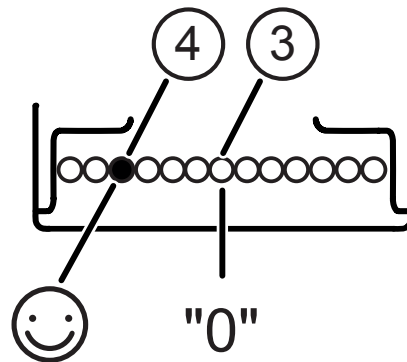
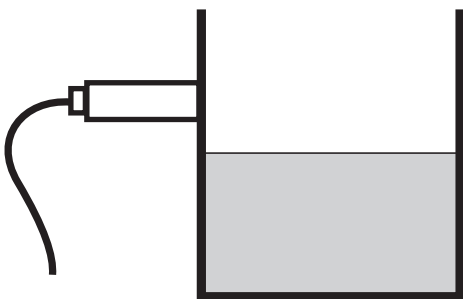

UK

7.4 IO-Link

7.4.1 General information

This unit has an IO-Link communication interface which requires an IO-Link-capable module (IO-Link master) for operation.

The IO-Link interface enables direct access to the sensor values and parameters and provides the possibility to set the parameters of the unit during operation. In addition communication is possible via a point-to-point connection with a USB adapter cable.

You will find more detailed information about IO-Link at www.ifm.com/uk/io-link.

7.4.2 Device-specific information

You will find the IODDs necessary for the configuration of the IO-Link device and detailed information about sensor values, diagnostic information and parameters in the overview table at www.ifm.com/uk/io-link.

7.4.3 Parameter setting tools

You will find all necessary information about the required IO-Link hardware and software (ifm LINERECORDER SENSOR) at www.ifm.com/uk/io-link.

8 Operation

Check whether the unit operates correctly. Bring about a sensor response by taking suitable measures.

Display by LEDs (independent of the programmed output configuration);

LED yellow OUT:	"0" switching output disabled
LED yellow ON:	"1" switching output enabled
LED green:	Readiness for operation (optional)

9 Maintenance, repair and disposal

The operation of the unit is maintenance-free. For a correct function ensure:

- Keep the sensing face and a clear space, if any, free from deposits and foreign bodies.

It is not possible to repair the unit.

After use dispose of the unit in an environmentally friendly way in accordance with the applicable national regulations.

Technical data and further information at www.ifm.com

UK