

External Gear Motors

RE 14 026/05.09Replaces:
RE 14 026/01.05**AZMF ..., AZMN ..., AZMG ...**

Model F = 8 ... 22.5 cm³/rev
 N = 25 und 28 cm³/rev
 G = 22.5 ... 45 cm³/rev

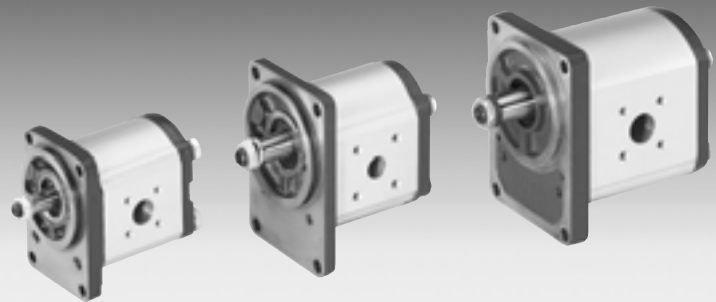

Contents

Function	2
Overview	3
Ordering code	4
Drive shaft	6
Front cover	7
Port connections	8
Motors with integral Valves and Sensors	9
Design calculations for Motors	10
Diagrams	10
Specifications	14
Drive arrangement	16
Connectors	17
Dimension Drawings	19
Notes	40

Page

General

Rexroth external gear motors are produced in 3 different models, with different displacements being produced by means of gears of differing widths.

Different versions of motors are achieved by the use of different flanges, shafts, valves and integrated speed sensors.

Features

- High pressures combined with small size and low weight
- Large speed ranges
- Broad viscosity and temperature ranges
- Reversible motors for 2- and 4-quadrant operation

Fields of application

- Road construction machines as road rollers and pavers
- Agricultural machines and forestry technology as harvesters and forestry machines
- Street vehicles such as busses, trucks and special vehicles and above all in hydrostatic fan drives.

Function

If pressurized oil is fed into the motor, a torque can be obtained from the shaft leading out of the housing. Here, a distinction is made between motors that rotate in one direction and reversible motors.

External gear motors that rotate in one direction

These are of asymmetrical design, i.e. the high and low pressure sides are defined and not interchangeable at will. In this case, reversible operation is not possible. In order to ensure a high efficiency level, a special running-in method is used for motors. Leakage oil is discharged internally to the outlet side. Pressure loading of the outlet is limited by the shaft seal.

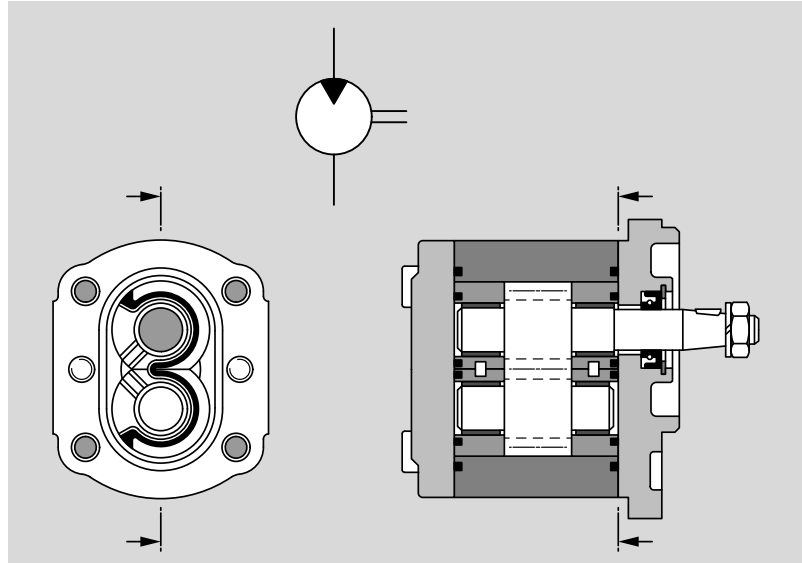

Reversible external gear motors

The displacement method in external gear motors is the reverse of the pump process. Reversible motors have a special feature, however. Their symmetrical construction means that the high or low pressure chambers are separate from the bearing and shaft seal chamber. The resulting leakage oil is routed through a separate oil drain gland in the housing cover. This oil drainage enables the motor to be subjected to load via the return line, which in turn allows the use of series connections. Due to the connection between the shaft seal and the low-pressure end, however, standard motors and pumps can only withstand a pressure of up to approx. 3 bar.

The figure shows a reversible gear motor for 4-quadrant operation, i.e. both output and input torque in both directions. (Hydraulic motor becomes a pump if load reversal occurs.)

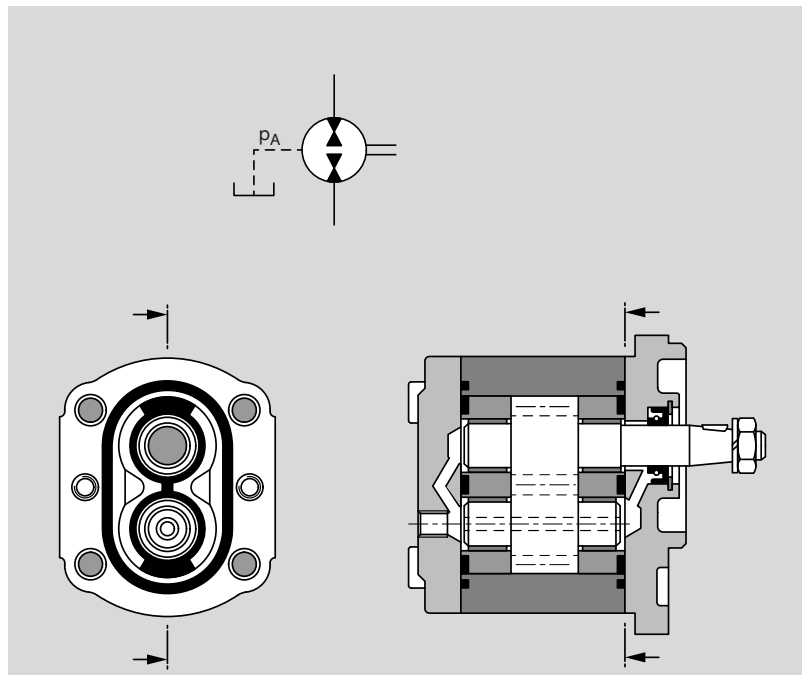

Product overview “Model F” preferential range

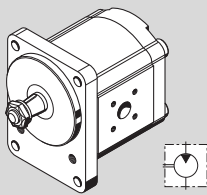
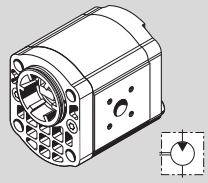
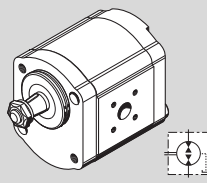
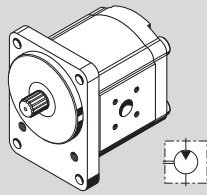
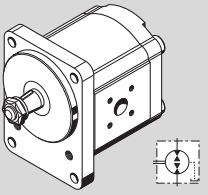
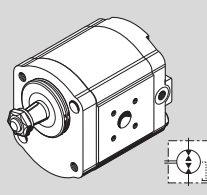
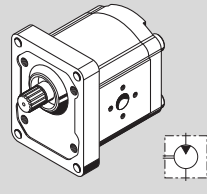
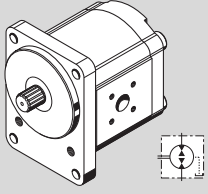
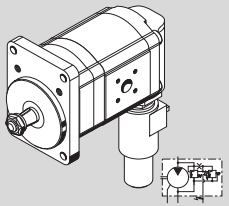
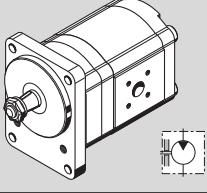
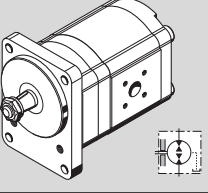
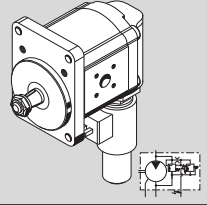
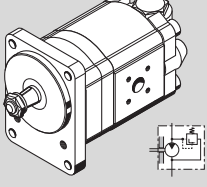
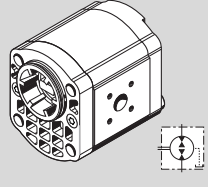
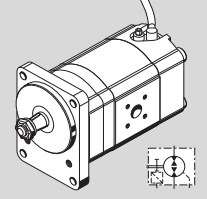
Version	Page	Version	Page	Version	Page
	19		24		29
	20		25		30
	21		26		31
	22		27		32
	23		28		34

Product overview “Model N” preferential range

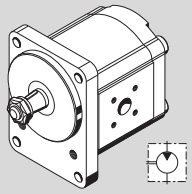
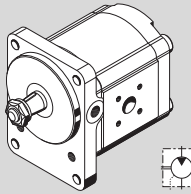
Version	Page	Version	Page
	35		36

Product overview “Model G” preferential range

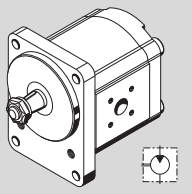
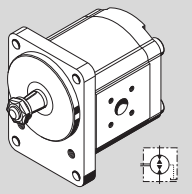
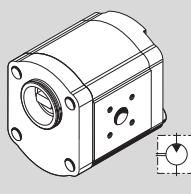
Version	Page	Version	Page	Version	Page
	37		38		39

Ordering code

External Gear Motors Model "F"













AZ	M	F	-	1x	-	022	R	C	B	20	M	B	200xx	-	S0001
-----------	----------	----------	---	-----------	---	------------	----------	----------	----------	-----------	----------	----------	--------------	---	--------------

Function	
M	= Motor
Series	
1x	= Standard bearing
Size (F)	
8.0 cm ³ /rev	= 008
11.0 cm ³ /rev	= 011
14.0 cm ³ /rev	= 014
16.0 cm ³ /rev	= 016
19.0 cm ³ /rev	= 019
22.5 cm ³ /rev	= 022
Direction of rotation	
Right	= R
Left	= L
Universal	= U

Special design*)



Valve adjustment	
PRV 200 bar	= 200 xx
PRV	= 180 xx
Rear cover	
Standard	= B
PRV	= G
drain oil line connection (axial)	= L
PRV excess flow internal	= D
Seals	
NBR	= M
FPM	= P
NBR, WDR in FPM	= K

*) The special equipments partly contained on the pages 20–35, are not considered in the representation of the ordering code.





Drive shafts	Front cover	Port connections
<p>C Tapered keyed shaft 1 : 5  B P suitable front cover</p>	<p>B Square flange Centring Ø 80 mm </p>	<p>20 Rectangular flange </p>
<p>N Tang drive  T</p>	<p>P 2-bolt mounting Centring Ø 50 mm </p>	<p>30 Rectangular flange </p>
<p>F Spline shaft DIN 5482 B 17 x 14  B P</p>	<p>O Square flange Centring Ø 36.47 mm </p>	
<p>S Tapered keyed shaft 1 : 5 for flange A  A</p>	<p>A Outboard bearing Ø 80 mm, Type 1 </p>	
	<p>N 2-bolt mounting Centring Ø 50 mm </p>	
	<p>T 4-bolt mounting Ø 52 mm, with O-ring </p>	

Ordering code

External Gear Motors Model "N"

AZ	M	N	-	1x	-	020	R	C	B	20	M	B		-	S0001																																																																																																																																																															
<table border="1"> <tr> <td>Function</td> <td></td> <td></td> <td></td> <td></td> <td></td> <td></td> <td></td> <td></td> <td></td> <td></td> <td></td> <td></td> <td></td> <td></td> <td></td> </tr> <tr> <td>M = Motor</td> <td></td> <td></td> <td></td> <td></td> <td></td> <td></td> <td></td> <td></td> <td></td> <td></td> <td></td> <td></td> <td></td> <td></td> <td></td> </tr> <tr> <td>Series</td> <td></td> <td></td> <td></td> <td></td> <td></td> <td></td> <td></td> <td></td> <td></td> <td></td> <td></td> <td></td> <td></td> <td></td> <td></td> </tr> <tr> <td>1x = Standard bearing</td> <td></td> <td></td> <td></td> <td></td> <td></td> <td></td> <td></td> <td></td> <td></td> <td></td> <td></td> <td></td> <td></td> <td></td> <td></td> </tr> <tr> <td>Size (N)</td> <td></td> <td></td> <td></td> <td></td> <td></td> <td></td> <td></td> <td></td> <td></td> <td></td> <td></td> <td></td> <td></td> <td></td> <td></td> </tr> <tr> <td>25.0 cm³/rev = 025</td> <td></td> <td></td> <td></td> <td></td> <td></td> <td></td> <td></td> <td></td> <td></td> <td></td> <td></td> <td></td> <td></td> <td></td> <td></td> </tr> <tr> <td>28.0 cm³/rev = 028</td> <td></td> <td></td> <td></td> <td></td> <td></td> <td></td> <td></td> <td></td> <td></td> <td></td> <td></td> <td></td> <td></td> <td></td> <td></td> </tr> <tr> <td>Direction of rotation</td> <td></td> <td></td> <td></td> <td></td> <td></td> <td></td> <td></td> <td></td> <td></td> <td></td> <td></td> <td></td> <td></td> <td></td> <td></td> </tr> <tr> <td>Right = R</td> <td></td> <td></td> <td></td> <td></td> <td></td> <td></td> <td></td> <td></td> <td></td> <td></td> <td></td> <td></td> <td></td> <td></td> <td></td> </tr> <tr> <td>Left = L</td> <td></td> <td></td> <td></td> <td></td> <td></td> <td></td> <td></td> <td></td> <td></td> <td></td> <td></td> <td></td> <td></td> <td></td> <td></td> </tr> </table>															Function																M = Motor																Series																1x = Standard bearing																Size (N)																25.0 cm ³ /rev = 025																28.0 cm ³ /rev = 028																Direction of rotation																Right = R																Left = L															
Function																																																																																																																																																																														
M = Motor																																																																																																																																																																														
Series																																																																																																																																																																														
1x = Standard bearing																																																																																																																																																																														
Size (N)																																																																																																																																																																														
25.0 cm ³ /rev = 025																																																																																																																																																																														
28.0 cm ³ /rev = 028																																																																																																																																																																														
Direction of rotation																																																																																																																																																																														
Right = R																																																																																																																																																																														
Left = L																																																																																																																																																																														
<table border="1"> <tr> <td>Special design</td> <td></td> <td></td> <td></td> <td></td> <td></td> <td></td> <td></td> <td></td> <td></td> <td></td> <td></td> <td></td> <td></td> <td></td> <td></td> </tr> <tr> <td>Rear cover</td> <td></td> <td></td> <td></td> <td></td> <td></td> <td></td> <td></td> <td></td> <td></td> <td></td> <td></td> <td></td> <td></td> <td></td> <td></td> </tr> <tr> <td>Standard = B</td> <td></td> <td></td> <td></td> <td></td> <td></td> <td></td> <td></td> <td></td> <td></td> <td></td> <td></td> <td></td> <td></td> <td></td> <td></td> </tr> <tr> <td>Special design = X</td> <td></td> <td></td> <td></td> <td></td> <td></td> <td></td> <td></td> <td></td> <td></td> <td></td> <td></td> <td></td> <td></td> <td></td> <td></td> </tr> <tr> <td>Seals</td> <td></td> <td></td> <td></td> <td></td> <td></td> <td></td> <td></td> <td></td> <td></td> <td></td> <td></td> <td></td> <td></td> <td></td> <td></td> </tr> <tr> <td>NBR = M</td> <td></td> <td></td> <td></td> <td></td> <td></td> <td></td> <td></td> <td></td> <td></td> <td></td> <td></td> <td></td> <td></td> <td></td> <td></td> </tr> <tr> <td>FPM = P</td> <td></td> <td></td> <td></td> <td></td> <td></td> <td></td> <td></td> <td></td> <td></td> <td></td> <td></td> <td></td> <td></td> <td></td> <td></td> </tr> </table>															Special design																Rear cover																Standard = B																Special design = X																Seals																NBR = M																FPM = P																																																															
Special design																																																																																																																																																																														
Rear cover																																																																																																																																																																														
Standard = B																																																																																																																																																																														
Special design = X																																																																																																																																																																														
Seals																																																																																																																																																																														
NBR = M																																																																																																																																																																														
FPM = P																																																																																																																																																																														
Drive shafts					Front cover					Port connections																																																																																																																																																																				
C	Tapered keyed shaft 1 : 5				B	Suitable front cover				B	Square flange Centring Ø 100 mm		20	Rectangular flange																																																																																																																																																																

External Gear Motors Model "G"

AZ	M	G	-	1x	-	022	R	C	B	20	M	B		-	S0001																																																																																																																																																																																																															
<table border="1"> <tr> <td>Function</td> <td></td> <td></td> <td></td> <td></td> <td></td> <td></td> <td></td> <td></td> <td></td> <td></td> <td></td> <td></td> <td></td> <td></td> <td></td> </tr> <tr> <td>M = Motor</td> <td></td> <td></td> <td></td> <td></td> <td></td> <td></td> <td></td> <td></td> <td></td> <td></td> <td></td> <td></td> <td></td> <td></td> <td></td> </tr> <tr> <td>Model</td> <td></td> <td></td> <td></td> <td></td> <td></td> <td></td> <td></td> <td></td> <td></td> <td></td> <td></td> <td></td> <td></td> <td></td> <td></td> </tr> <tr> <td>G = 22.5...56 cm³/rev</td> <td></td> <td></td> <td></td> <td></td> <td></td> <td></td> <td></td> <td></td> <td></td> <td></td> <td></td> <td></td> <td></td> <td></td> <td></td> </tr> <tr> <td>Size (G)</td> <td></td> <td></td> <td></td> <td></td> <td></td> <td></td> <td></td> <td></td> <td></td> <td></td> <td></td> <td></td> <td></td> <td></td> <td></td> </tr> <tr> <td>22.5 cm³/rev = 022</td> <td></td> <td></td> <td></td> <td></td> <td></td> <td></td> <td></td> <td></td> <td></td> <td></td> <td></td> <td></td> <td></td> <td></td> <td></td> </tr> <tr> <td>28.0 cm³/rev = 028</td> <td></td> <td></td> <td></td> <td></td> <td></td> <td></td> <td></td> <td></td> <td></td> <td></td> <td></td> <td></td> <td></td> <td></td> <td></td> </tr> <tr> <td>32.0 cm³/rev = 032</td> <td></td> <td></td> <td></td> <td></td> <td></td> <td></td> <td></td> <td></td> <td></td> <td></td> <td></td> <td></td> <td></td> <td></td> <td></td> </tr> <tr> <td>45.0 cm³/rev = 045</td> <td></td> <td></td> <td></td> <td></td> <td></td> <td></td> <td></td> <td></td> <td></td> <td></td> <td></td> <td></td> <td></td> <td></td> <td></td> </tr> <tr> <td>Direction of rotation</td> <td></td> <td></td> <td></td> <td></td> <td></td> <td></td> <td></td> <td></td> <td></td> <td></td> <td></td> <td></td> <td></td> <td></td> <td></td> </tr> <tr> <td>Right = R</td> <td></td> <td></td> <td></td> <td></td> <td></td> <td></td> <td></td> <td></td> <td></td> <td></td> <td></td> <td></td> <td></td> <td></td> <td></td> </tr> <tr> <td>Left = L</td> <td></td> <td></td> <td></td> <td></td> <td></td> <td></td> <td></td> <td></td> <td></td> <td></td> <td></td> <td></td> <td></td> <td></td> <td></td> </tr> <tr> <td>Universal = U</td> <td></td> <td></td> <td></td> <td></td> <td></td> <td></td> <td></td> <td></td> <td></td> <td></td> <td></td> <td></td> <td></td> <td></td> <td></td> </tr> </table>															Function																M = Motor																Model																G = 22.5...56 cm³/rev																Size (G)																22.5 cm ³ /rev = 022																28.0 cm ³ /rev = 028																32.0 cm ³ /rev = 032																45.0 cm ³ /rev = 045																Direction of rotation																Right = R																Left = L																Universal = U															
Function																																																																																																																																																																																																																														
M = Motor																																																																																																																																																																																																																														
Model																																																																																																																																																																																																																														
G = 22.5...56 cm³/rev																																																																																																																																																																																																																														
Size (G)																																																																																																																																																																																																																														
22.5 cm ³ /rev = 022																																																																																																																																																																																																																														
28.0 cm ³ /rev = 028																																																																																																																																																																																																																														
32.0 cm ³ /rev = 032																																																																																																																																																																																																																														
45.0 cm ³ /rev = 045																																																																																																																																																																																																																														
Direction of rotation																																																																																																																																																																																																																														
Right = R																																																																																																																																																																																																																														
Left = L																																																																																																																																																																																																																														
Universal = U																																																																																																																																																																																																																														
<table border="1"> <tr> <td>Special design</td> <td></td> <td></td> <td></td> <td></td> <td></td> <td></td> <td></td> <td></td> <td></td> <td></td> <td></td> <td></td> <td></td> <td></td> <td></td> </tr> <tr> <td>Rear cover</td> <td></td> <td></td> <td></td> <td></td> <td></td> <td></td> <td></td> <td></td> <td></td> <td></td> <td></td> <td></td> <td></td> <td></td> <td></td> </tr> <tr> <td>Standard = B</td> <td></td> <td></td> <td></td> <td></td> <td></td> <td></td> <td></td> <td></td> <td></td> <td></td> <td></td> <td></td> <td></td> <td></td> <td></td> </tr> <tr> <td>Special design = X</td> <td></td> <td></td> <td></td> <td></td> <td></td> <td></td> <td></td> <td></td> <td></td> <td></td> <td></td> <td></td> <td></td> <td></td> <td></td> </tr> <tr> <td>Seals</td> <td></td> <td></td> <td></td> <td></td> <td></td> <td></td> <td></td> <td></td> <td></td> <td></td> <td></td> <td></td> <td></td> <td></td> <td></td> </tr> <tr> <td>NBR = M</td> <td></td> <td></td> <td></td> <td></td> <td></td> <td></td> <td></td> <td></td> <td></td> <td></td> <td></td> <td></td> <td></td> <td></td> <td></td> </tr> <tr> <td>NBR, WDR in FPM = K</td> <td></td> <td></td> <td></td> <td></td> <td></td> <td></td> <td></td> <td></td> <td></td> <td></td> <td></td> <td></td> <td></td> <td></td> <td></td> </tr> </table>															Special design																Rear cover																Standard = B																Special design = X																Seals																NBR = M																NBR, WDR in FPM = K																																																																																																															
Special design																																																																																																																																																																																																																														
Rear cover																																																																																																																																																																																																																														
Standard = B																																																																																																																																																																																																																														
Special design = X																																																																																																																																																																																																																														
Seals																																																																																																																																																																																																																														
NBR = M																																																																																																																																																																																																																														
NBR, WDR in FPM = K																																																																																																																																																																																																																														
Drive shafts					Front cover					Port connections																																																																																																																																																																																																																				
C	Tapered keyed shaft 1 : 5				B	Suitable front cover				B	Square flange Centring Ø 105 mm		20	Rectangular flange																																																																																																																																																																																																																
N	Tang drive				M					M	2-bolt mounting Ø 52 mm, with O-ring																																																																																																																																																																																																																			

Drive shaft model "F"

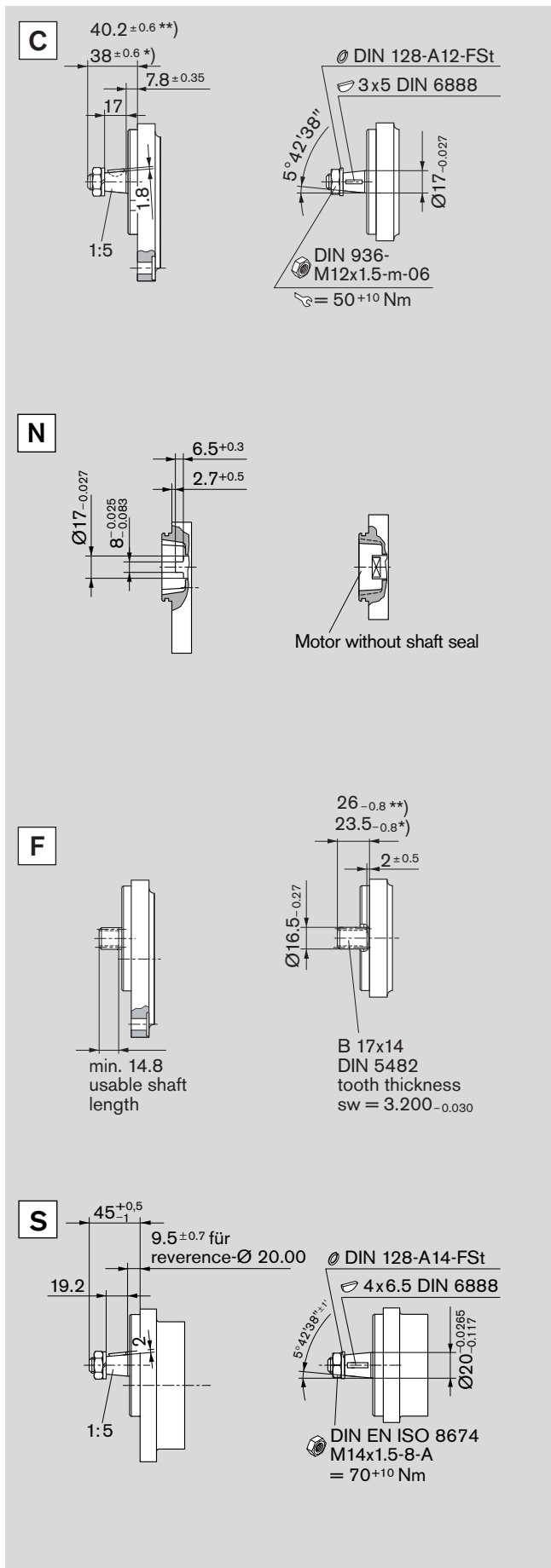

Drive shaft model "N"

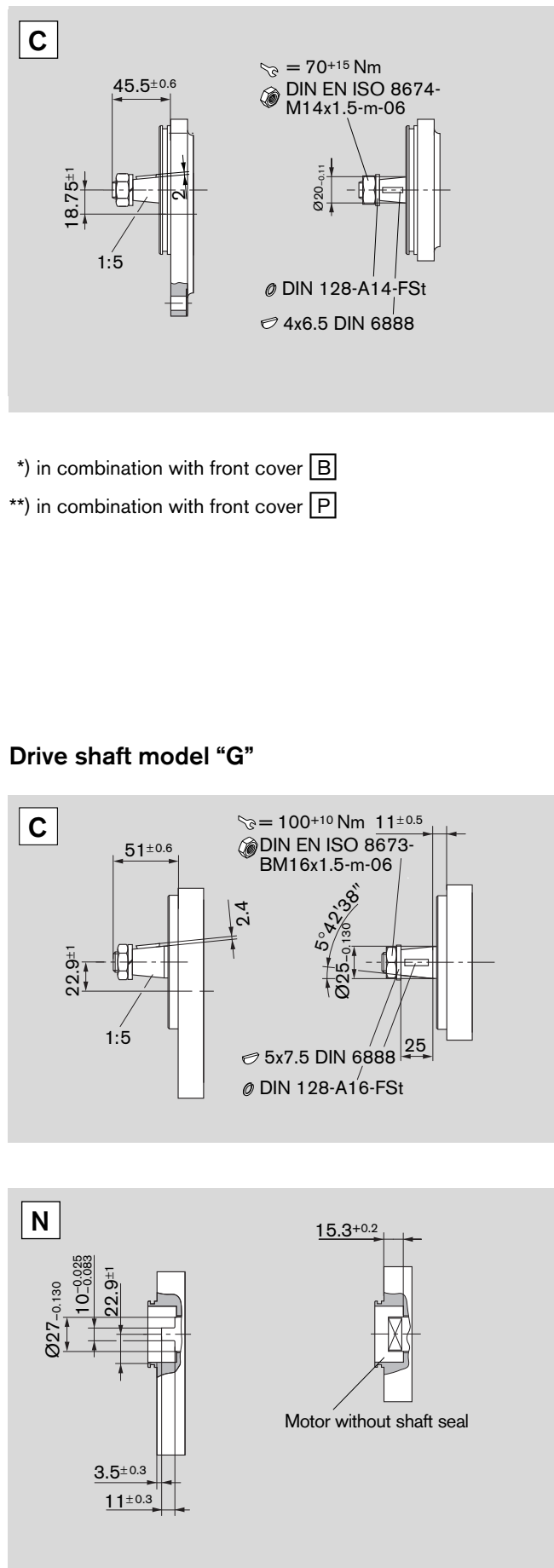

*) in combination with front cover **B**

***) in combination with front cover **P**

Drive shaft model "G"

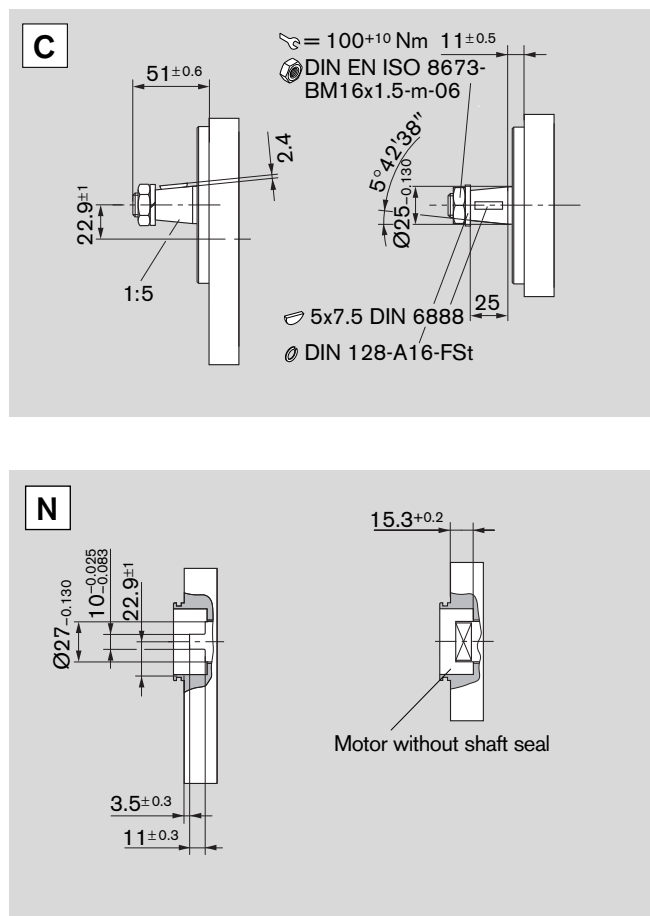

Front cover model "F"

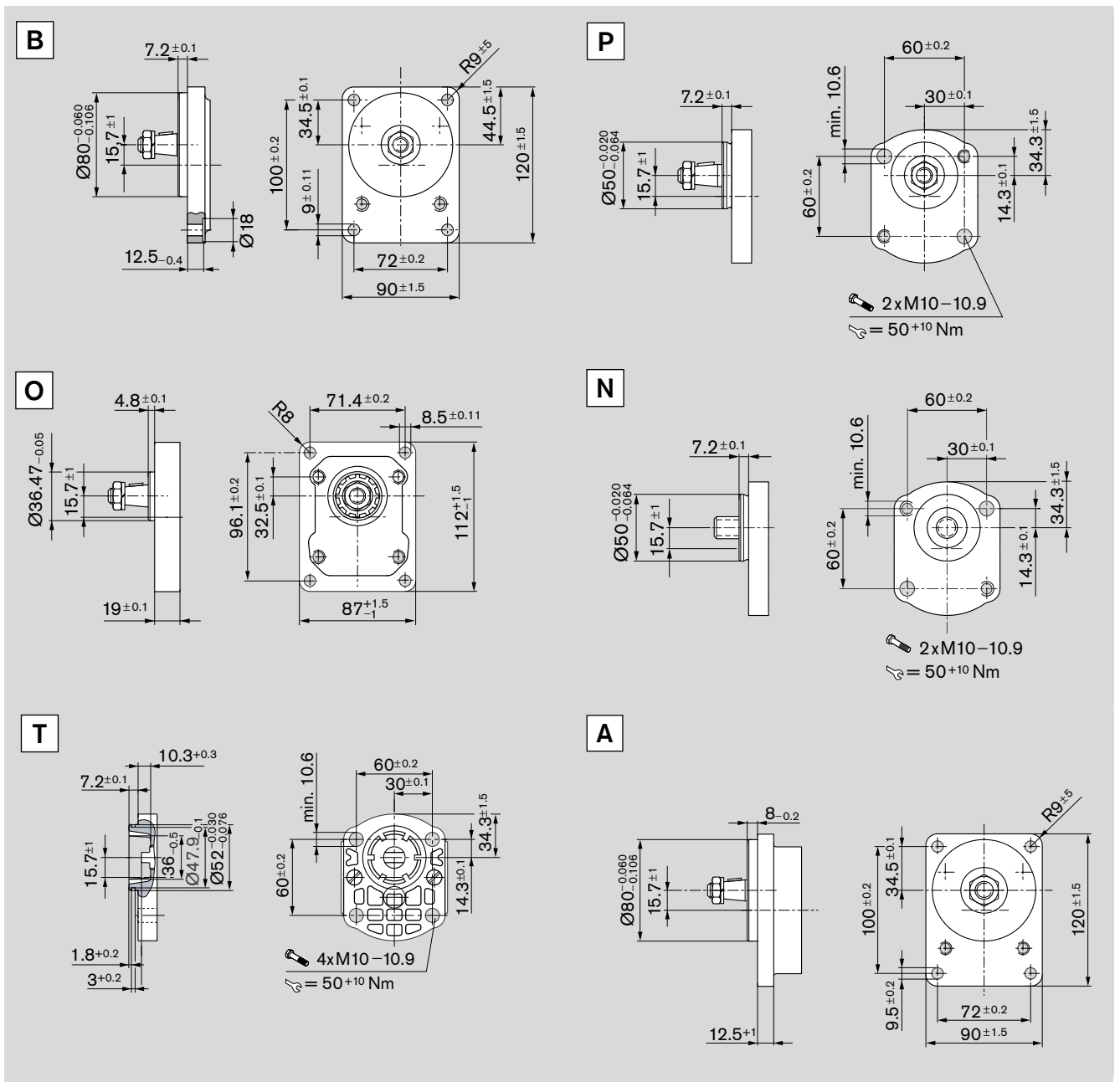

Front cover model "N"

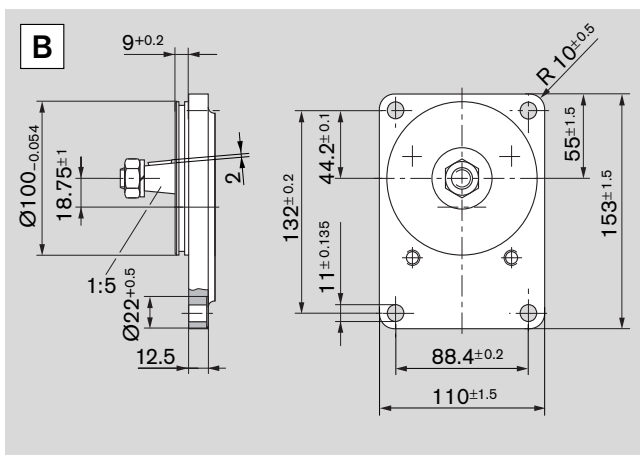

Front cover model "G"

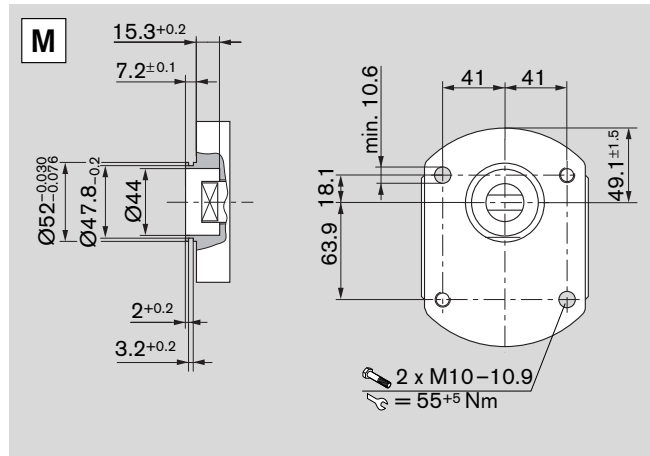
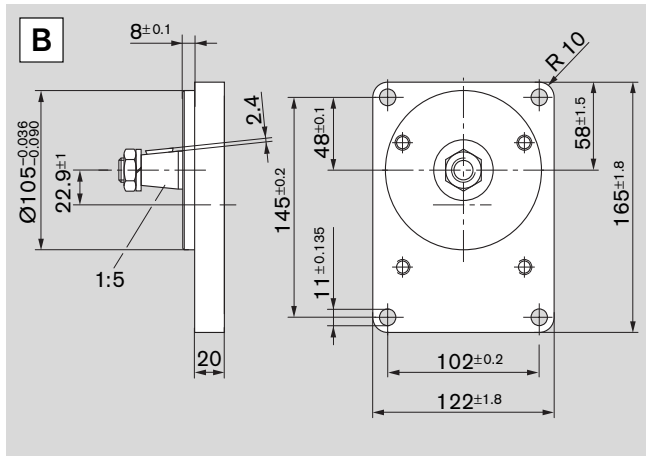

Port connections

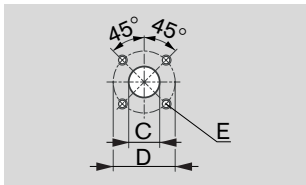

20 Rectangular flange

Synopsis of Type	Size	Inlet side			Outlet side		
		C	D	E	C	D	E
	8.0 ... 22.5 cm ³	15	35	M6 utilizable depth 13	20	40	M6 utilizable depth 13
	22.5 ... 45.0 cm ³	18	55	M8 utilizable depth 13	26	55	M8 utilizable depth 13

Synopsis of Type	Size	Port connections (direction of rotation universal)		
		C	D	E
	8.0 ... 22.5 cm ³	15	35	M6 utilizable depth 13
	22.5 ... 45.0 cm ³	18	55	M8 utilizable depth 13

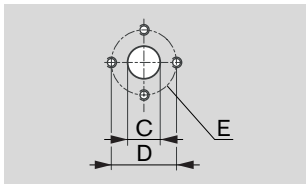

30 Rectangular flange

Synopsis of Type	Size	Inlet side				Outlet side		
		C	D	E	C	D	E	
	4 ... 8 cm ³	13.5	30.2	M6 utilizable depth 13	13.5	30.2	M6 utilizable depth 13	
	11 ... 28 cm ³				20.0	39.7	M8 utilizable depth 13	

External gear motors with integrated valves, sensors



Pages 31, 32

Gear motor with integrated, pilot-operated proportional pressure relief valve and rotary shaft seal relieved of load thanks to the three-chamber design.

The use of gear motors without this relief of the rotary shaft seal is not recommended due to the loads from the oil return line, particularly when the oil is cold. The basis of this drive unit is a motor model "F". The pilot proportional pressure relief valve is integrated in the rear end cover. This unit has the following advantages:

- No pipework necessary for the functioning of the prop. pressure relief valve
- Integrated pressure relief
- Fail-safe function in the event of power loss
- Drag speed virtually zero
- Motor speed prop. controllable
- Unaffected by pressure loads from the outlet

Additional information see:

Hydrostatic fan drives 1 987 761 700

<http://www.boschrexroth.com/brm>

External gear motors with pressure relief valve



Page 23

return port pressure < 3 bar (10 bar at starting)

External gear motors with integrated speed sensor



Page 34

The DSM1-10 Hall-effect speed sensor was specially developed for tough use in mobile work machines. The sensor detects the speed signal of ferromagnetic gear wheels. In this process, as an active sensor, it supplies a signal with constant amplitude independent of the rotational speed.

Due to its compact, sturdy design, the gear motor with integrated sensor is suitable for the applications such as

- In fan drives for buses, trucks and construction machinery from 7 to 20 kW
- As a vibration drive for road rollers and road construction machinery

For additional information see: **Speed Sensor DSM RE 95 132**

<http://www.boschrexroth.com/brm>

Design calculations for motors

The design calculations for motors are based on the following parameters:

V [cm ³ /rev]	Displacement
Q [l/min]	Inlet flow rate
p [bar]	Pressure (p_1, p_A)
M [Nm]	Output torque
n [rev/min]	Output speed
P [kW]	Output power

It is also necessary to allow for different efficiencies such as:

η_v	Volumetric efficiency
η_{hm}	Mechanical-hydraulic efficiency
η_t	Total efficiency

The following formulas describe the various relationships. They include correction factors for adapting the parameters to the usual units encountered in practice.

Note: Diagrams providing approximate selection data can be found on subsequent pages. These graphs contain the levels of efficiency in each case.

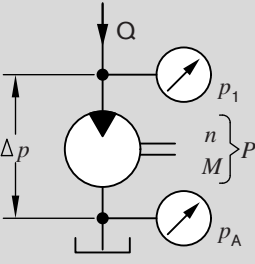

$$Q = \frac{V \cdot n}{\eta_v} \cdot 10^{-1}$$

$$\Delta p = \frac{M}{1.59 \cdot V \cdot \eta_{hm}} \cdot 10^4$$

$$P = \frac{Q \cdot \Delta p \cdot \eta_t}{6} \cdot 10^{-4}$$

$$V = \frac{Q \cdot \eta_v}{n} \cdot 10$$

$$V = 1.59 \cdot \frac{M}{\Delta p \cdot \eta_{hm}} \cdot 10^4$$

$$n = \frac{Q \cdot \eta_v}{V} \cdot 10$$

$$M = 1.59 \cdot V \cdot \Delta p \cdot \eta_{hm} \cdot 10^{-4}$$

	[%]			Note: η [%]
Q	— η_v —>	V [cm ³ /rev]	Q [l/min]	Δp [bar]
Δp	— η_{hm} —>	n [rev/min]	P [kW]	M [Nm]
$\Delta p \cdot Q$	— η_t —>			

Diagrams Model "F"

$v = 35 \text{ mm}^2/\text{s}, T = 50 \text{ }^\circ\text{C}$

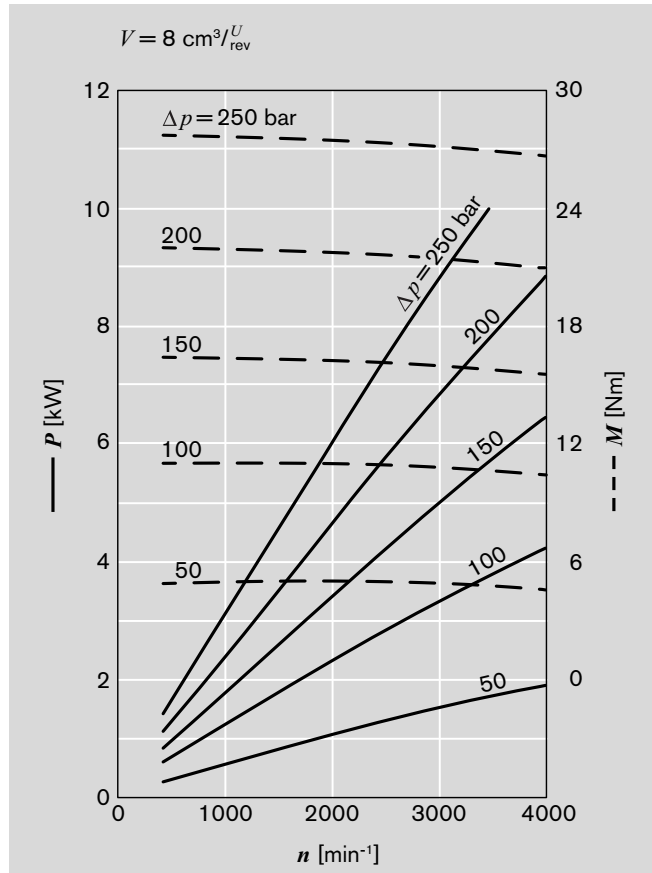
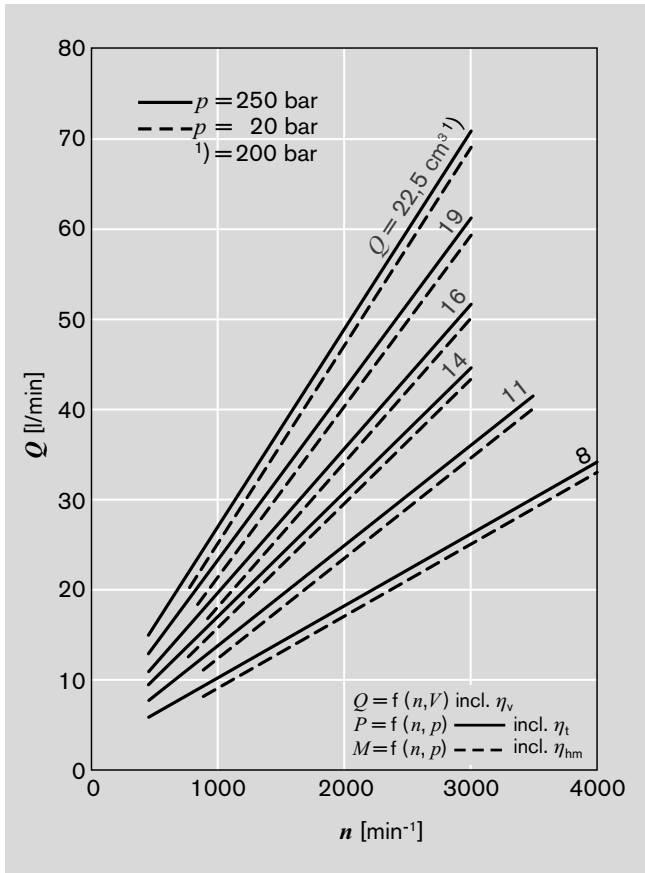

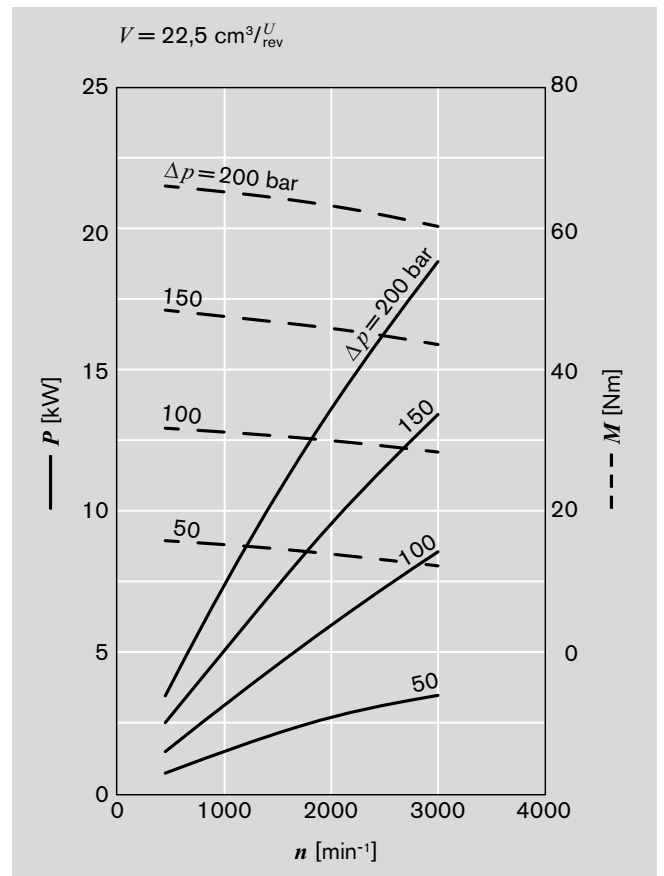
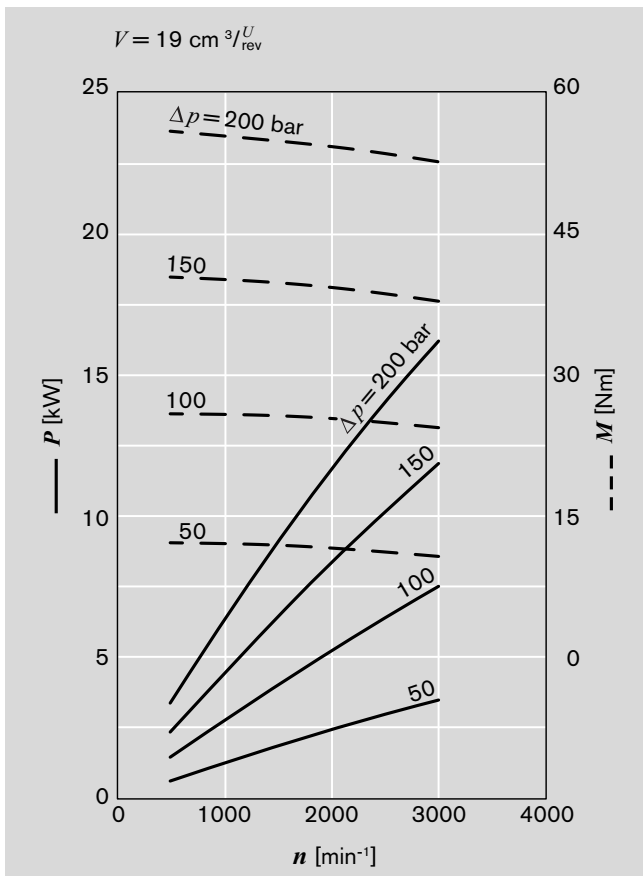
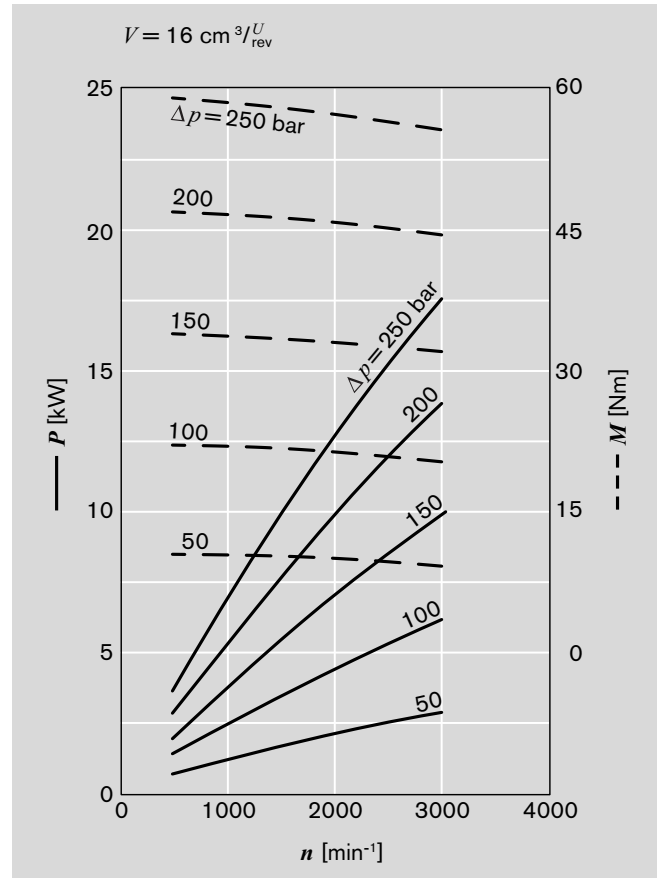
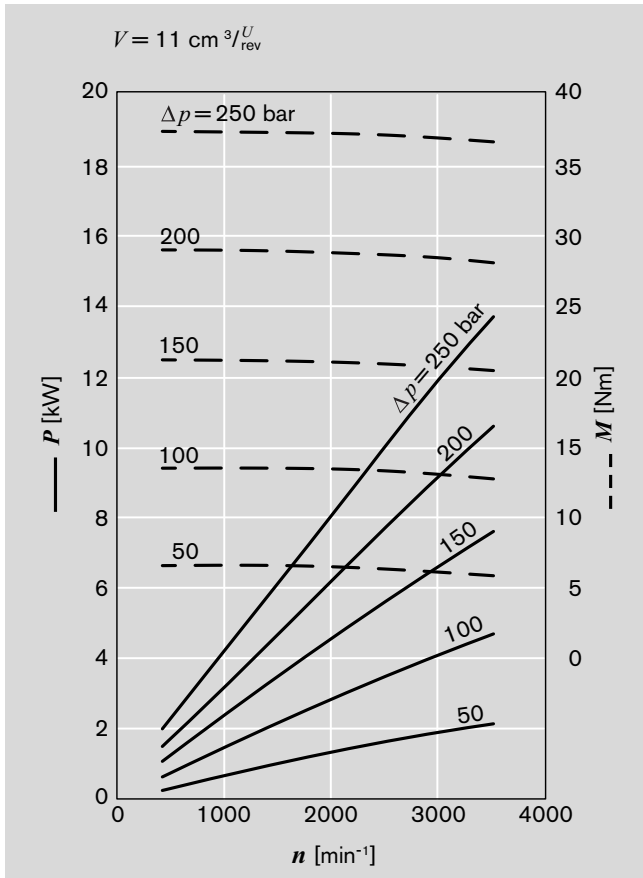

Diagrams Model "N"

$\nu = 35 \text{ mm}^2/\text{s}, T = 50 \text{ }^\circ\text{C}$

$Q = f(n, V)$ incl. η_v
 $P = f(n, p)$ ——— incl. η_t
 $M = f(n, p)$ - - - incl. η_{hm}

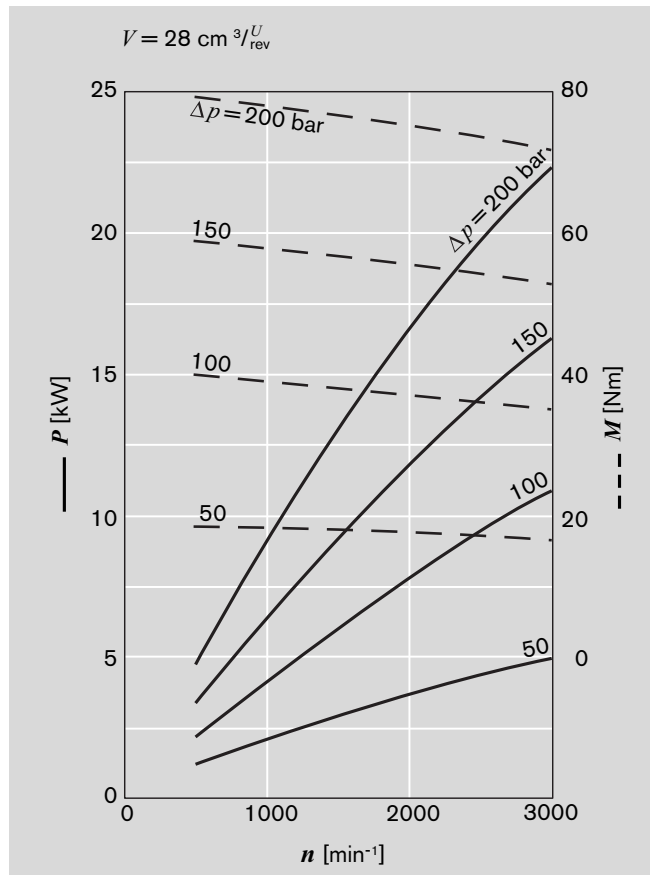
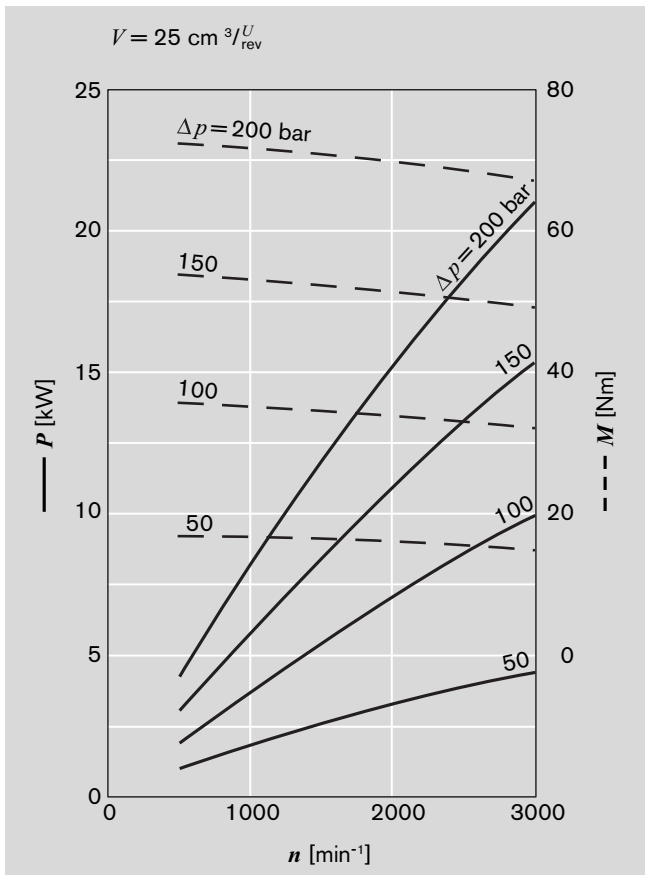
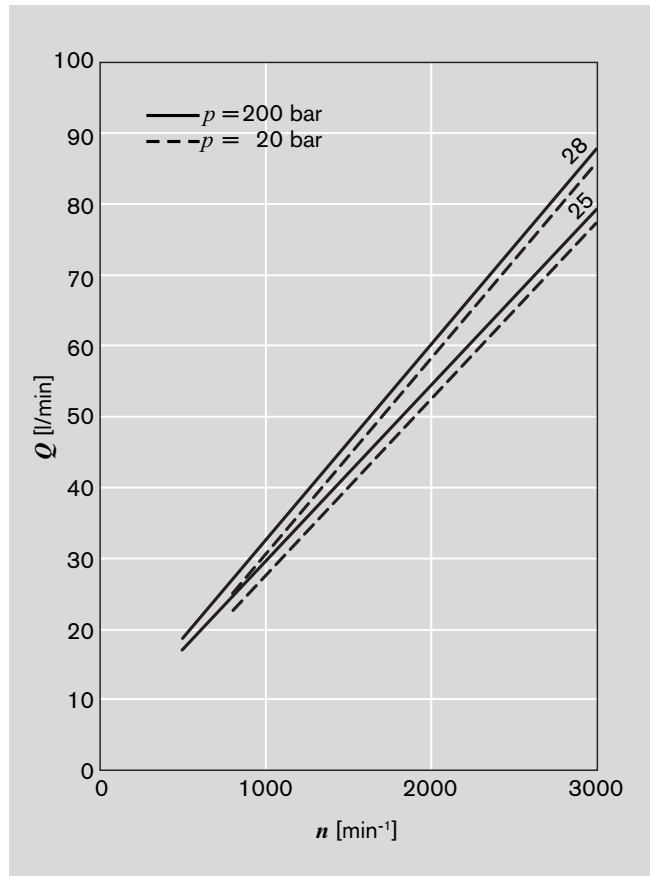

Diagrams Model "G"

$v = 35 \text{ mm}^2/\text{s}, T = 50 \text{ }^\circ\text{C}$

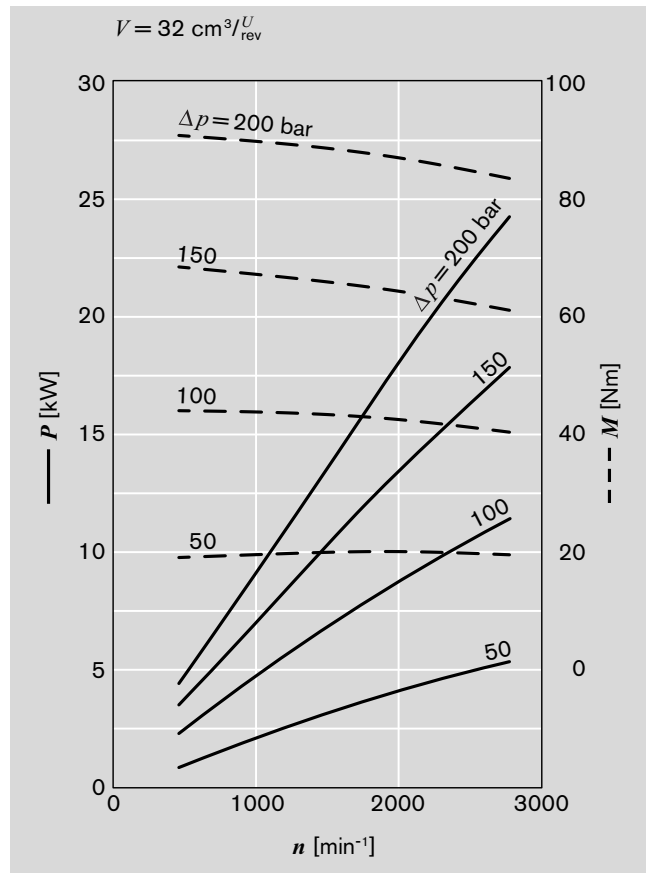
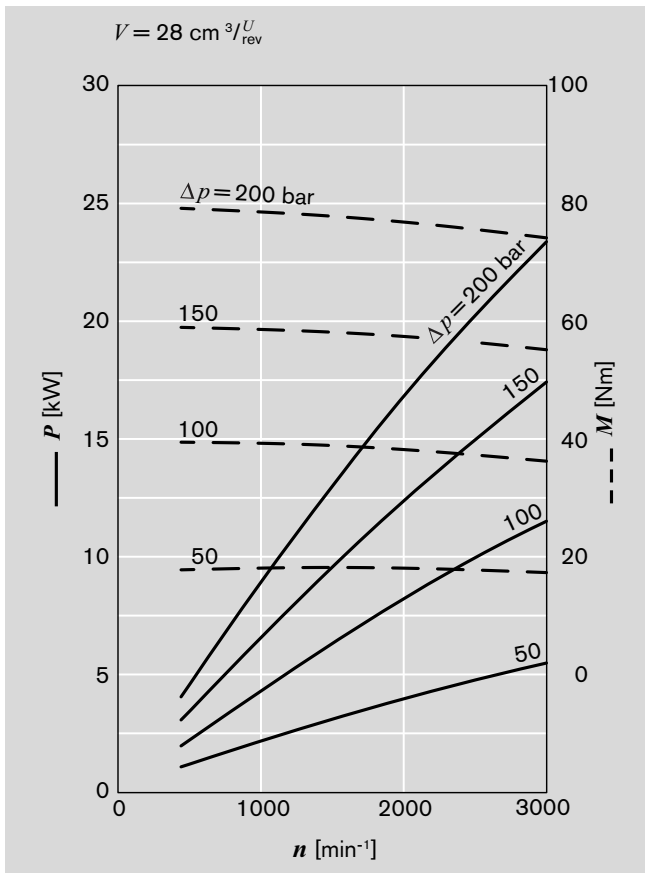
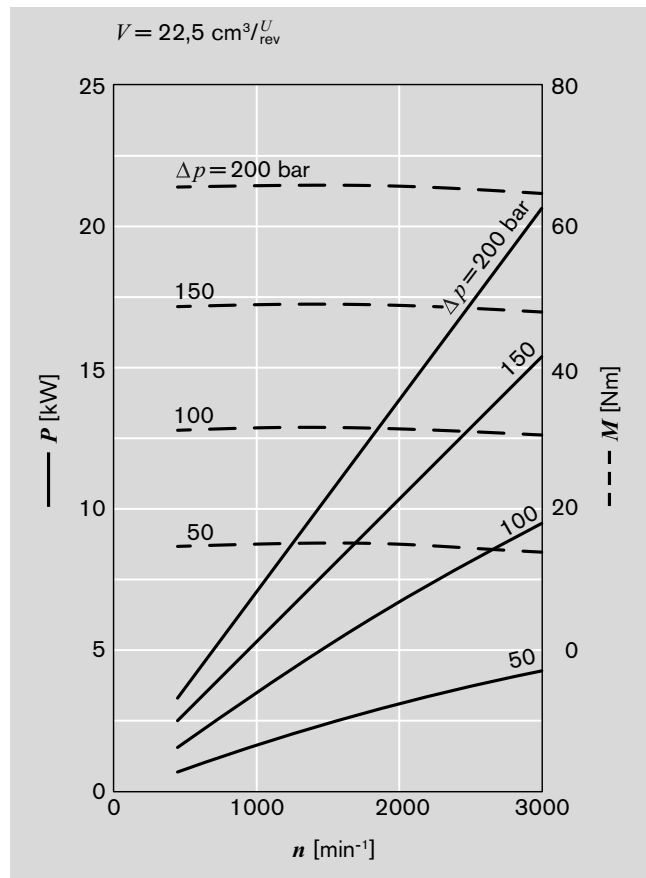
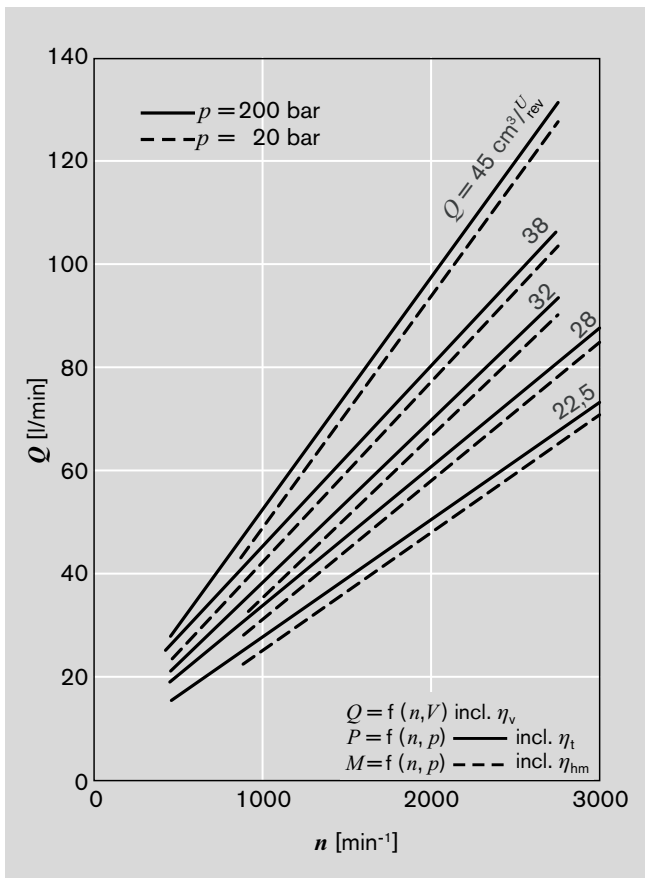

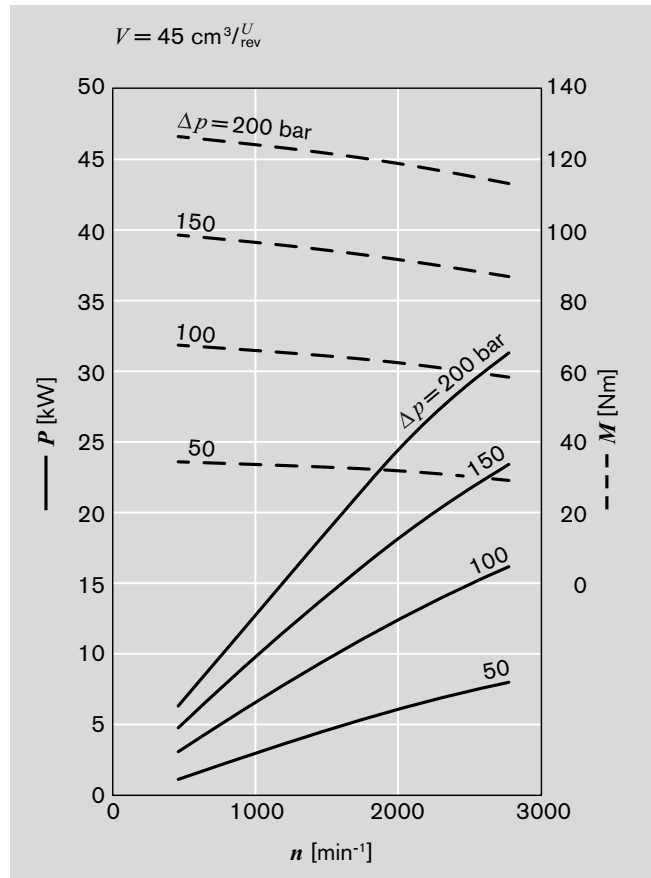
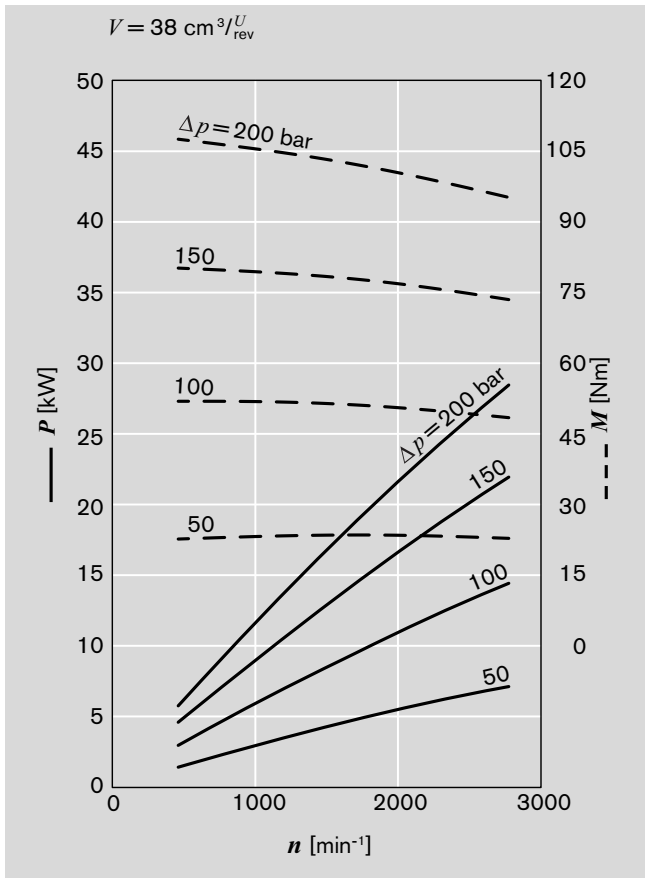

Specifications

General	
Construction	external gear motor
Mounting	Flange or through-bolting with spigot
Port connections	screw, flange
Direction of rotation (looking on shaft)	One direction of rotation or reversible
Mounting position	any
Load on shaft	radial and axial forces after consulting
Ambient temperature range	-30 °C...+80 °C with NBR seals*) -20 °C...+110 °C with FPM seals**)
Fluids	mineral oil-based hydraulic fluids to DIN/ISO, other fluids upon request
Viscosity	12...800 mm ² /s permitted range 20...100 mm ² /s recommended range ...2,000 mm ² /s permitted for starting
Fluid temperature range	max. +80 °C with NBR seals*) max. 110 °C with FPM seals**)
Filter ***)	contamination at least class 19/16 according to ISO 4406 to be obtained with filter b20 = 75. For higher lifespan demands we recommend a correspondingly higher filter class.

*) NBR = Perbunan®
 **) FPM = Viton®
 ***) During the application of control systems or devices with critical counter-reaction, such as steering and brake valves, the type of filtration selected must be adapted to the sensitivity of these devices/systems.

Safety requirements pertaining to the whole systems are to be observed.

In the case of applications with frequent load cycles please consult us.

Model F

Displacement	cm ³ /rev	5.5 ¹⁾	8	11	14	16	19	22.5	
max. continuous pressure p_1	bar	250						180	
max. starting pressure p_2		280						210	
min. rotational speed	min ⁻¹	500							
max. rotational speed p_1		4,000		3,500	3,000				
Motor outlet pressure p_A Leakage-oil line pressure p_L	bar								

Model N

Displacement	cm ³ /rev	25	28
max. continuous pressure p_1	bar	210	200
max. starting pressure p_2		240	230
min. rotational speed	min ⁻¹	500	
max. rotational speed p_1		3,000	
Motor outlet pressure p_A Leakage-oil line pressure p_L	bar		

Model G

Displacement	cm ³ /rev	22.5	28	32	38	45
max. continuous pressure p_1	bar	180				
max. starting pressure p_2		210				
min. rotational speed	min ⁻¹	500				
max. rotational speed p_1		3,000	2,800		2,600	
Motor outlet pressure p_A Leakage-oil line pressure p_L	bar					

1) On request *) Short-term when starting 10 bar

drive shaft

counter-clockwise rotation

clockwise rotation

reversible

for one direction of rotation

p_1 max. continuous pressure

p_2 starting pressure (depending on the application, this must be taken into consideration when setting the pressure of the hydraulic system's pressure-relief valve).

Power take-off

1. Flexible couplings

The coupling must not transfer any radial or axial forces to the motor.

The maximum radial run out of shaft spigot is 0.2 mm.

Refer to the fitting instructions provided by the coupling manufacturer for details of the maximum permitted shaft misalignment.

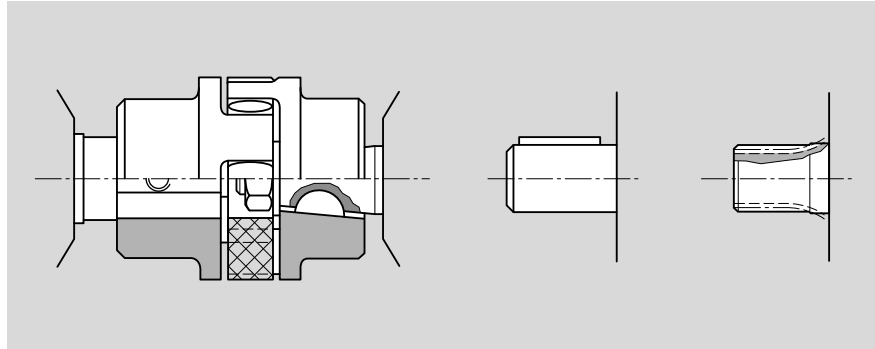

2. Sleeve couplings

Used on shafts with DIN or SAE splining.

Note: There must be no radial or axial forces exerted on the motor or sleeve coupling. The sleeve must be free to move axially. The distance between the motor shaft and drive shaft must be 2^{+1} . Oil-bath or oil-mist lubrication is necessary.

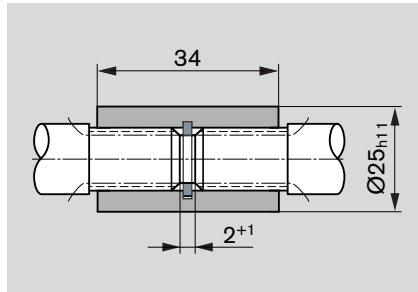

Spline shaft	$M_{max.}$ [Nm]	V [cm ³ /rev]	$p_{max.}$ [bar]
DIN	190	8...22.5	$p_{max.}$
SAE	130		

3. Drive shaft with tang

For the close-coupling of the motors to gearboxes, etc. the motor's shaft has a special drive shaft with tang which combines with a center coupling ③. There is no shaft seal.

The recommended arrangements and dimensions for the drive end and sealing are as follows.

① Drive shaft

Case-hardened steel DIN 17 210, e.g. 20 MnCrS 5 case-hardened 0.6 deep; HRC 60 ±3. Surface for sealing ring ground without rifling $R_{max.} \leq 4\mu\text{m}$

② Radial shaft seal

Rubber-covered seal (see DIN 3760, Type AS or double-lipped ring). Cut 15° chamfer or fit shaft seal with protective sleeve.

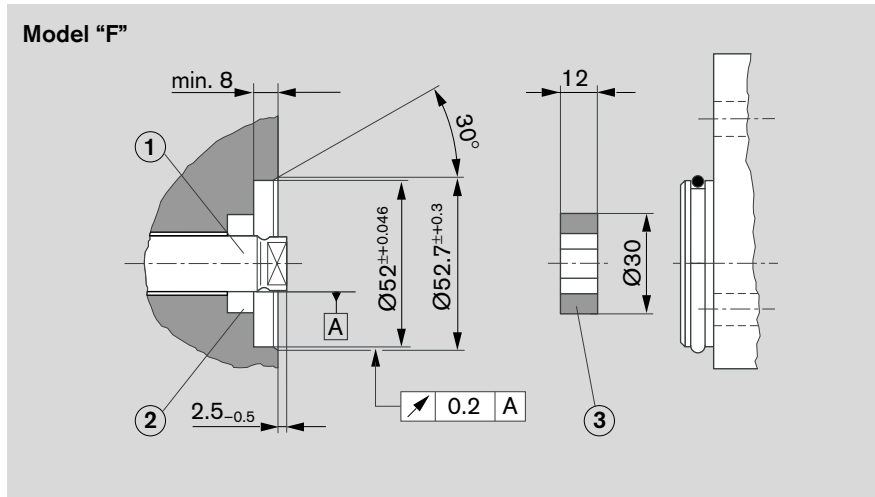

$M_{max.}$ [Nm]	V [cm ³ /rev]	$p_{max.}$ [bar]
65	8...14	280
	16	230
	19	190
	22.5	160

4. Outboard bearing Model "F"

Outboard bearings eliminate possible problems when the motors are driven by V-belts or gearwheels. The diagrams below show the maximum overhung and thrust loads that can be tolerated, referring to a bearing life of $L_H = 1,000$ hours.

$M_{max.}$ [Nm]	V [cm ³ /rev]	$p_{max.}$ [bar]
65	16	230
	19	190
	22.5	160

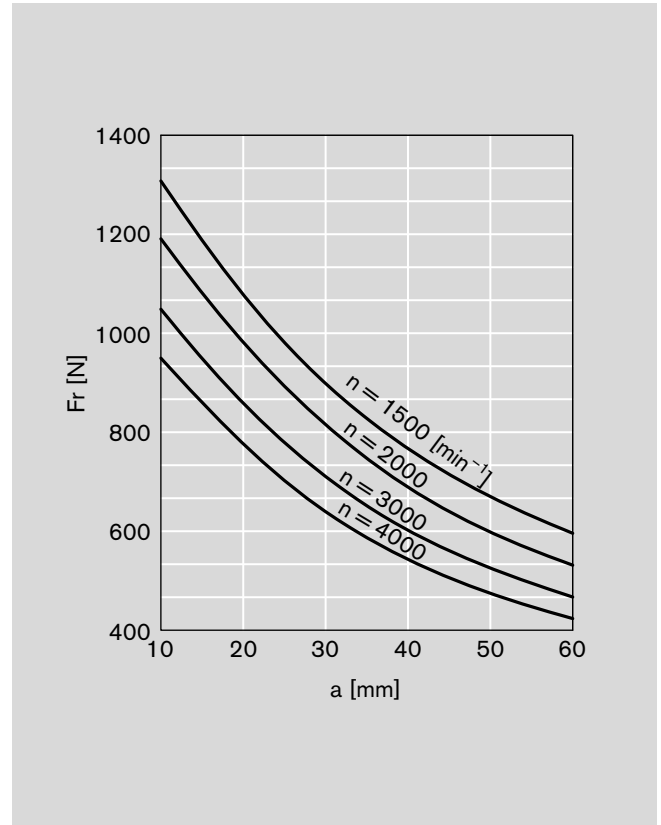
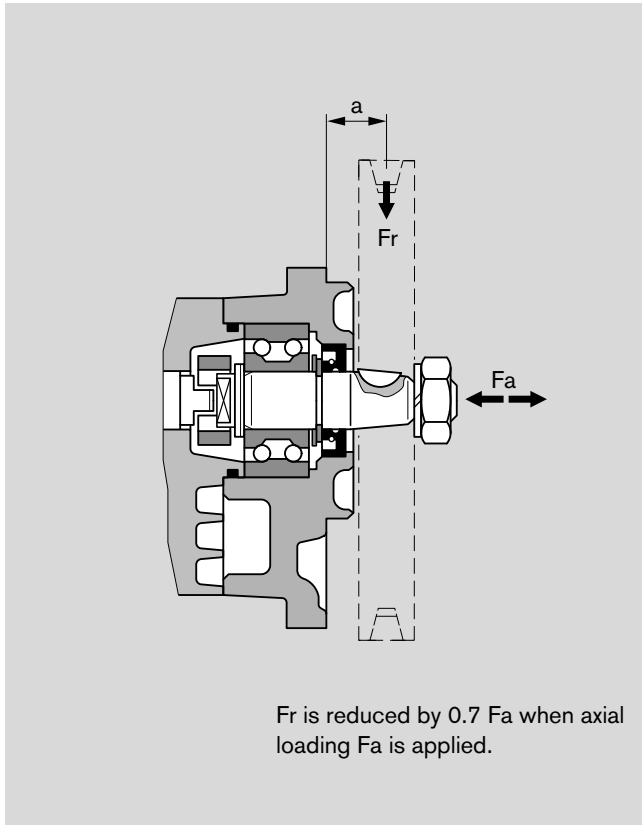

Connectors

Gear motor flange, 3-bolt, 90° angle, for square flange **30** see page 8

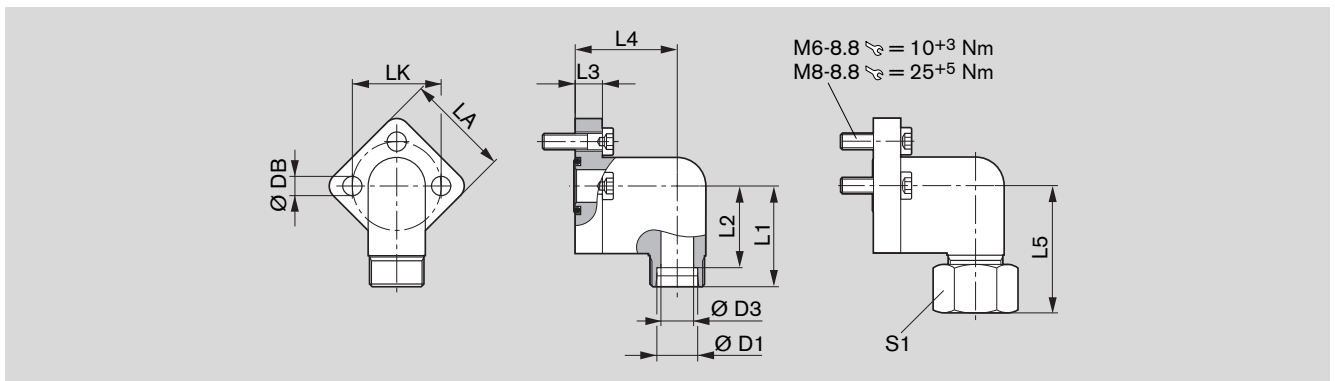

LK	D1	D3	L1	L2	L3	L4	L5	LA	S1	DB	Screws 3 pieces	O-ring NBR *)	Weight [kg]	Ordering-No.	p [bar]
30	12L	10	37	30.0	10	37.5	46	38	22	6.4	M6x22	16x2.5	0.13	1 515 702 146	250
30	15L	12	37	30.0	10	37.5	47	38	27	6.4	M6x22	16x2.5	0.14	1 515 702 147	250
30	18L	15	37	30.0	10	37.5	47	38	32	6.4	M6x22	16x2.5	0.17	1 515 702 148	160
40	22L	19	43	35.5	14	41.0	53	48	36	8.4	M8x30	24x2.5	0.29	1 515 702 149	160
40	28L	24	43	35.5	14	41.0	53	48	41	8.4	M8x30	24x2.5	0.40	1 515 702 150	160

Complete screw connection with O-ring, metric screw set, nut/mother and sleeve fitting *) NBR = Perbunan®

Connectors (continuation)

Gear motor flange, straight, for square flange **20** see page 8

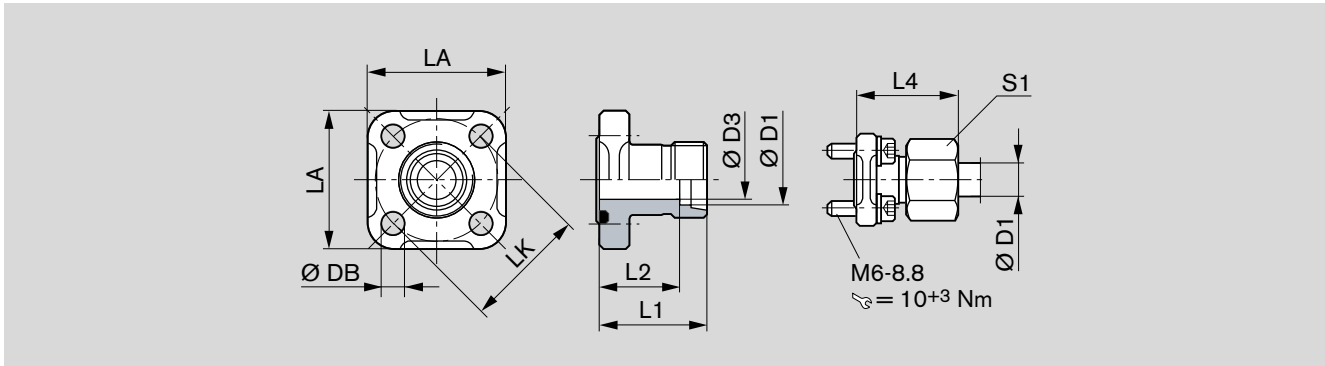

LK	D1	D3	L1	L2	L4	LA	S1	DB	Screws 4 pieces	O-ring NBR *)	Weight [kg]	Ordering-No.	p [bar]
35	10L	8	30	23.0	39.0	40	19	6.4	M6x22	20x2.5	0.09	1 515 702 064	315
35	12L	10	30	23.0	39.0	40	22	6.4	M6x22	20x2.5	0.10	1 515 702 065	315
35	15L	12	30	23.0	38.0	40	27	6.4	M6x22	20x2.5	0.10	1 515 702 066	250
40	15L	12	35	28.0	43.0	42	27	6.4	M6x22	24x2.5	0.12	1 515 702 067	100
40	18L	15	35	27.5	44.0	42	32	6.4	M6x22	24x2.5	0.13	1 515 702 068	100
40	22L	19	35	27.5	44.5	42	36	6.4	M6x22	24x2.5	0.12	1 515 702 069	100
40	28L	24	42	27.5	34.5	42	41	6.4	M6x22	24x2.5	0.15	1 515 702 008	100

Complete screw connection with O-ring, metric screw set, nut/mother and sleeve fitting *) NBR = Perbunan®

Gear motor flange, 90° angle, for square flange **20** see page 8

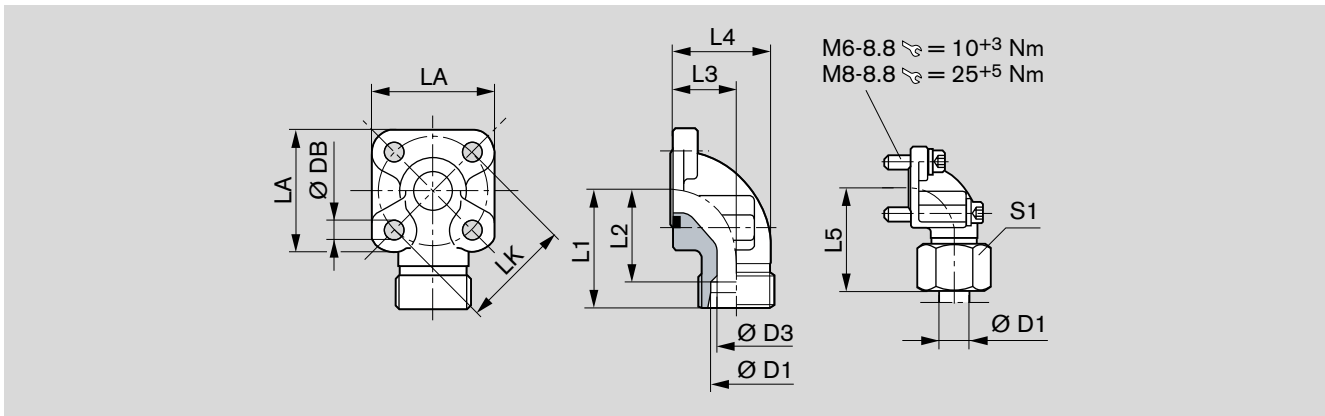

LK	D1	D3	L1	L2	L3	L4	L5	LA	S1	DB	Screws 2 pcs. 2 pcs.	O-ring NBR *)	Weight [kg]	Ordering-No.	p [bar]
35	10L	8	38	31.0	16.5	26.5	47.0	40	19	6.4	M6 x 22 M6 x 35	20 x 2.5	0.16	1 515 702 070	315
35	12L	10	38	31.0	16.5	26.5	47.0	40	22	6.4	M6 x 22 M6 x 35	20 x 2.5	0.16	1 515 702 071	315
35	15L	12	38	31.0	16.5	26.5	46.0	40	27	6.4	M6 x 22 M6 x 35	20 x 2.5	0.15	1 515 702 072	250
35	16S	12	38	29.5	20.0	31.0	48.0	40	30	6.4	M6 x 22 M6 x 40	20 x 2.5	0.18	1 515 702 002	315
35	18L	15	38	29.5	20.0	31.0	47.0	40	32	6.4	M6 x 22 M6 x 40	20 x 2.5	0.18	1 545 702 006	250
35	20S	16	45	34.5	25.0	38.0	56.0	40	36	6.4	M6 x 22 M6 x 45	20 x 2.5	0.24	1 515 702 017	315
40	15L	12	38	31.0	22.5	36.5	46.0	42	27	6.4	M6 x 22 M6 x 22	24 x 2.5	0.15	1 515 702 076	100
40	18L	15	38	30.5	22.5	36.5	47.0	42	32	6.4	M6 x 22 M6 x 22	24 x 2.5	0.17	1 515 702 074	100
40	20S	16	40	29.5	22.5	35.5	50.0	42	36	6.4	M6 x 22 M6 x 45	24 x 2.5	0.20	1 515 702 011	250
40	22L	19	38	30.5	22.5	36.5	47.5	42	36	6.4	M6 x 22 M6 x 22	24 x 2.5	0.17	1 515 702 075	100
40	28L	22	40	32.5	28.0	43.0	49.0	42	41	6.4	M6 x 20 M6 x 50	24 x 2.5	0.24	1 515 702 010	100
40	35L	31	41	30.5	34.0	55.0	52.0	42	50	6.4	M6 x 22 M6 x 60	24 x 2.5	0.33	1 515 702 018	100
55	20S	17	45	34.5	24.0	40.0	56.0	58	36	8.4	M8 x 25 M8 x 50	33 x 2.5	0.44	1 515 702 004	250
55	30S	26	49	35.5	32.0	50.0	62.0	58	50	8.4	M8 x 25 M8 x 50	33 x 2.5	0.50	1 515 702 006	250
55	35L	31	49	38.5	32.0	51.5	62.0	58	50	8.4	M8 x 25 M8 x 60	33 x 2.5	0.47	1 515 702 005	100
55	42L	38	49	38.0	40.0	64.5	61.0	58	60	8.4	M8 x 25 M8 x 70	33 x 2.5	0.60	1 515 702 019	100

Complete screw connection with O-ring, metric screw set, nut/mother and sleeve fitting *) NBR = Perbunan®

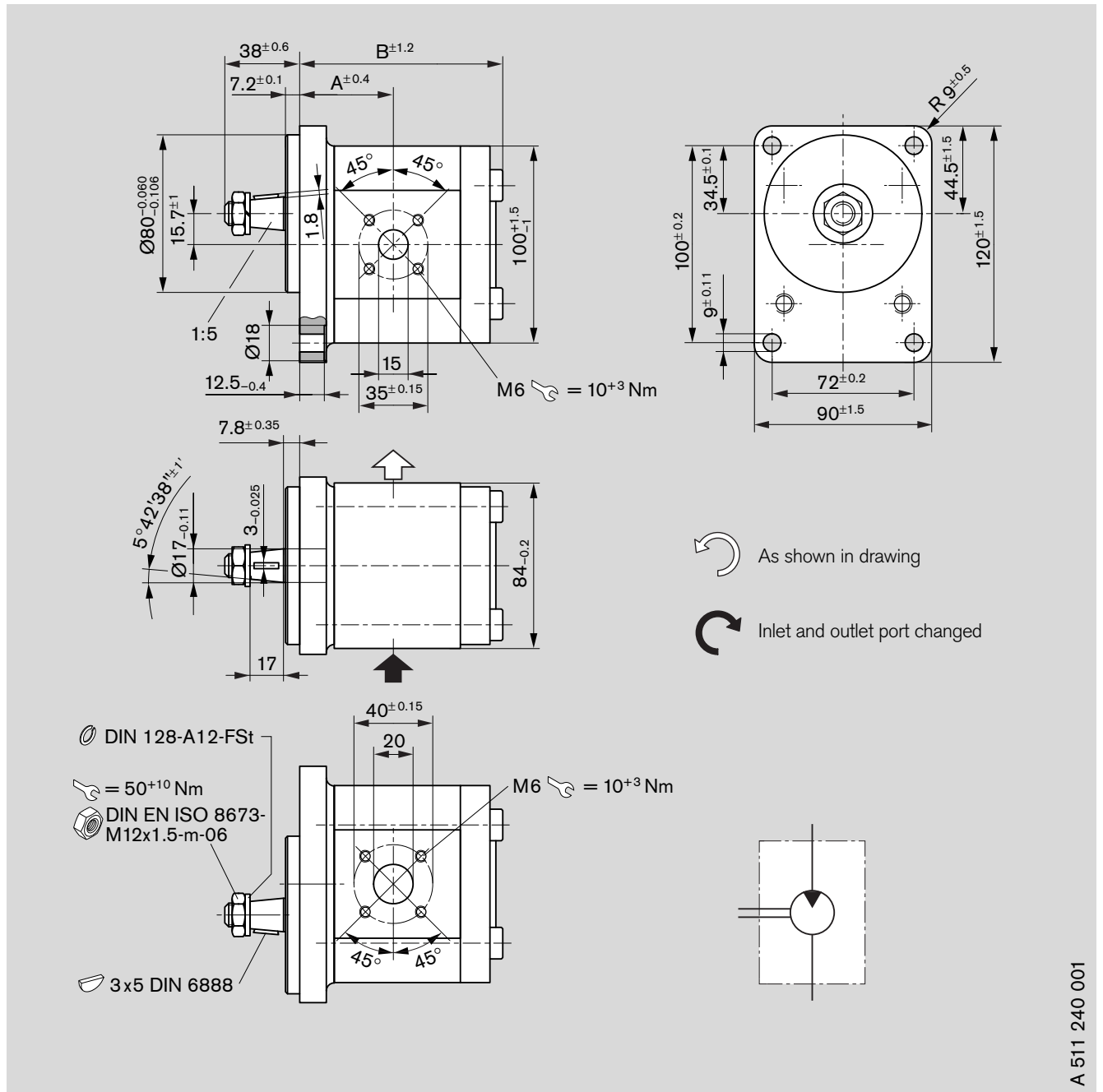

Dimensions in mm

F-Motor



Ordering code

- AZMF - 1x - C B 20 M B
- AZMF - 10 - C B 20 K B*
- AZMF - 10 - C B 20 M B - S0012 **

Displacement [cm ³ /rev]	Ordering-No.		Max. operating pressure [bar]	Min. rotation speed [min ⁻¹]	Max. rotation speed [min ⁻¹]	kg	Dimension [mm]	
	 L	 R					A	B
8	0 511 425 300	0 511 425 001	210	500	4,000	2.9	43.2	91.1
11	0 511 525 300	0 511 525 001	210	500	3,500	3.0	47.0	96.3
14	0 511 525 304	-	210	500	3,000	3.2	47.5	101.3
16	-	0 511 625 005	210	500	3,000	3.4	47.5	104.7
19	0 511 625 308	0 511 625 003	180	500	3,000	3.6	47.5	109.7
19	-	0 511 625 009 *	180	500	3,000	3.6	47.5	109.7
22.5	0 511 725 304 **	0 511 725 005 **	210	500	3,000	3.9	61.1	125.3

Dimensions in mm

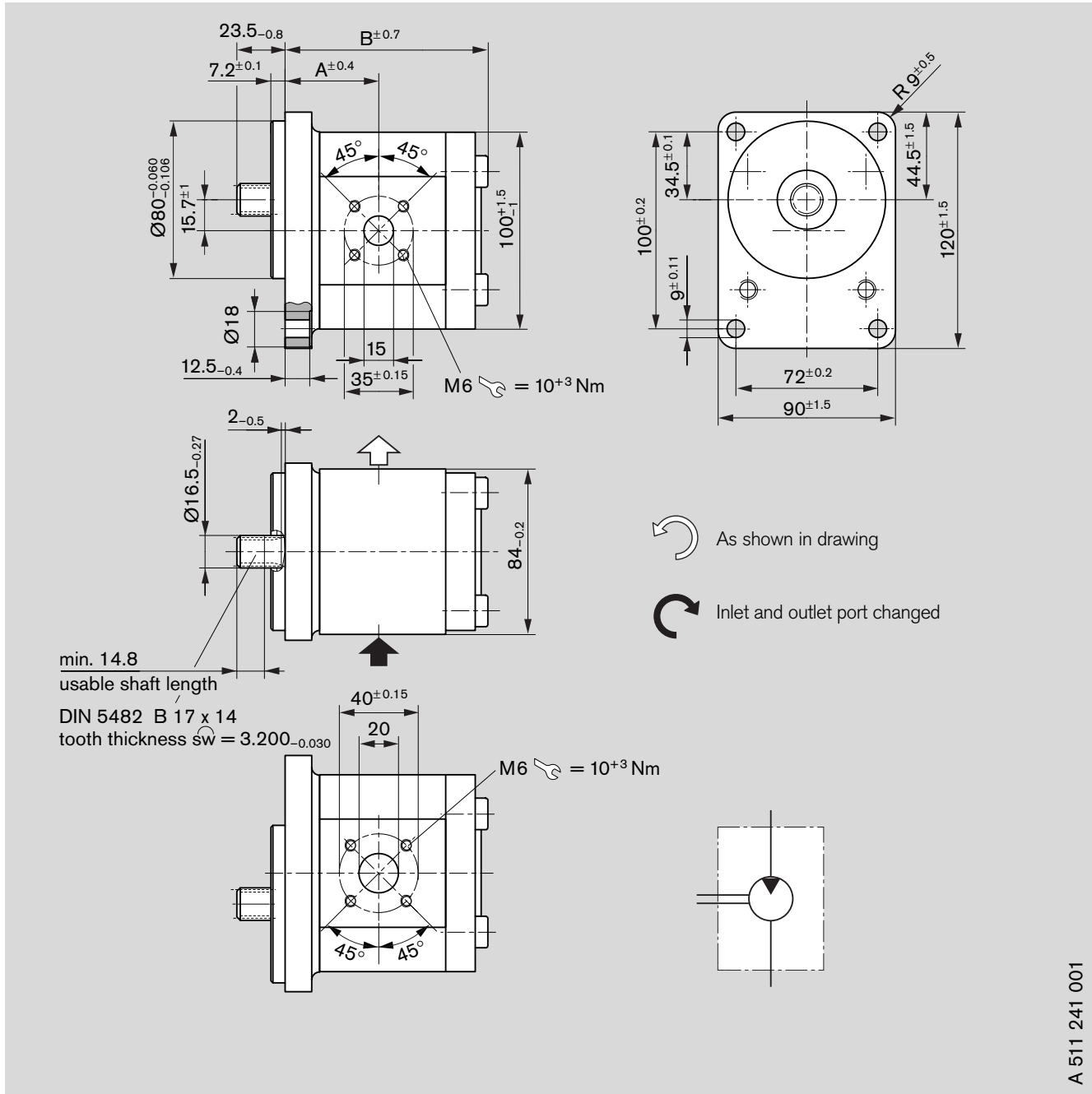

F-Motor



A 511 241 001

Ordering code

AZMF - 10 - F B 20 M B

Displacement [cm ³ /rev]	Ordering-No.		Max. operating pressure [bar]	Min. rotation speed [min ⁻¹]	Max. rotation speed [min ⁻¹]	kg	Dimension [mm]	
	 L	 R					A	B
8	0 511 425 301	0 511 425 002	210	500	4,000	2.9	43.2	91.0
11	0 511 525 301	0 511 525 002	210	500	3,500	3.0	47.0	96.0
14	0 511 525 303	-	210	500	3,000	3.2	47.5	101.0
16	0 511 625 301	0 511 625 001	210	500	3,000	3.4	47.5	104.4
19	0 511 625 300	0 511 625 002	180	500	3,000	3.6	47.5	109.4
22.5	0 511 725 303	0 511 725 004	180	500	3,000	3.8	61.1	126.8

Dimensions in mm

F-Motor

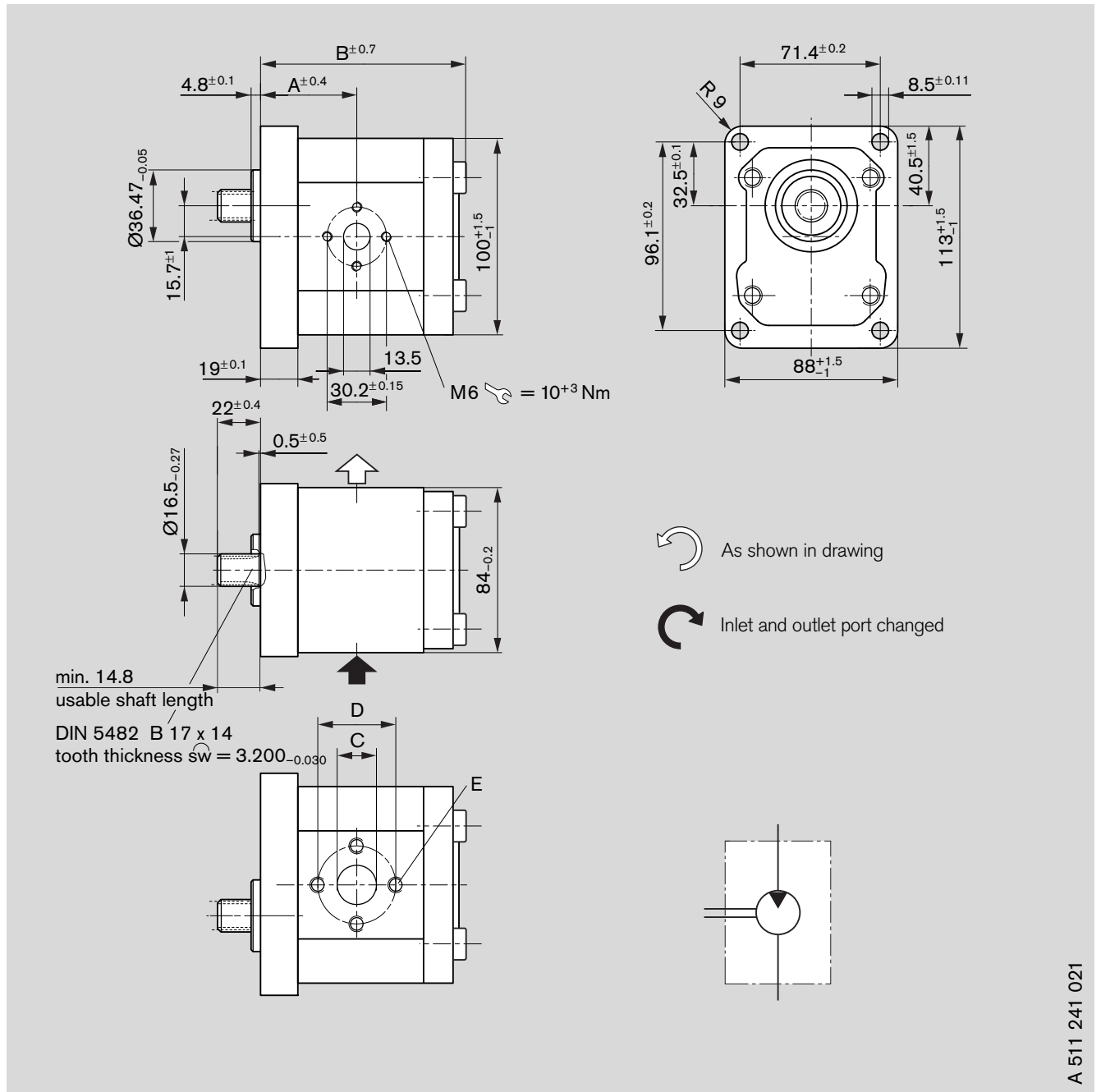

A 511 241 021

Ordering code

AZMF - 10 - F O 30 M B

Displacement [cm ³ /rev]	Ordering-No.		Max. operating pressure [bar]	Min. rotation speed [min ⁻¹]	Max. rotation speed [min ⁻¹]	kg	Dimension [mm]				
	L	R					A	B	C	D	E
8	-	0 511 425 003	210	500	4,000	2.9	44.9	90.7	13.5	30.2	M6 = 10 ⁺³
19	0 511 625 303	-	180	500	3,000	3.7	49.0	109.1	20.0	39.7	M8 = 25 ⁺⁵
22.5	-	0 511 725 305	180	500	3,000	3.9	56.6	114.5	20.0	39.7	M8 = 25 ⁺⁵

Dimensions in mm

F-Motor

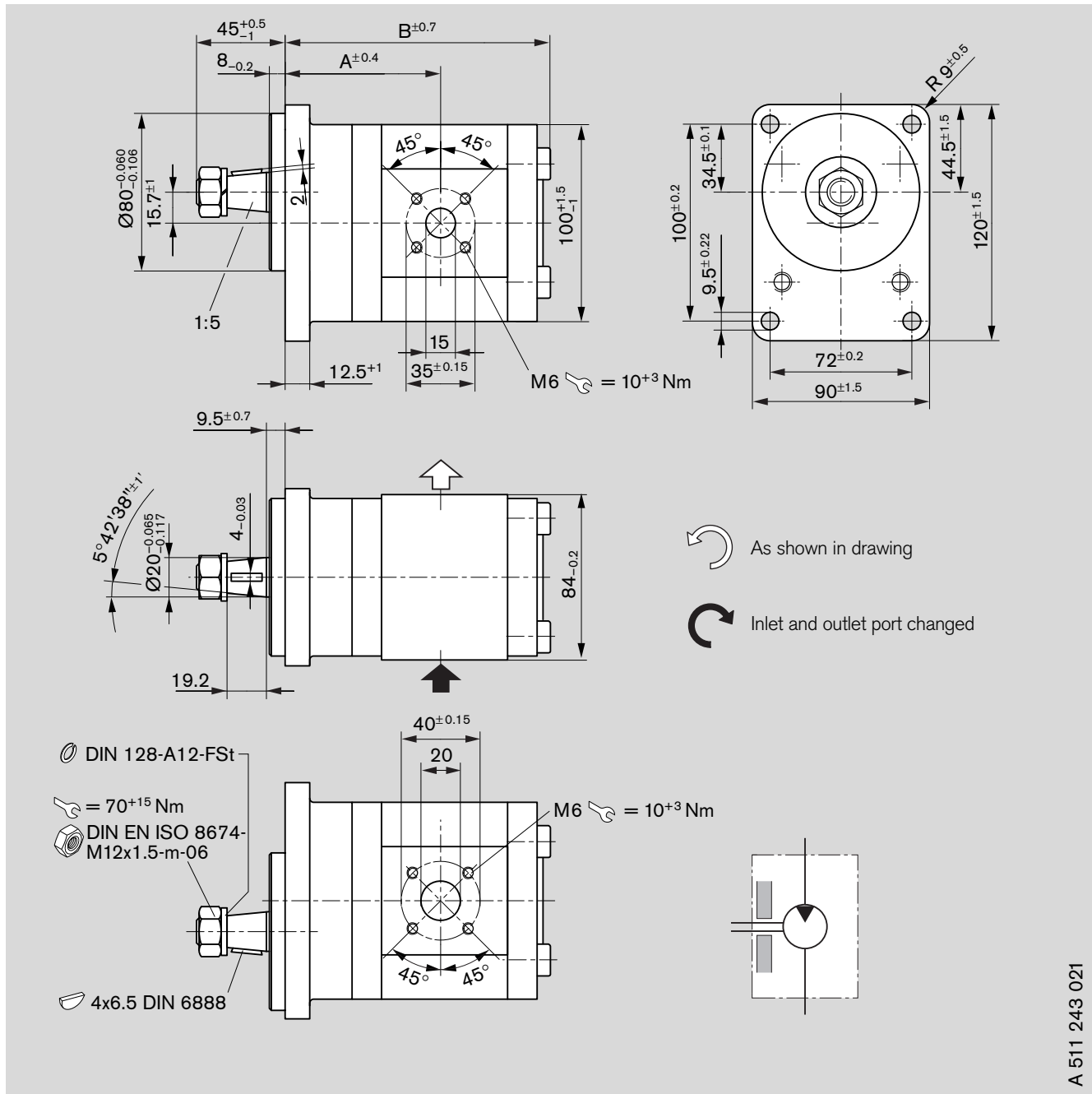

Ordering code

AZMF - 10 - S A 20 M B
 AZMF - 10 - S A 20 M B - S0012

Displacement [cm ³ /rev]	Ordering-No.		Max. operating pressure [bar]	Min. rotation speed [min ⁻¹]	Max. rotation speed [min ⁻¹]	kg	Dimension [mm]	
	L	R					A	B
8	0 511 445 300	0 511 445 001	250	500	4,000	3.5	74.7	120.6
11	0 511 545 300	0 511 545 001	250	500	3,500	3.6	78.5	125.6
14	0 511 545 301	-	250	500	3,000	3.7	79.0	130.6
16	0 511 645 300	0 511 645 001	250	500	3,000	3.8	79.0	134.0
16	-	0 511 645 003	230	500	3,000	3.8	93.0	134.0
19	0 511 645 302	-	190	500	3,000	4.2	79.0	139.0
22.5	0 511 745 300*	0 511 745 001*	160	500	2,500	4.8	92.6	156.4

Dimensions in mm

F-Motor

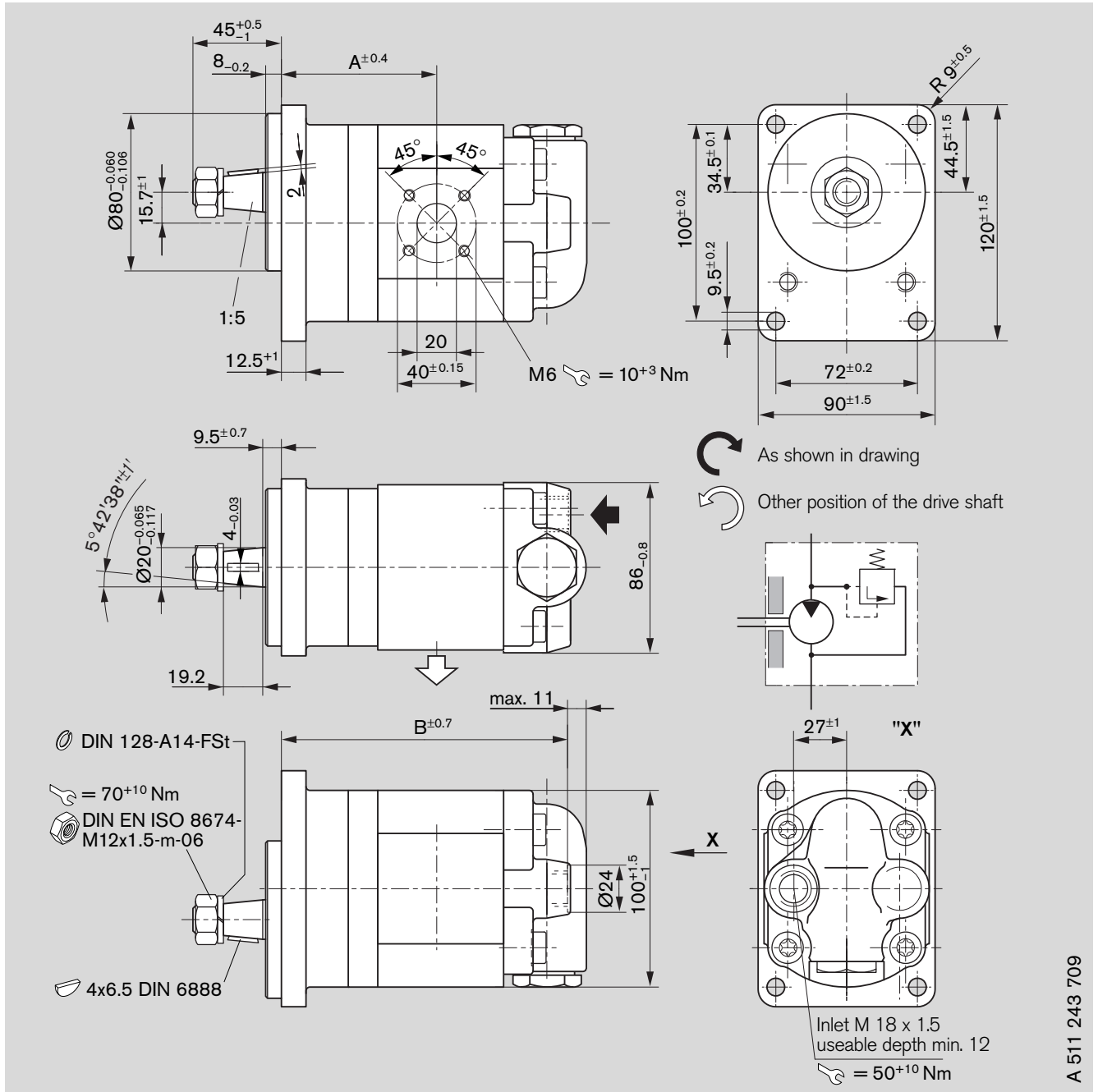

Ordering code

AZMF - 10 - S A 20 M D XXXXX - S0076

Displacement [cm³/rev]	Ordering-No.		Max. operating pressure [bar]	Min. rotation speed [min⁻¹]	Max. rotation speed [min⁻¹]	kg	Dimension [mm]	
	L	R					A	B
8	0 511 445 301	0 511 445 003	200	500	4,000	3.6	74.7	133.1
11	0 511 545 302	0 511 545 003	150	500	3,500	3.8	79.1	138.1

Dimensions in mm

F-Motor

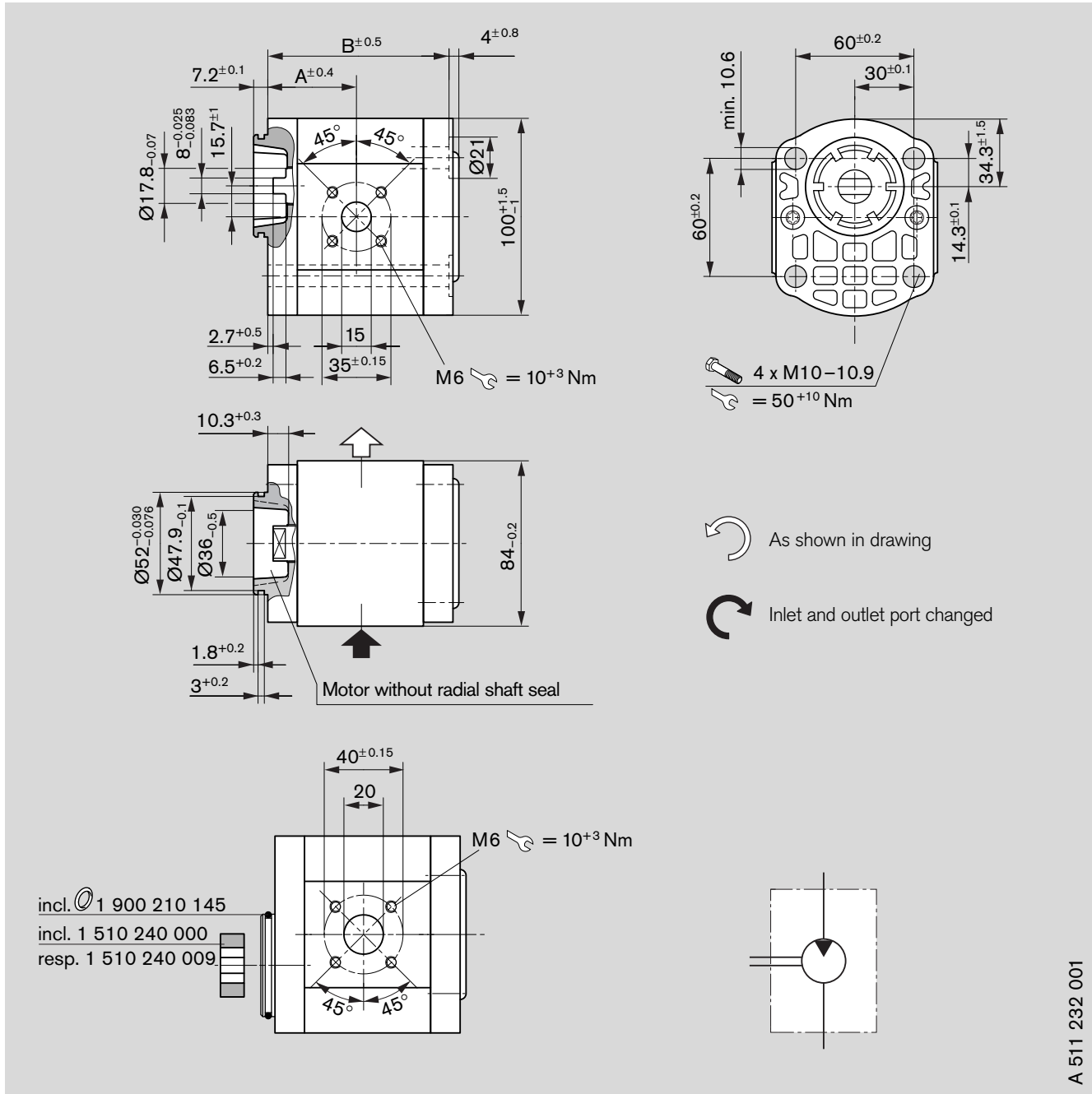

Ordering code
AZMF - 10 - **NT 20 MB**

Displacement [cm ³ /rev]	Ordering-No.		Max. operating pressure [bar]	Min. rotation speed [min ⁻¹]	Max. rotation speed [min ⁻¹]	kg	Dimension [mm]	
	L	R					A	B
8	0 511 415 300	0 511 415 001	250	500	4,000	2.5	40.7	80.3
11	0 511 515 300	0 511 515 001	250	500	3,500	2.6	44.5	85.3
16	0 511 615 301	0 511 615 002	230	500	3,000	3.0	45.0	93.7
19	0 511 615 300	0 511 615 001	190	500	3,000	3.2	45.0	98.7
22.5	0 511 715 300	0 511 715 001	160	500	3,000	3.4	52.6	104.1

Dimensions in mm

F-Motor

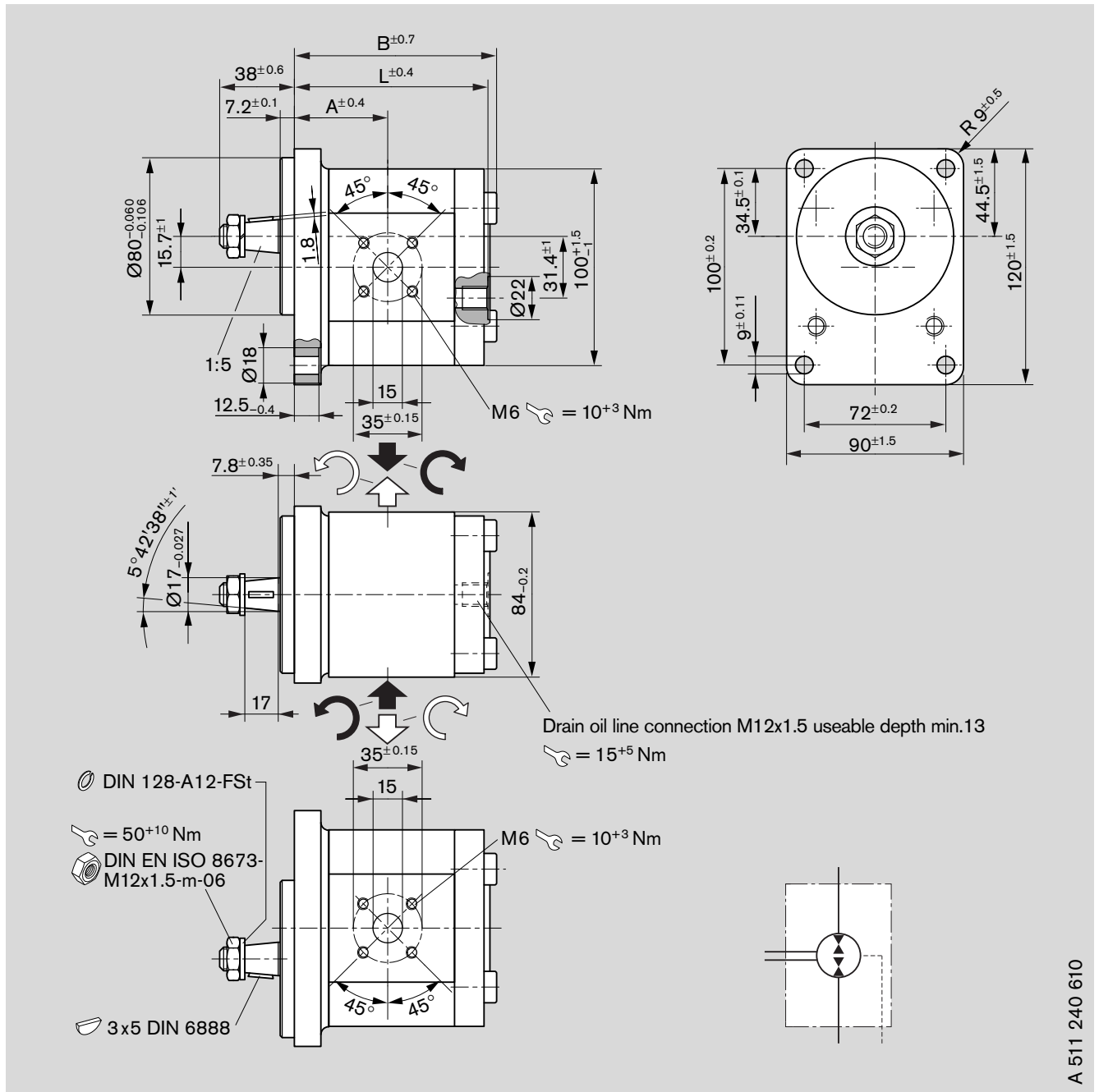

A 511 240 610

Ordering code

AZMF - 10 - UCB 20 M L

AZMF - 10 - UCB 20 K L*

Displacement [cm ³ /rev]	Ordering-No. Universal	Max. operating pressure [bar]	Min. rotation speed [min ⁻¹]	Max. rotation speed [min ⁻¹]	kg	Dimension [mm]		
						A	B	L
8	0 511 425 601	210	500	4,000	3.4	43.2	90.7	85.8
11	0 511 525 604	210	500	3,500	4.2	47.0	95.9	90.8
16	0 511 625 602	210	500	3,000	3.9	47.5	104.3	99.2
22.5	0 511 725 601 *	180	500	3,000	3.9	55.1	114.6	109.6

Dimensions in mm

F-Motor

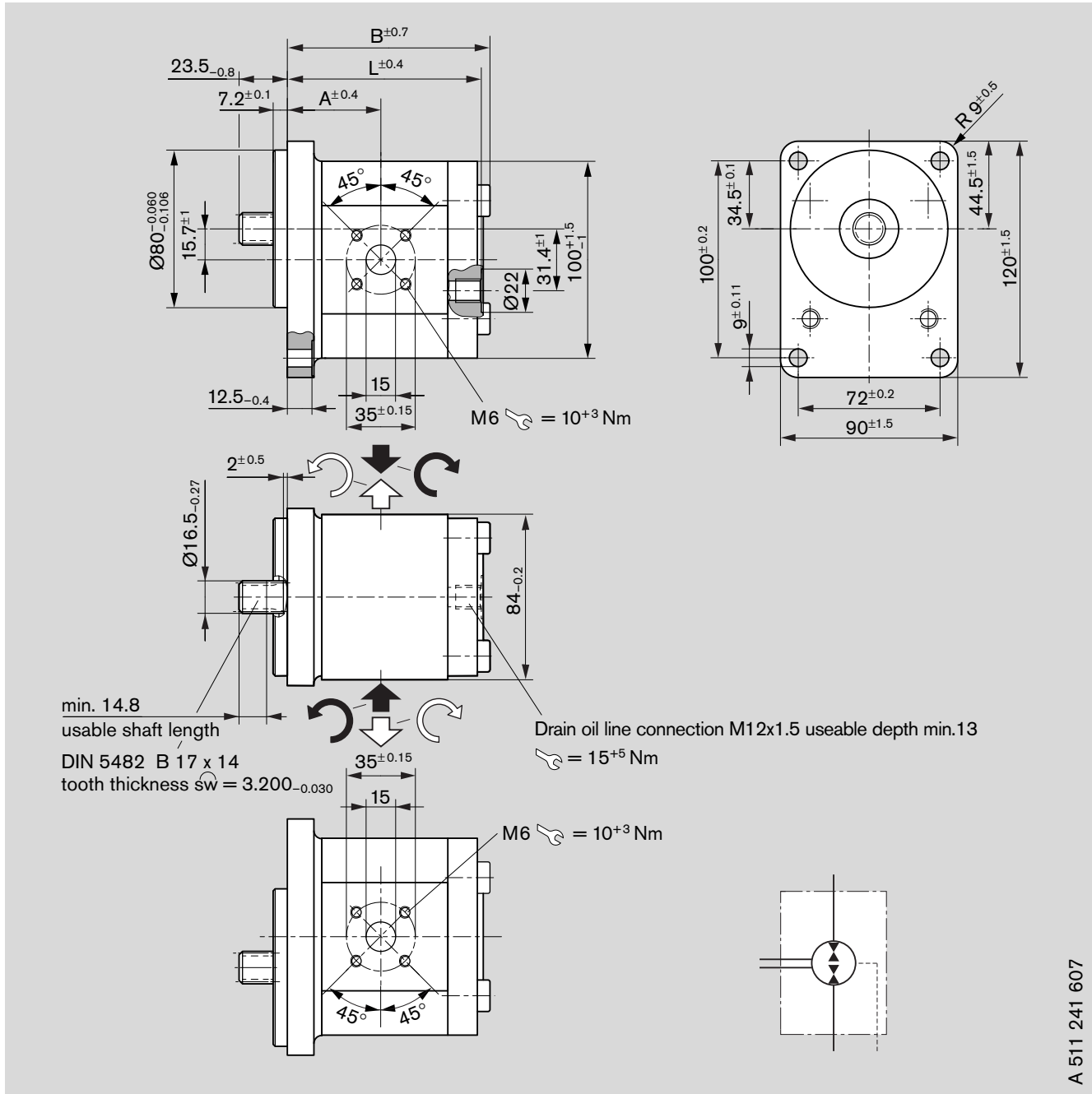

Ordering code

AZMF - 10 - U F B 20 M L

Displacement [cm ³ /rev]	Ordering-No. Universal	Max. operating pressure [bar]	Min. rotating speed [min ⁻¹]	Max. rotating speed [min ⁻¹]	kg	Dimension [mm]		
						A	B	L
8	0 511 425 603	210	500	4,000	2.9	43.2	91.0	85.8
11	0 511 525 601	210	500	3,500	3.0	47.0	96.0	90.8
16	0 511 625 603	210	500	3,000	3.4	47.5	104.4	99.2
19	0 511 625 605	180	500	3,000	3.6	47.5	109.4	104.2
22.5	0 511 725 602	180	500	3,000	3.8	55.1	114.8	109.6

Dimensions in mm

F-Motor

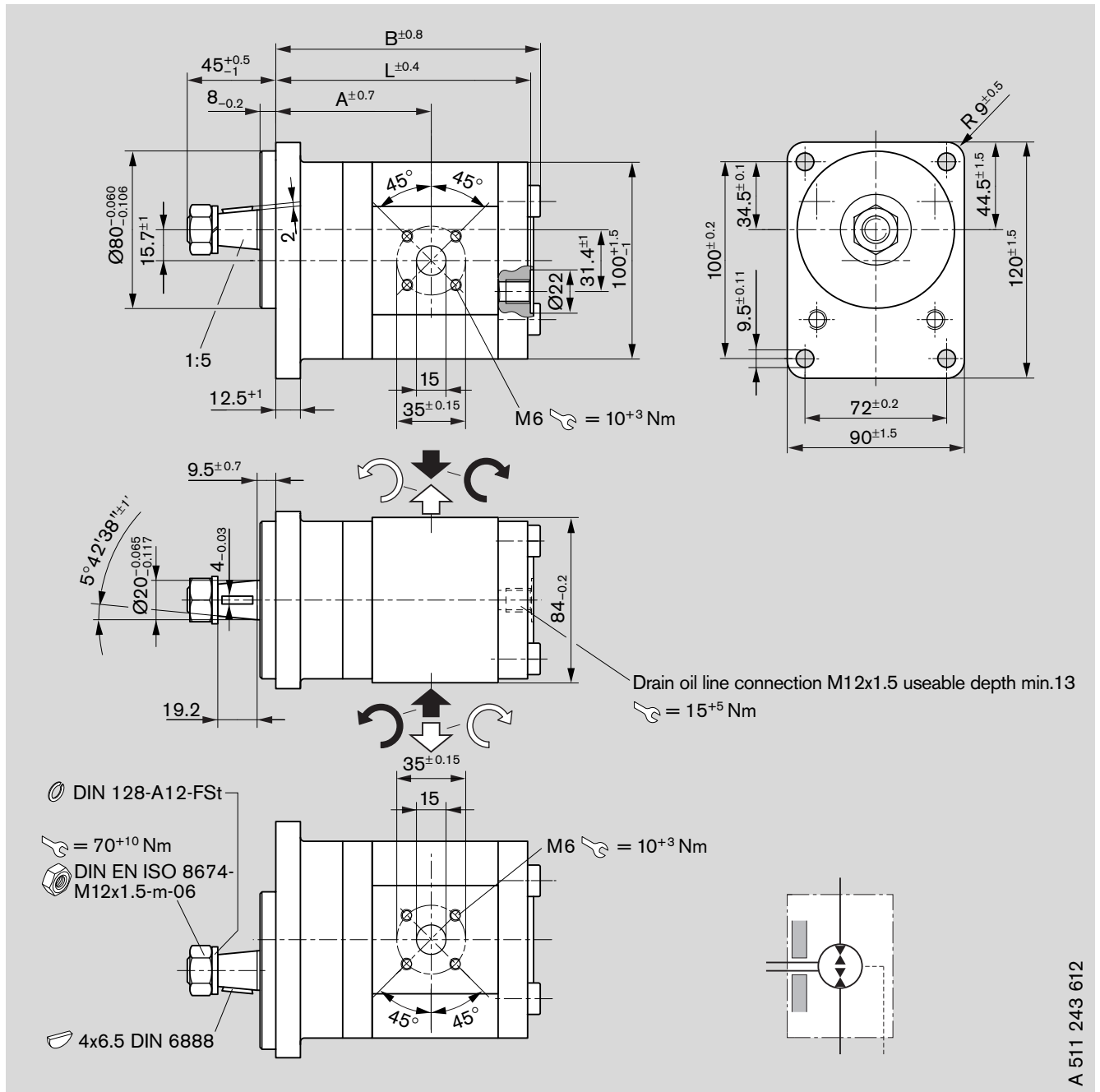

A 511 243 612

Ordering code

AZMF - 10 - U S A 20 M L

Displacement [cm ³ /rev]	Ordering-No. Universal	Max. operating pressure [bar]	Min. rotation speed [min ⁻¹]	Max. rotation speed [min ⁻¹]	kg	Dimension [mm]		
						A	B	L
8	0 511 445 601	250	500	4,000	3.5	74.8	120.8	116.9
11	0 511 545 601	250	500	3,500	3.6	78.6	125.8	121.9
16	0 511 645 601	230	500	3,000	4.0	79.1	134.2	130.3
19	0 511 645 603	190	500	3,000	4.2	79.1	139.2	135.3

Dimensions in mm

F-Motor

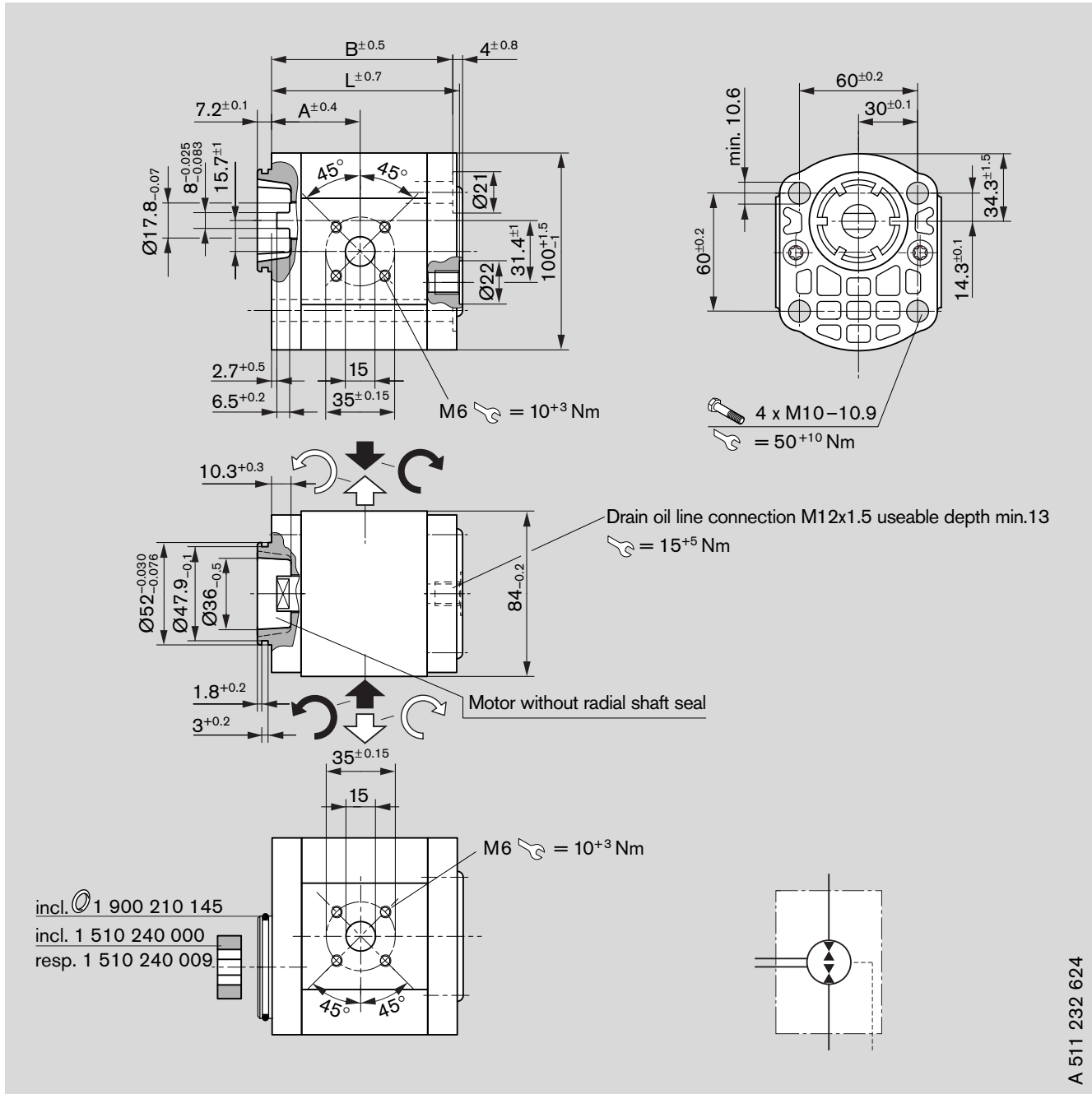

Ordering code

AZMF - 10 - U N T 20 M L - S0164

Displacement [cm ³ /rev]	Ordering-No. Universal	Max. operating pressure [bar]	Min. rotation speed [min ⁻¹]	Max. rotation speed [min ⁻¹]	kg	Dimension [mm]		
						A	B	L
8	0 511 415 605	250	500	4,000	2.5	40.7	80.3	82.8
11	0 511 515 602	250	500	3,500	2.6	44.5	85.3	87.8
16	0 511 615 607	230	500	3,000	3.0	45.0	93.7	96.2
19	0 511 615 608	190	500	3,000	3.2	45.0	98.7	101.2
22.5	0 511 715 601	160	500	3,000	3.4	52.6	104.1	106.6

Dimensions in mm

F-Motor

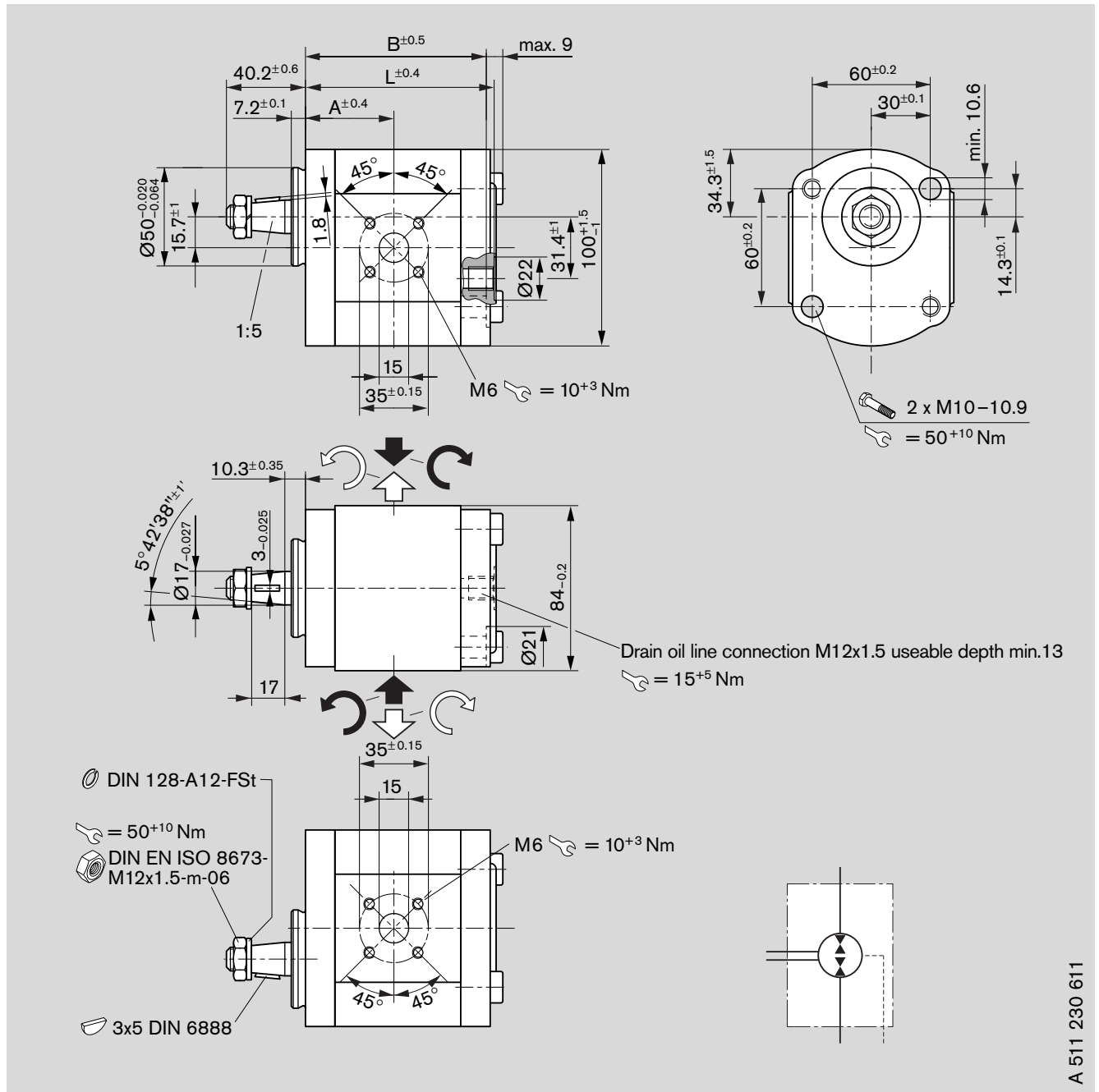

A 511 230 611

Ordering code

AZMF - 1X - UCP 20 ML

Displacement [cm ³ /rev]	Ordering-No. Universal	Max. operating pressure [bar]	Min. rotation speed [min ⁻¹]	Max. rotation speed [min ⁻¹]	kg	Dimension [mm]		
						A	B	L
8	0 511 415 606	210	500	4,000	2.8	40.7	80.3	83.3
11	0 511 515 601	210	500	3,500	2.8	44.5	85.3	88.3
14	0 511 515 605	210	500	3,000	3.1	45.0	90.3	93.3
16	0 511 615 609	210	500	3,000	3.1	45.0	93.7	96.7

Dimensions in mm

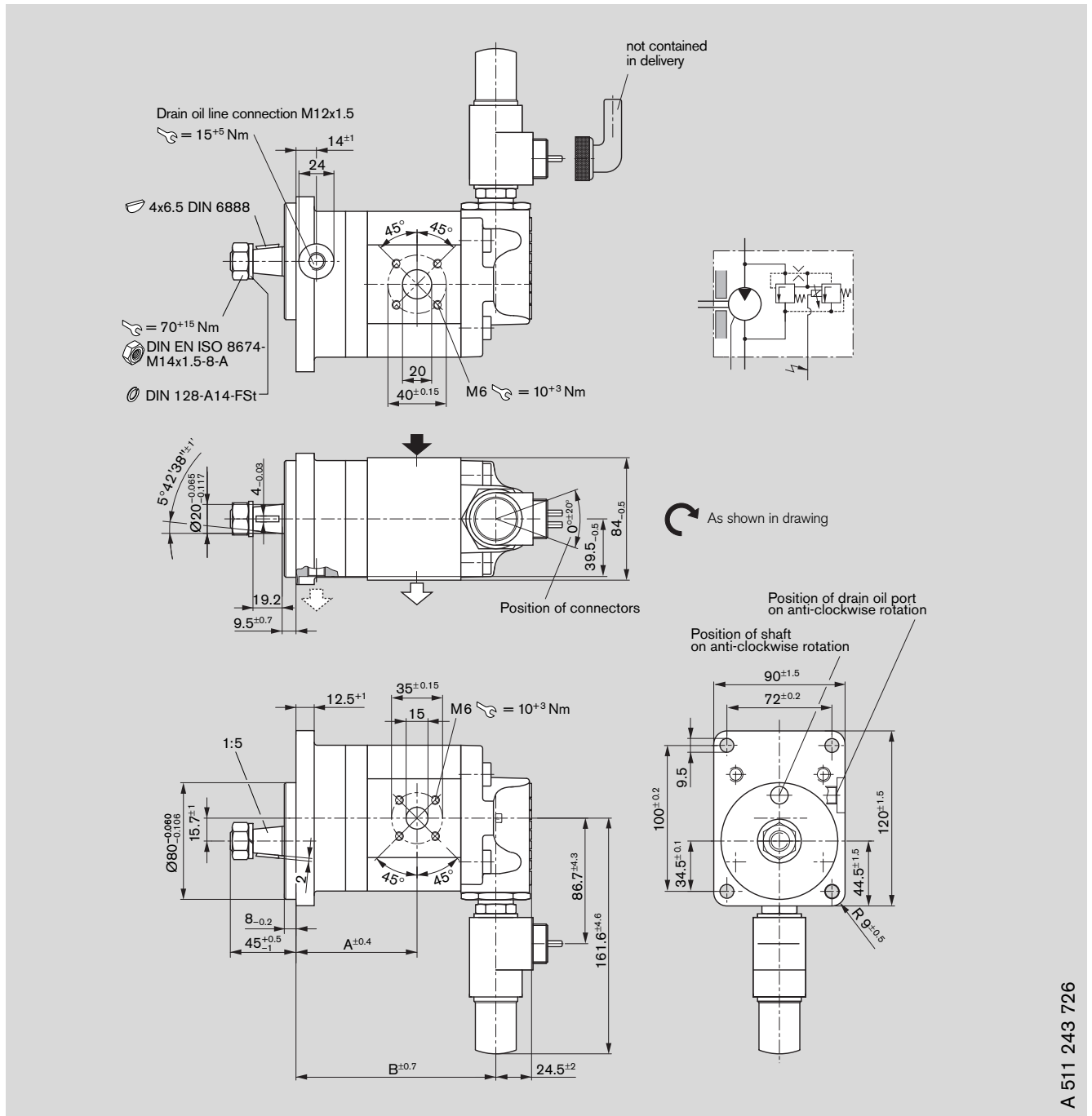

F-Motor



A 511 243 726

Ordering code

AZMF - 11 - S A 20 P GXXXX
 AZMF - 12 - S A 20 P GXXXX*

Displacement [cm ³ /rev]	Ordering-No.		Min. rotation speed [min ⁻¹]	Max. rotation speed [min ⁻¹]	PVR [bar]	Coil nominal current [I]	kg	Dimension [mm]	
	 L	 R						A	B
16	-	0 511 645 007	500	3,000	130	1.5	5.0	79.0	137.7
16	-	0 511 645 005 *	500	3,000	170	1.5	5.0	79.0	137.7
16	0 511 645 306	-	500	3,000	170	1.5	5.1	79.0	137.7
16	0 511 645 307	-	500	3,000	210	1.5	5.1	79.0	137.7
16	-	0 511 645 011 *	500	3,000	210	1.5	5.1	79.0	137.7

Dimensions in mm

F-Motor

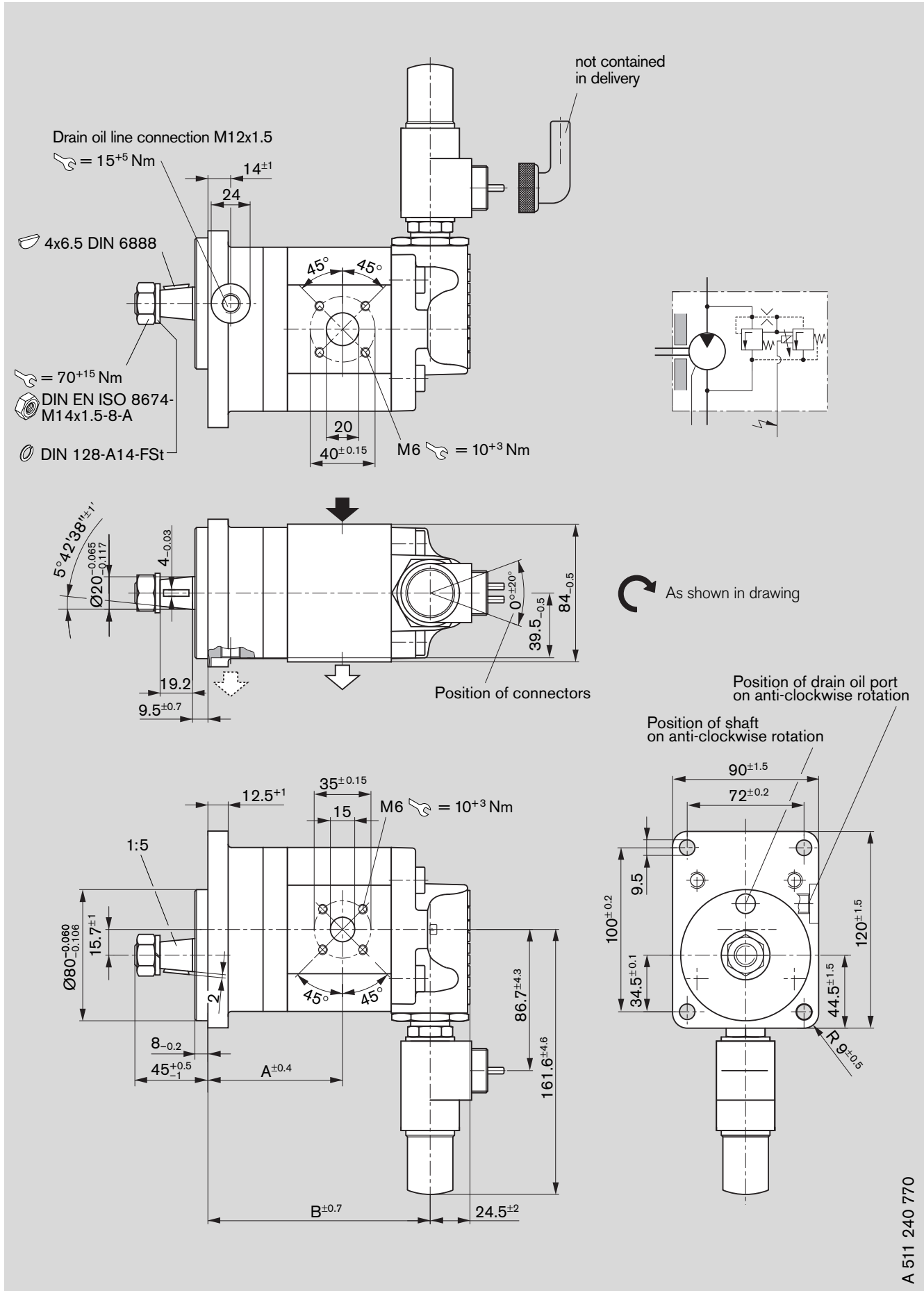



Dimensions in mm

F-Motor

Ordering code

AZMF - 11 - C B 20 P GXXXX

Displacement [cm ³ /rev]	Ordering-No.		Min. rotation speed [min ⁻¹]	Max. rotation speed [min ⁻¹]	PRV [bar]	Coil nominal current [A]	kg	Dimension [mm]	
	 L	 R						A	B
8	0 511 425 302	-	500	4,000	210	0.75	4.7	48.7	98.3
8	-	0 511 425 015	500	4,000	90	1.5	4.6	48.7	98.3
8	-	0 511 425 013	500	4,000	130	1.5	4.7	48.7	98.3
8	-	0 511 425 012	500	4,000	170	1.5	4.7	48.7	98.3
8	-	0 511 425 014	500	4,000	150	1.5	4.7	48.7	98.3
11	-	0 511 525 013	500	3,500	170	1.5	4.7	47.5	103.5
11	-	0 511 525 011	500	3,500	180	0.75	4.8	47.5	103.5
11	0 511 525 309	-	500	3,500	90	1.5	4.8	47.5	103.5
11	0 511 525 308	-	500	3,500	180	0.75	4.8	47.5	103.5
14	-	0 511 525 014	500	3,000	210	1.5	4.9	43.2	108.5
16	-	0 511 625 019	500	3,000	210	1.5	5.0	47.5	111.7
16	0 511 625 309	-	500	3,000	210	1.5	5.0	47.5	111.7
16	-	0 511 625 020	500	3,000	210	0.75	5.0	47.5	111.7
19	-	0 511 625 018	500	3,000	210	1.5	5.1	47.5	116.7
19	-	0 511 625 022	500	3,000	210	0.75	4.0	47.5	116.7
19	-	0 511 625 021	500	3,000	180	0.75	5.1	47.5	116.7
22.5	0 511 725 311	-	500	3,000	210	1.5	5.3	55.1	122.1
22.5	-	0 511 725 021	500	3,000	210	1.5	5.3	55.1	122.1
22.5	-	0 510 725 023	500	3,000	210	0.75	5.3	55.1	122.1
22.5	-	0 511 725 027	500	3,000	170	1.5	5.2	55.1	122.1

Dimensions in mm

F-Motor

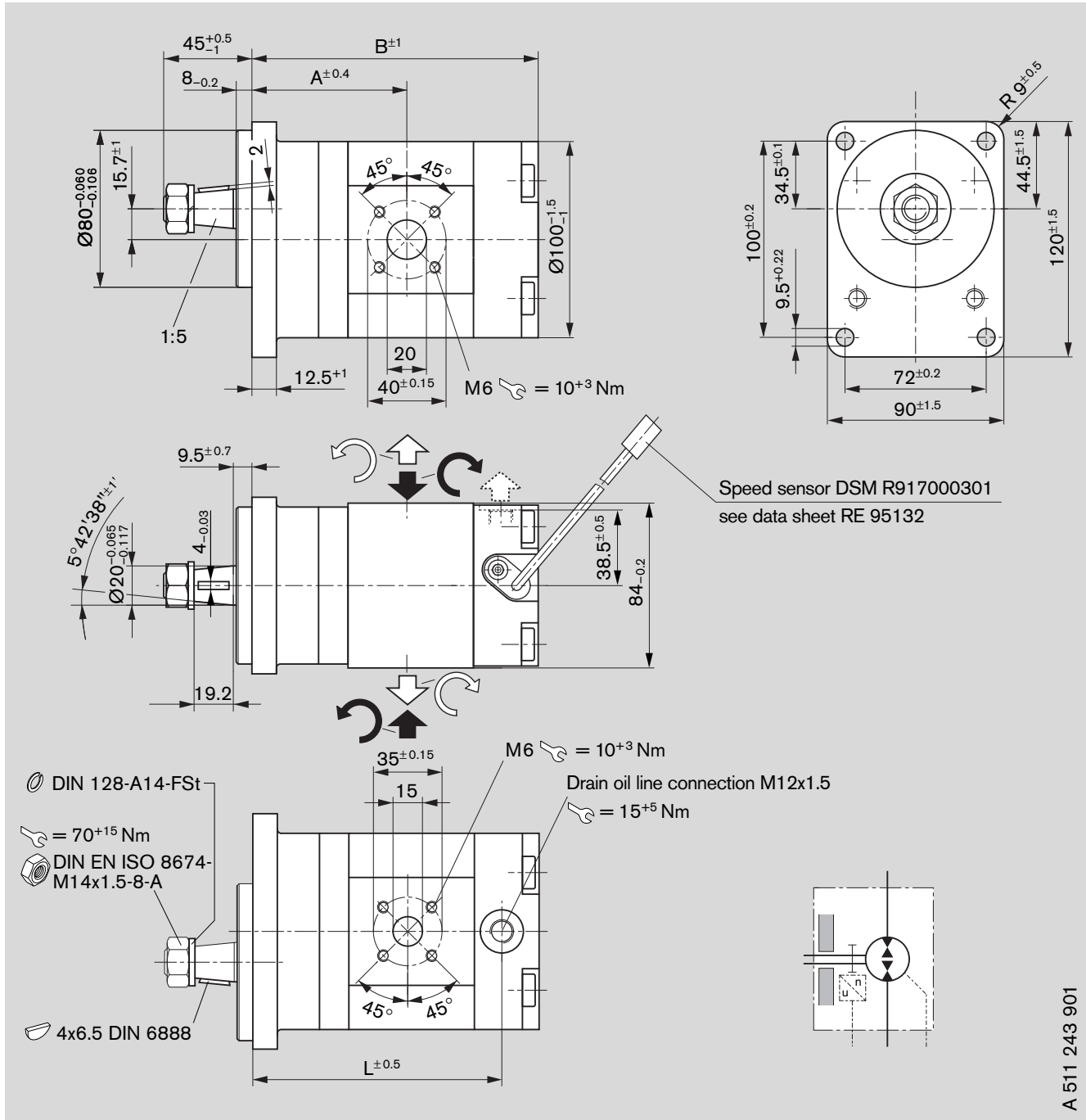

A 511 243 901

Ordering code

AZMF - 12 - U S A 20 P L - S0079

Displacement [cm ³ /rev]	Ordering-No.	Max. operating pressure [bar]	Min. rotation speed [min ⁻¹]	Max. rotation speed [min ⁻¹]	kg	Dimension [mm]		
						A	B	L
16	0 511 645 607	230	500	3,000	3.6	79	146.7	127.7

Dimensions in mm

N-Motor

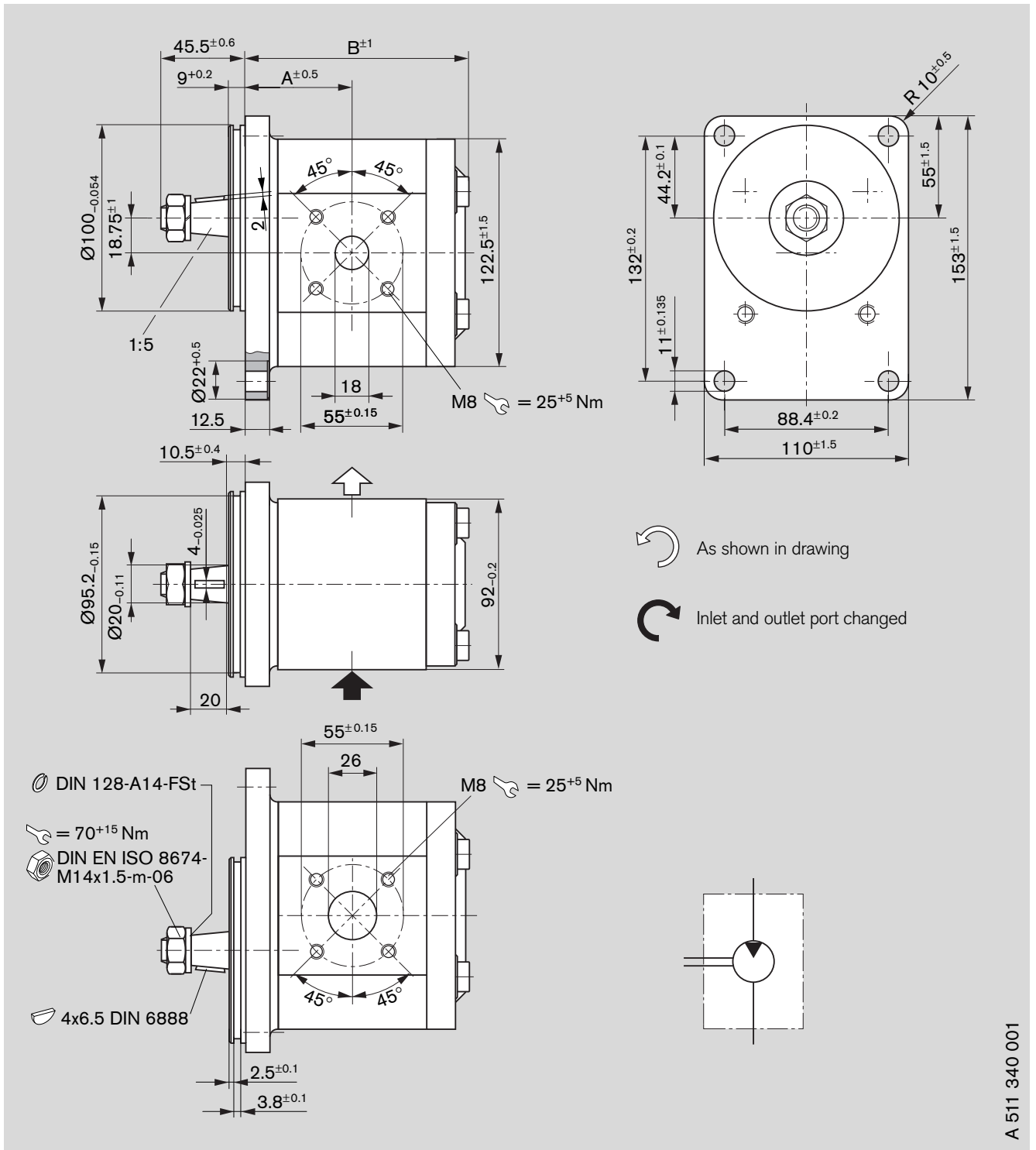

A 511 340 001

Ordering code

AZMN - 11 - C B 20 M B

Displacement [cm ³ /rev]	Ordering-No.		Max. operating pressure [bar]	Min. rotation speed [min ⁻¹]	Max. rotation speed [min ⁻¹]	kg	Dimension [mm]	
	L	R					A	B
25	0 511 725 307	-	210	500	3,000	6.3	55.0	116.1
28	0 511 725 309	0 511 725 019	200	500	3,000	6.3	56.6	119.1

Dimensions in mm

N-Motor

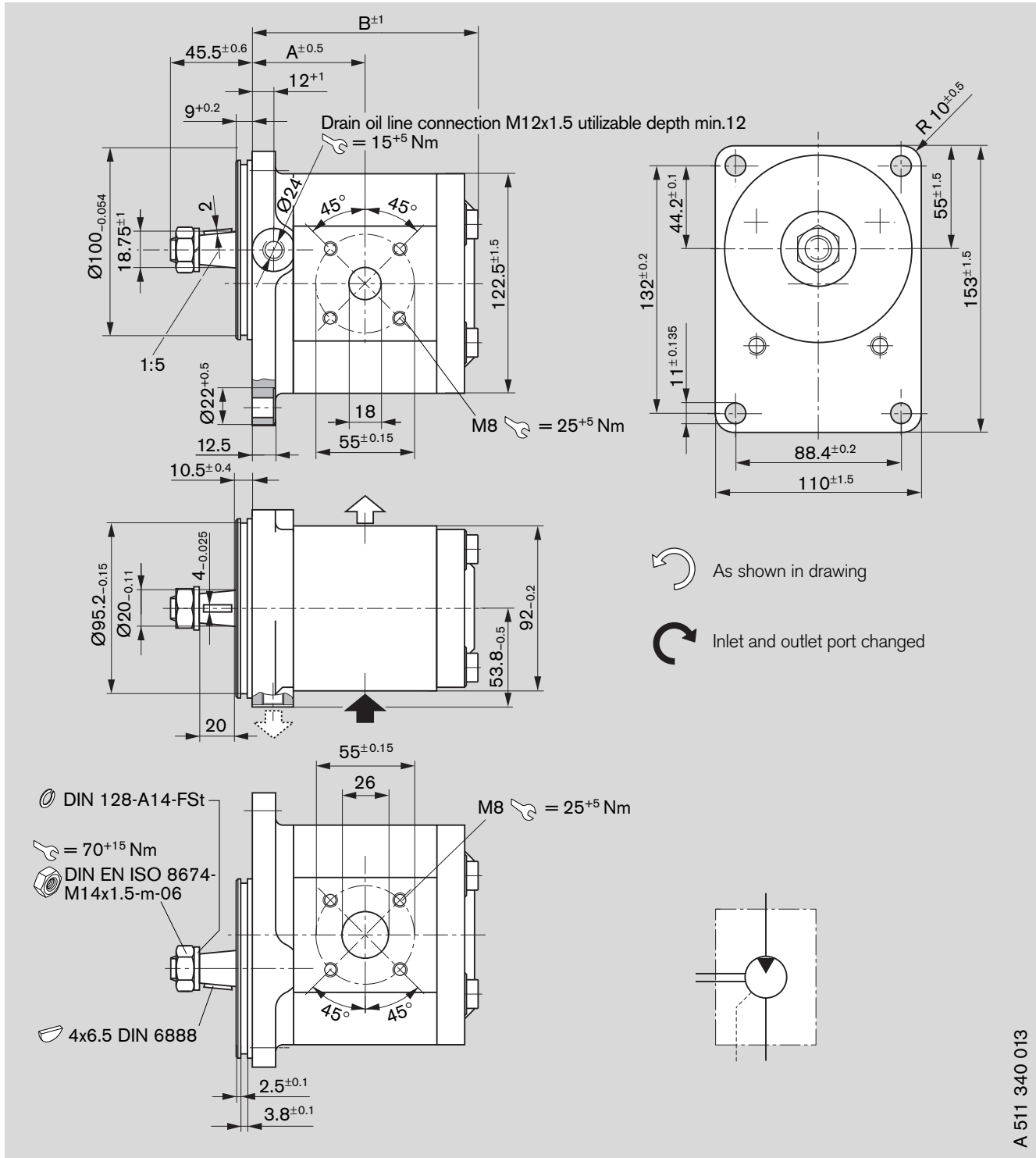

A 511 340 013

Ordering code
AZMN - 11 - C B 20 P B - S0097

Displacement [cm ³ /rev]	Ordering-No.		Max. operating pressure [bar]	Min. rotation speed [min ⁻¹]	Max. rotation speed [min ⁻¹]	kg	Dimension [mm]	
	L	R					A	B
25	-	0 511 725 024	210		3,000	10.3	60.5	120.8
28	0 511 725 312	-	210		2,800	6.1	62.0	123.8

Dimensions in mm

G-Motor

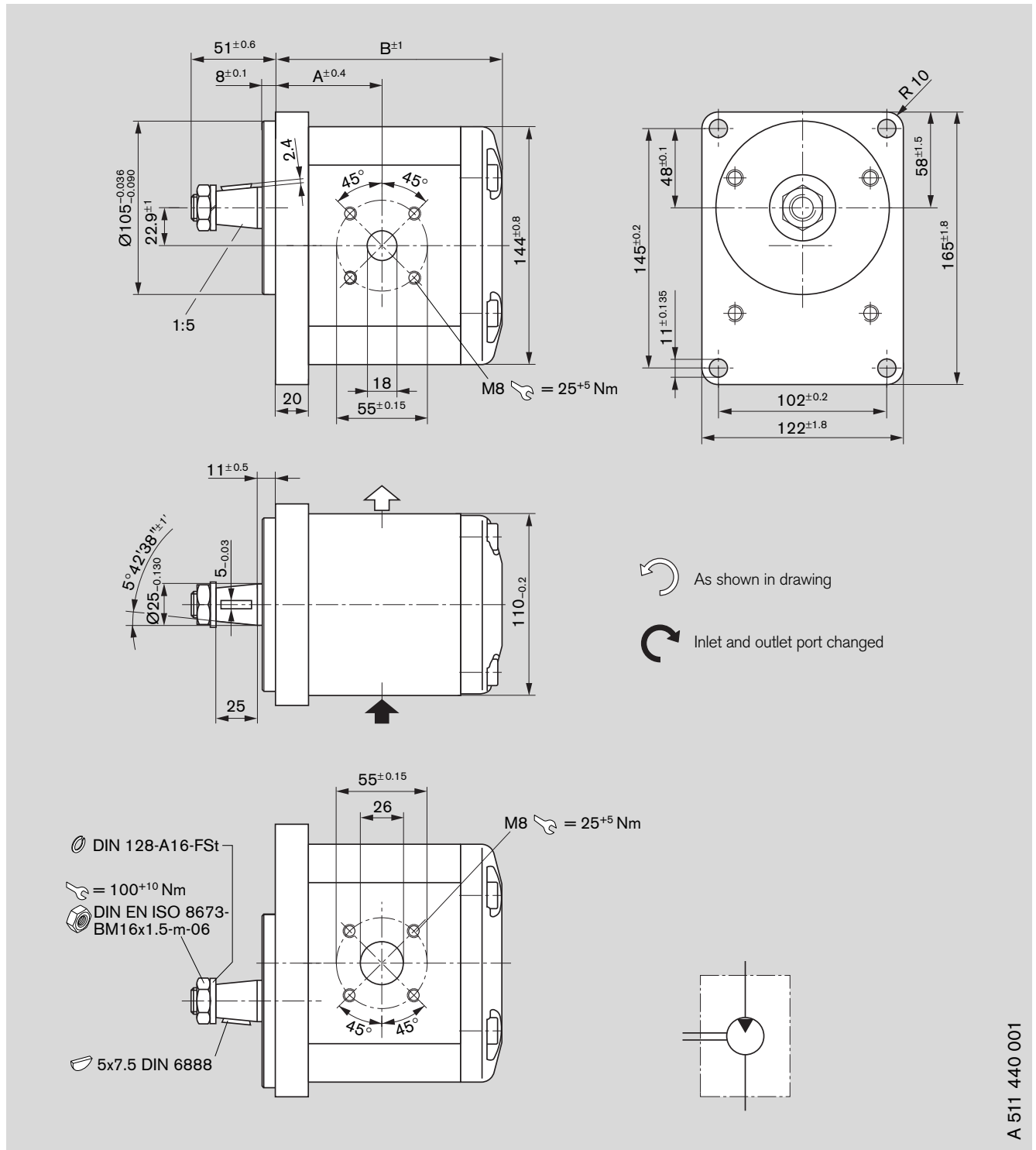

A 511 440 001

Ordering code

AZMG - 11 - C B 20 M B

Displacement [cm ³ /rev]	Ordering-No.		Max. operating pressure [bar]	Min. rotation speed [min ⁻¹]	Max. rotation speed [min ⁻¹]	kg	Dimension [mm]	
	\curvearrowleft L	\curvearrowright R					A	B
22.5	0 511 725 300	0 511 725 001	180	500	3,000	9.1	61.0	128.7
32	0 511 725 301	0 511 725 002	180	500	2,800	9.6	64.5	137.2
45	0 511 725 302	0 511 725 003	180	500	2,600	10.1	69.5	149.2

Dimensions in mm

G-Motor

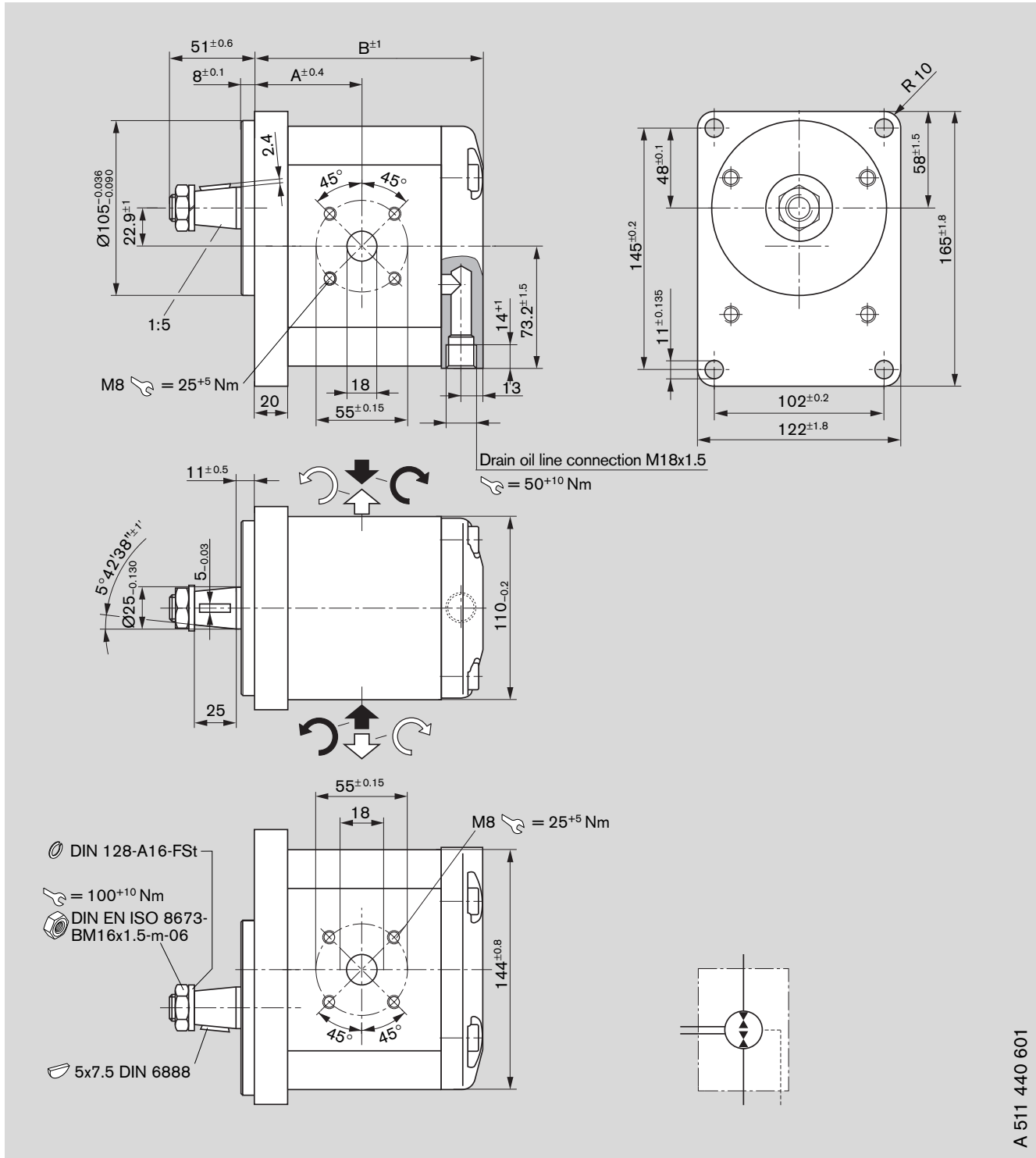

A 511 440 601

Ordering code
 AZMG - 11 - U C B 20 K X* - S0077
 AZMG - 11 - U C B 20 M X - S0077

Displacement [cm ³ /rev]	Ordering-No. Universal	Max. operating pressure [bar]	Min. rotation speed [min ⁻¹]	Max. rotation speed [min ⁻¹]	kg	Dimension [mm]	
						A	B
22.5	0 511 725 600	210	500	3,000	9.0	61.0	128.7
28	0 511 726 603	210	500	3,000	9.2	63.0	133.7
32	0 511 726 604*	210	500	2,800	9.4	64.5	137.2

Dimensions in mm

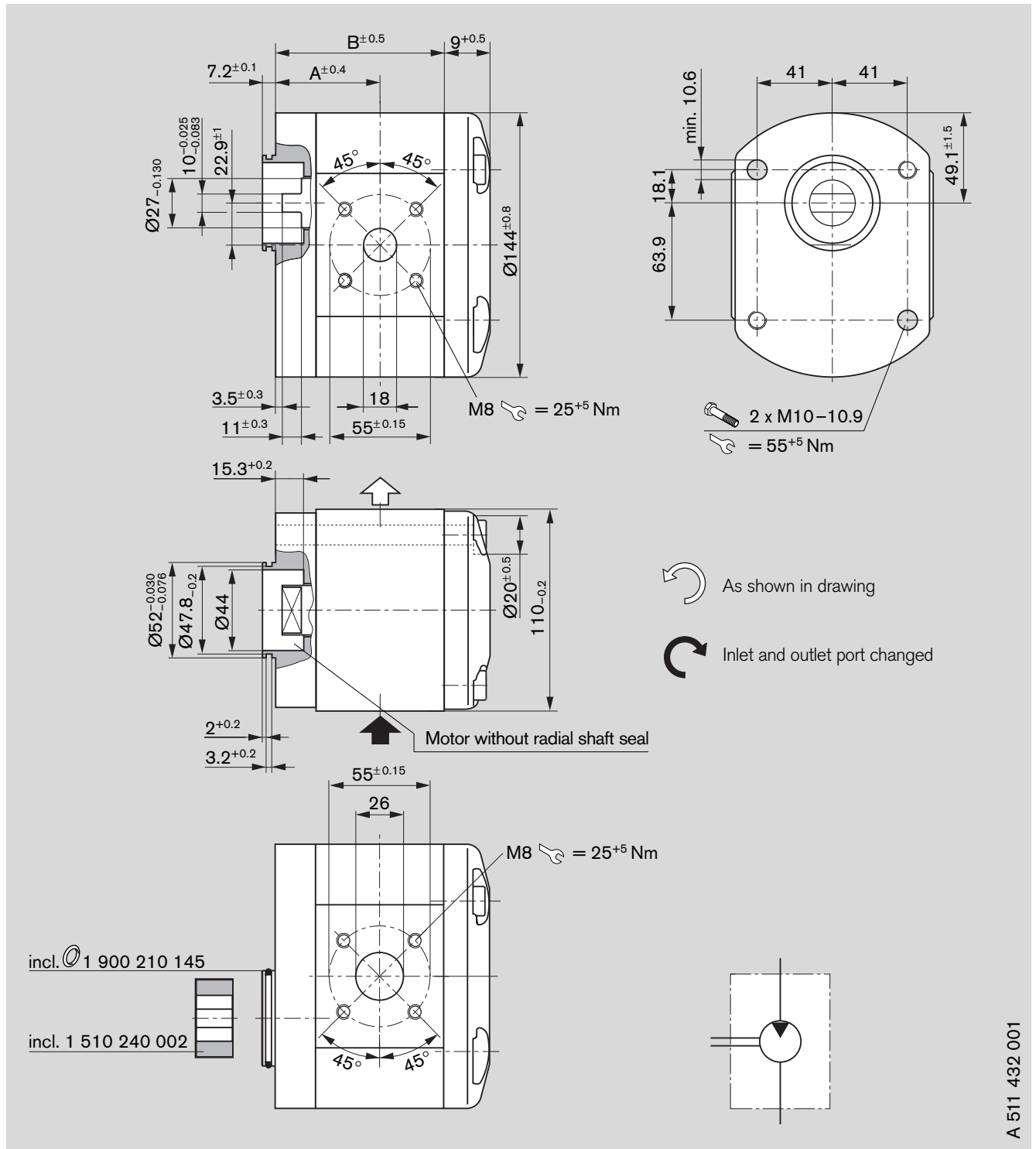

G-Motor



A 511 432 001

Ordering code

AZMG - 11 - N M 20 M B

Displacement [cm ³ /rev]	Ordering-No.		Max. operating pressure [bar]	Min. rotation speed [min ⁻¹]	Max. rotation speed [min ⁻¹]	kg	Dimension [mm]	
	 L	 R					A	B
45		0 511 715 002	210	500	2,600	8.4	70.5	151.2

Notes

Filter recommendation

The major share of premature failures in external gear motors is caused by contaminated pressure fluid.

As a warranty cannot be issued for dirt-specific wear, we recommend filtration compliant with cleanliness level 20/18/15 ISO 4406, which reduces the degree of contamination to a permissible dimension in terms of the size and concentration of dirt particles:

Operating pressure [bar]	>160	<160
Contamination class NAS 1638	9	10
Contamination class ISO 4406	18/15	19/16
To be reached with $\beta_x = 75$	20	25

We recommend that a full-flow filter always be used. Basic contamination of the pressure fluid used may not exceed class 20/18/15 according to ISO 4406. Experience has shown that new fluid quite often lies above this value. In such instances a filling device with special filter should be used.

General

- The motors supplied by us have been checked for function and performance. No modifications of any kind may be made to the pumps; any such changes will render the warranty null and void!
- Motor may only be operated in compliance with permitted data (see pages 14 – 18).

Project planning notes

Comprehensive notes and suggestions are available in Hydraulics Trainer, Volume 3 RE 00 281, "Project planning notes and design of hydraulic systems". Where external gear motors are used we recommend that the following note be adhered to.

Technical data

All stated technical data is dependent on production tolerances and is valid for specific marginal conditions.

Note that, as a consequence, scattering is possible, and at certain marginal conditions (e.g. viscosity) **the technical data may change.**

Characteristics

When designing the external gear motor, note the maximum possible service data based on the characteristics displayed on pages 10 to 14.

Additional information on the proper handling of hydraulic products from Bosch Rexroth is available in our document: "General product information for hydraulic products" RE 07 008.

Leakage oil line

A leakage oil line must be connected directly to the tank in reversible motors or motors stressed by run-back. Observe sufficient dimensions.

Contained in delivery

The components with characteristics as described under device measurements and ordering code, pages 19 – 39, are contained in delivery.

You can find further information in our publication: "General Operating Instructions for External Gear Units" RE 07 012-B1.